



APPLICATION NOTE #:	AN_VFD_GEN022
EFFECTIVE DATE:	06/08/05
SUPERSEDES DATE:	-
ORIGINATOR:	Mike Branda
NO. OF PAGES:	4

## CV10 and GP10 External Trip Interface and Input and Output Contactors

On occasion a user may desire to interface an external contact with an AFD to initiate a motor stop. In some cases this may take the form of a normal controlled shutdown where the motor ramps to a stop based on the AFD setup of ramp time, and dc injection braking level and time. In other cases a motor coast to stop might be desired. Although none of these require the use of an isolation contactor, there may be a requirement for a mechanical isolation of the motor from the AFD or the AFD from the utility source, or that the AFD be locked out from restarting without first being reset. The chosen location for the contactor is based on the user's preferences, but the output contactor is the most frequently recommended and applied.

All of these stop functions can be supported but the user needs to be aware of the ramifications of each and the proper implementation.

Since the normal start/stop interface is well covered in the AFD instruction literature, this note is limited to the use of an external trip contact and an input or output contactor for isolation and the appropriate method to trip the AFD to prevent unintended restart through the normal operator control.

### Input Contactor

#### Advantages

- Positive removal of power from AFD and motor.

#### Disadvantages

- Should not be used to start and stop the drive, especially for high on/off cycle operation as it can lead to charging circuit failures.
- Will drop out on power failure limiting AFD's ability to use load inertia's stored energy as buffer and to restart when power reapplied – if this is application requirement – without complex control circuitry.
- Subject to mechanical wear and tear maintenance.

### Output Contactor

#### Advantages

- Positive removal of power from motor.

#### Disadvantages

- Requires interlocking so drive does not start before contactor closes for normal start.
- Requires interlocking so drive turns off before contactor opens for normal stop.
- Will drop out on power failure limiting AFD's ability to use load inertia's stored energy as buffer and to restart when power reapplied – if this is application requirement – without complex control circuitry.
- Requires drive output to be stopped (tripped) before contactor opened for an emergency type stop.
- Subject to mechanical wear and tear maintenance.

When a trip is required that includes a manual reset, whether no contactor, an input contactor, or an output contactor is used, the external control requiring the trip must be interfaced with the AFD and the parameters selected to cause the appropriate shutdown.

For a CV10, the base block function is used to shut down the drive. One of the terminal inputs, S1 to S5, would be connected to a **NO** contact from the external control. Based on the input terminal selected one of parameters 5-00 to 5-06 would be set for **0008**, Base Block, to stop the CV10. If this contact is opened and the run permissive remains, the CV10 will restart. If this is not desirable, two other possibilities exist. The first is to use open the run contact simultaneously to closing the base block contact. If the base block contact is opened after

the CV10 has stopped, there will be no restart since the run contact is open. The second choice is to initiate an Emergency Stop function. This can be done by programming another of the inputs to **0007**, Emergency Stop. Emergency stop will cause the motor to be ramped down as a normal stop by using the deceleration 2 time set by parameter 3-07. The emergency stop input would be wired to the same contact as the base block input. To reset an emergency stop, press the Run/Stop button on the keypad to start the CV10 or if an external run command is being used, open and close the external contact to start the CV10. Note that if an output contactor is used, it must not be opened until the contact for Base Block and/or the emergency stop is closed. Before these contacts are closed to run the CV10 the output contactor must be closed. Refer to the CV10 manual for the Base Block function description.

### Wiring Diagram CV10 Series Drive

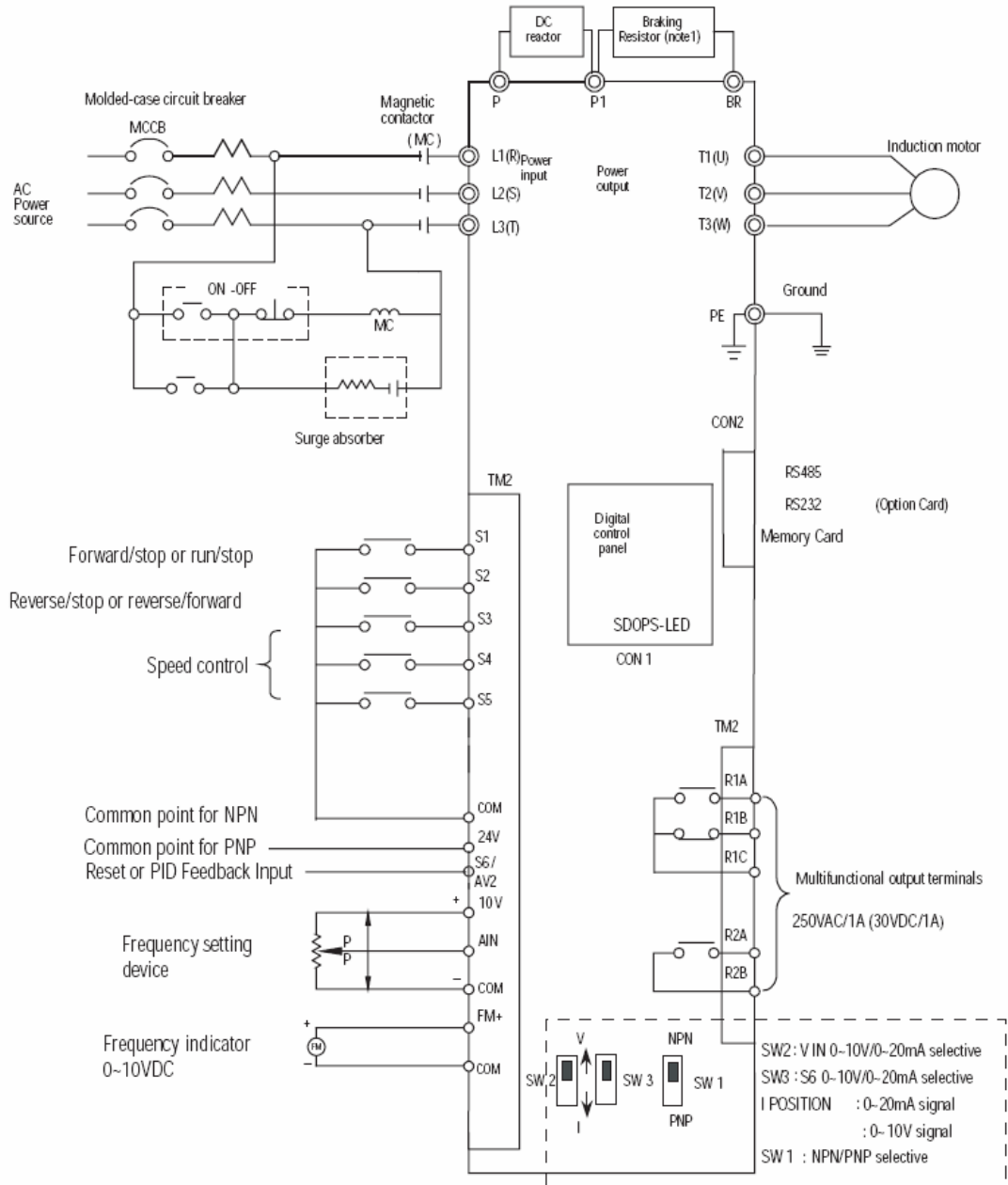

For a GP10, the external trip function is used to shut down the drive. A **NC** contact is wired to one of the digital input terminals, X1 to X9. Opening the contact will trip the AFD. Depending upon the terminal selected, parameter E01 to E09 would be set to **9**, External Alarm. To reset the trip, a **NO** contact would be wired to one of the other input digital input terminals whose corresponding parameter would be set to **8**, RST. Alternatively the trip may be reset by the RESET button on the GP10 keypad. Note that if an output contactor is used, it must not be opened until the contact for the External Alarm is opened.

### Wiring Diagram GP10 Series Drive

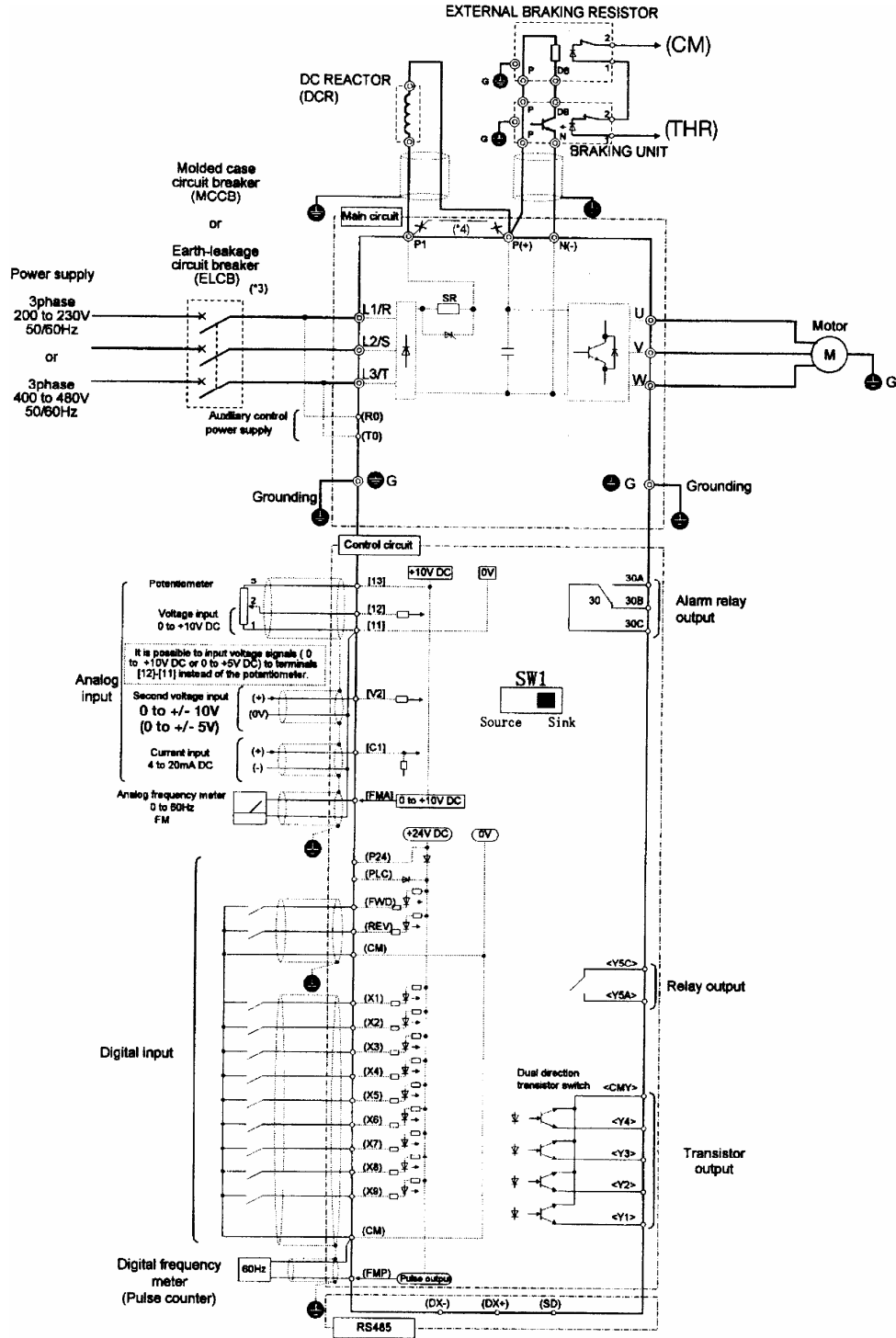

Input and Output Contactor Ratings

Most AFDs utilize AC3 rated IEC contactors for their space saving designs. The following AC3 ratings can be used on the input or output of Saftronics CV10 and GP10 drives.

Drive Voltage	Drive Hp	Contactors Rating
230	0.5	3 Hp, 10 A
	1	3 Hp, 10 A
	2	3 Hp, 10 A
	3	3 Hp, 10 A
	4	5 Hp, 17.5 A
	7.5	7.5 Hp, 22 A
	20	10 Hp, 32 A
	15	15 Hp, 48 A
	20	20 Hp, 62 A
	25	25 Hp, 68 A
	30	30 Hp, 80 A
	40	40 Hp, 96 A
	50	50 Hp, 140 A
	60	60 Hp, 156 A
	75	75 Hp, 192 A
	100	100 Hp, 302 A
125	150 Hp, 398 A	
150	150 Hp, 398 A	
460	0.5	5 Hp, 10 A
	1	5 Hp, 10 A
	2	5 Hp, 10 A
	3	5 Hp, 10 A
	5	5 Hp, 10 A
	7.5	7.5 Hp, 13.8 A
	10	10 Hp, 17.5 A
	15	15 Hp, 22 A
	20	20 Hp, 32 A
	25	25 Hp, 34 A
	30	30 Hp, 48 A
	40	40 Hp, 62 A
	50	50 Hp, 68 A
	60	60 Hp, 80 A
	75	75 Hp, 96 A
	100	100 Hp, 140 A
	125	125 Hp, 156 A
	150	150 Hp, 192 A
	200	250 Hp, 302 A
	250	250 Hp, 302 A
300	300 Hp, 398 A	
350	400 Hp, 480 A	
400	400 Hp, 480 A	
450	500 Hp, 602 A	
500	500 Hp, 602 A	