

PID Mode For the 10 Series Drives

The following tech note will support the setup of PID operation in the 10 series drives. A simple flowchart to walk through the programming of the PID and an explanation of the adjustment of the variables of the PID loop. Also, by providing a step by step procedure in programming of the drives for several types of control logic. The tech note shows in detail for two examples or cases of PID logic and the associated programming and wiring of the system.

The following flowchart provides a step by step procedure on the basic set up of PID operation for the 10 Series Drives.

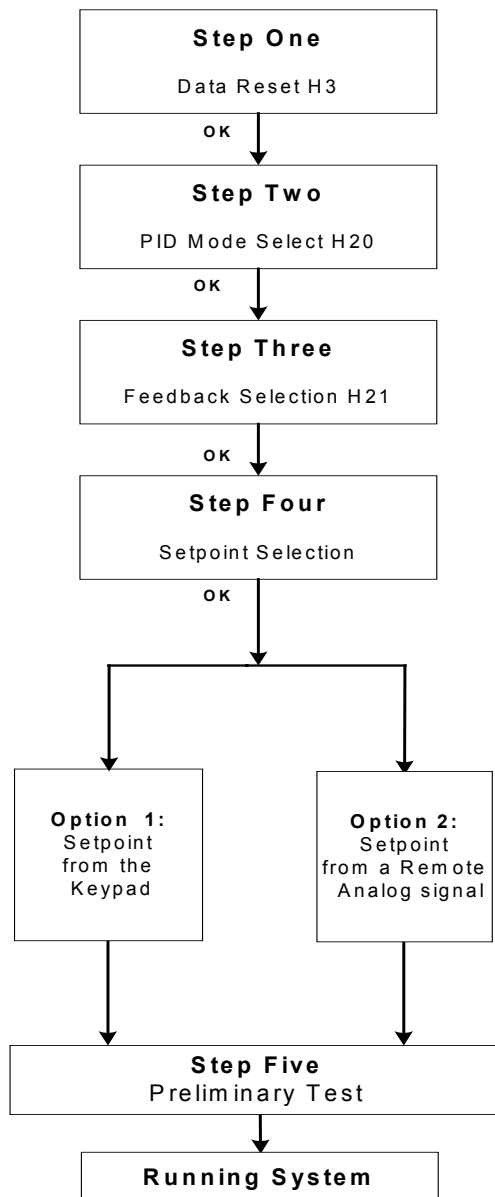

Terms:

Setpoint = the desired level or pressure in the system, this signal is input into the drive so the drive will compensate the output, so the feedback value will match the setpoint value.

Feedback = the variable from the system that is brought back to the drive as a corrective signal.

Step One:
Data Reset: H3 = 1 Hold Stop Button and Up arrow simultaneous to change value.

Set the drive to default settings (H3 Data Reset) before starting the PID startup.

See the instruction manual on page 5.29 for PC10, and page 5.34 for VG/GP10, for further details.

OK

Step Two:

PID Mode Selection: H20
0 = PID Disable
1 = Normal operation
 If the feedback signal is greater than the set point, the output of the inverter will decrease the speed of the motor.
Most application require H20 set to 1

2 = Inverse operation
 If the feedback signal is greater than the set point, the output of the inverter will increase the speed of the motor.

Note: See the Instruction manual on page 5-32 for PC10. Page 5-37 for VG/GP10, for further details.

OK

Step Three:
 Select the type feedback that is used in the system.

Feedback Selection: H21

0 = Term. 12	0 to 10Vdc
1 = Term. C1	4 to 20mA
2 = Term. 12	10 to 0 Vdc
3 = Term. C1	20 to 4 ma

Typically the feedback is a current signal and the factory setting is (1)

Note: Feedback and Setpoint signal must be of a different type signal. Example Current signal for feedback and Voltage for setpoint signal.

OK

Step Four
Setpoint Selection:
 Choose one of two options

Setpoint from the Keypad

Setpoint from a Remote Analog signal

To Page 3

Current Feedback Signal
 Connect (+) signal to Term.C1
 Connect (-) signal to Term.11
H21= 1 (4-20mA)
H21= 3 (20 - 4mA)

Voltage Feedback Signal
 Connect (+) Vdc to Term.12
 Connect (-) Vdc and Term.11
H21= 0 (0 -10Vdc)
H21= 2 (10 - 0Vdc)

OK

NO

YES

Feedback
 Is it a current signal?

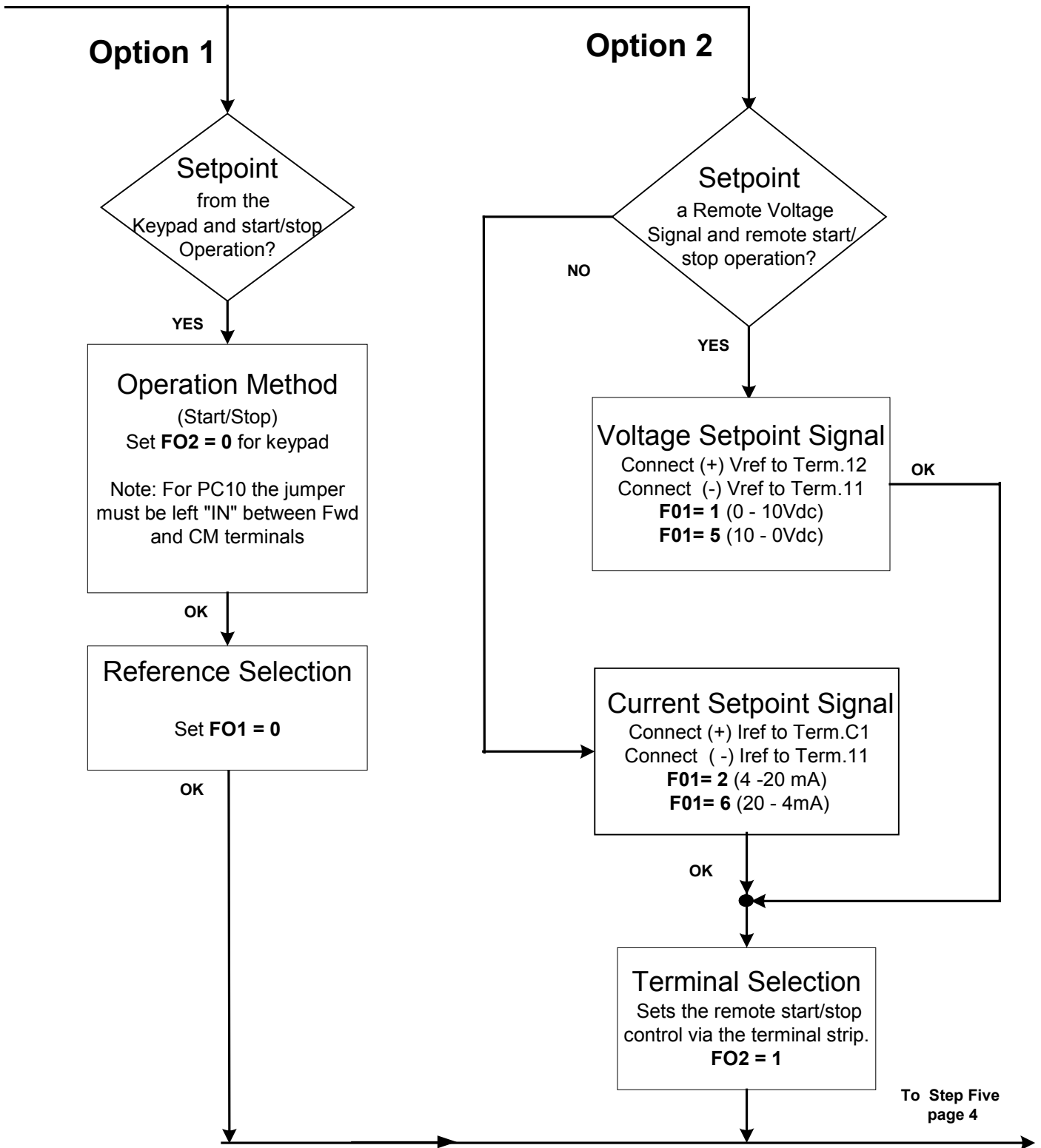

A setpoint range must be set into the drive

Step Five:
Preliminary Test

Keypad Display

GP/VG10 keypad display has the capability to view the Feedback and Setpoint level. By setting **E43 = 10, 11 or 12, and E44 = 1.**

PC10 will display the feedback level when running and setpoint when stopped if the setpoint is from a remote signal. If setpoint from the keypad you will need to press the UP or DOWN key to display setpoint. E40 will scale the feedback value on the keypad. If the keypad is the setpoint, it defaults to a range of 0 to 100%.

Range

E40 and **E41** are required to be set, for the range of the system. In the previous test the **E40** was set to 60 to represent the maximum frequency setpoint. To have desired setpoint range from the feedback signal (4 -20ma) will represents 0 to 100PSI in the system. So then program E40 = 100 and E41 = 0

Note: See the instruction manual on page 5-26 for GP/VG10. Page 5-23 for PC10 for further details on setting the setpoint range in the drive.

H22 P- gain

Increasing the gain, will speed up the response. Excessive gain causes instability, decrease in gain will delay or slow response.
Initial Setting =1.0

H23 Integral time

Setting this parameters is application depended. The dynamic response of the system will determine the time constant. A shorter integration time speeds up response, but an integration time that is too short causes instability.
Initial Setting should be 1.0sec

TEST

Step 1: Start command

Terminal operation apply a start command to the Fwd or Rev digital input terminal.
Keypad mode apply a start command by using the Fwd or Rev key on Keypad.

Step 2: Setpoint Signal

Adjust the setpoint level to display on the keypad. Set to 50 % of maximum freq. (30 hz)
Note: Feedback signal should be disconnected or manually adjusted to zero.

Step 3: Feedback Signal

Then manually adjust your feedback level to 50% (Ifdbk = 12 mA at 50 %, Vfdbk = 5Vdc). If you can not manually adjust the level wait to the process allows the signal to come up to the 50% level. Then the output freq. of the drive will go to zero speed.

Note: To view reference signal press FUNC/DATA key until the LCD displays the PID setpoint for the VG/GP10 and the PC10 will display the setpoint once the UP or DOWN arrows are pressed.

OK

H24 Differential time

Setting this parameter is application depended. The dynamic response of the system will determine the time constant. Excessive differentiation time could cause instability. Shorting the differentiation time reduces attenuation at the occurrence of deviation.

OK

H25 Fdbk Filter

This filters the feedback signal input from terminals 12 or C1. This filter stabilizes operation of the PID control system. A set value too large, however, deteriorates response.

OK

Running System

Typical PID Connection Diagram (Option 2)

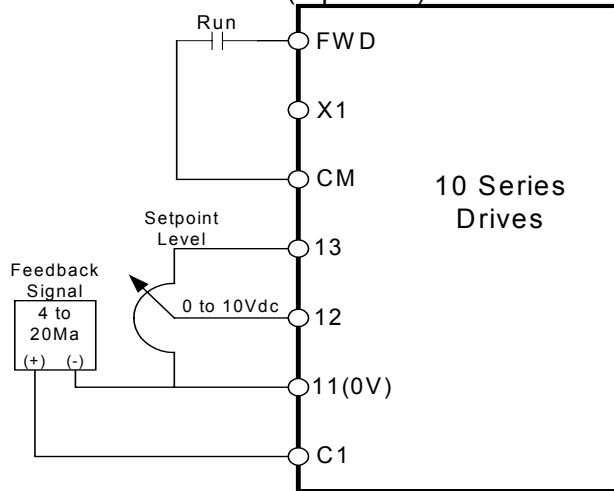

Case 1:

Description: PID mode is when the drive is operating the PID loop and Manual mode has the frequency control from the keypad with no PID loop.

Function: A run command is given and the set-point is entered via the keypad, the drive will operate in PID mode. Then when PID/Manual switch is activated, PID is cancelled and the drive will now following the keypad as the frequency reference or speed control.

Programming:

F01 = 0	Frequency Reference or Set-point
F02 = 1	Start/ Stop from terminal strip
F11 = FLA of Motor	Sets the overload protection for the motor
E01 = 16 for PC10	Terminal X1 PID disable for PC10
E01 = 20 for GP/VG10	Terminal X1 PID disable for GP/VG10
E40 = 100	Scales set-point to 0 to 100%
H20 = 1	Turns on PID mode (normal operation)

PID Mode with Setpoint from the Keypad and Manual Mode with PID disabled and Reference from the Keypad

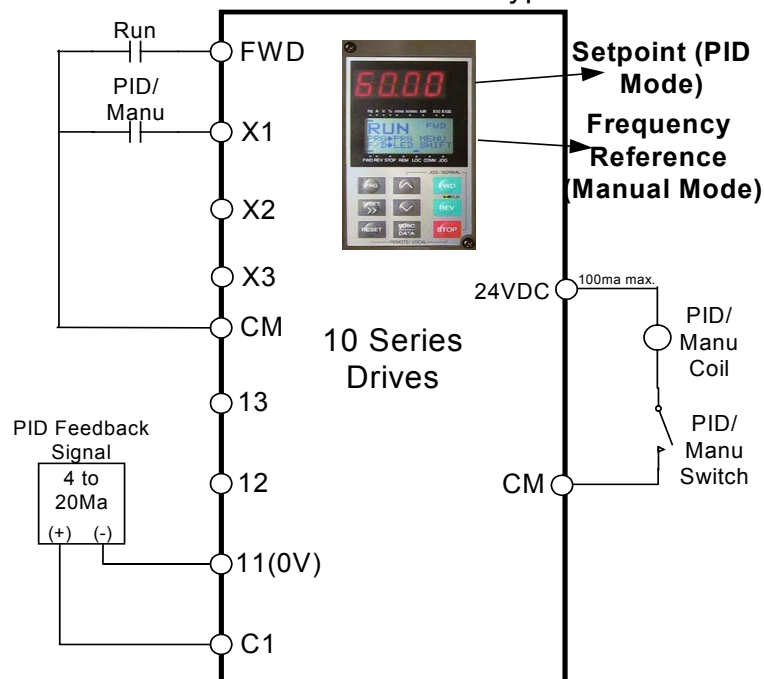

Case 2

Description: A system that requires PID mode and a manual speed mode. The manual speed mode, the operator uses a speed potentiometer to control the speed of the drive. Then in PID mode the keypad now controls the set-point level of the PID loop. A contact will switch from PID to manual mode, the switch will have to be performed at zero speed.

Function: Run command is made on the terminals and the set-point is controlled via the keypad when the drive operates in PID mode. Then when PID/Manual switch is activated, PID mode is cancelled and the drive will now following the speed pot. as the frequency reference or speed control and the start/stop is controlled through the terminals. When switching modes the drive is required to be stopped. (no start or run command)

Note: *PID/Manual switch has to be made before the run command is applied. If run command is made at the same time or before the PID/Manu switch the drive will not change modes of operation.*

Programming:

- F01 = 0 Set-point is via Keypad (0 to 100%)
- F02 = 1 Start/ Stop from terminal strip
- F11 = FLA of Motor Sets the overload protection for the motor
- E01 = 9 for PC10 Terminal X1 Switch from freq. setting 1 to 2 for PC10
- E01 = 11 for GP/VG10 Terminal X1 Switch from freq. setting 1 to 2 for GP/VG10
- E02 = 10 for PC10 Term. X2 Switch from Motor1 to Motor2 (disables PID mode)
- E02 = 12 for GP/VG10 Term. X2 Switch from Motor1 to Motor2 (disables PID mode)
- E40 = 100 Scales set-point to 0 to 100%
- H20 = 1 Turns on PID mode (normal operation)
- C30 = 1 Speed control via the speed pot. (0 to 60Hz.)

PID Mode with Setpoint from the Keypad and Manual Mode with PID disabled and Reference from the Speed pot.

