

# V10

## Compact Vector AC Drive



## Quick-Start Guide REV 1.1

PART NUMBER 027-2177  
SEPTEMBER 2004





# ***Table of Contents***

Step 1 – Before Starting the Drive.....	2
Wiring Diagram.....	3
Description of Main Circuit Terminals .....	4
Description of Control Circuit Terminals.....	4
Keypad and Display Description .....	5
Step 2 – Apply Power to the Drive.....	5
Parameter Groups .....	6
To Change Parameter Data.....	6
Step 3 - Enter Setup Data .....	7
Step 4 - Check Motor Rotation.....	8
Step 5 - Check Full Speed at 50Hz/60Hz.....	9
Step 6 – Other Operations.....	9

# Quick Start Guide

This guide is to assist in installing and running the drive to verify that the drive and motor are working properly. Initially, the motor will be started and stopped using the Run/Stop Key on the digital operator.



Using  and  keys will set the Speed Reference. Operation from remote start/stop inputs or contact closures is described later.

## Step 1 Before Starting the Drive

Please review Preface and Safety Precautions (page 13 through 16) of the CV10 Instruction Manual. Verify drive was installed in accordance with the procedures as described in CV10 Ambient Environment and Installation on pages 18 through 32. If you feel this was abnormal, do not start the drive until qualified personnel have corrected the situation. (Failure to do so could result in serious injury.)

**Check Drive and motor nameplates to determine that they have the same HP and voltage ratings. (Ensure that full load motor amps do not exceed that of the Drive.)**

- **Record the Following Information from the motor nameplate:**

- Motor Rated Voltage
- Motor Rated Speed (RPM)
- Motor Rated Frequency (Hz)
- Motor Rated Full Load Current (Amps)
- Motor Rated Horsepower

- **Remove the terminal cover to expose the motor and power terminals.**

- Connect AC power to L1, L2, and L3 terminals.**
- Connect AC Motor leads to T1 (U), T2 (V), and T3 (W).**

**Do not connect AC power supply to T1 (U), T2 (V), and T3 (W) terminals of the drive or serious damage to the drive will result.**

---

## Wiring Diagram CV10 Series Drive

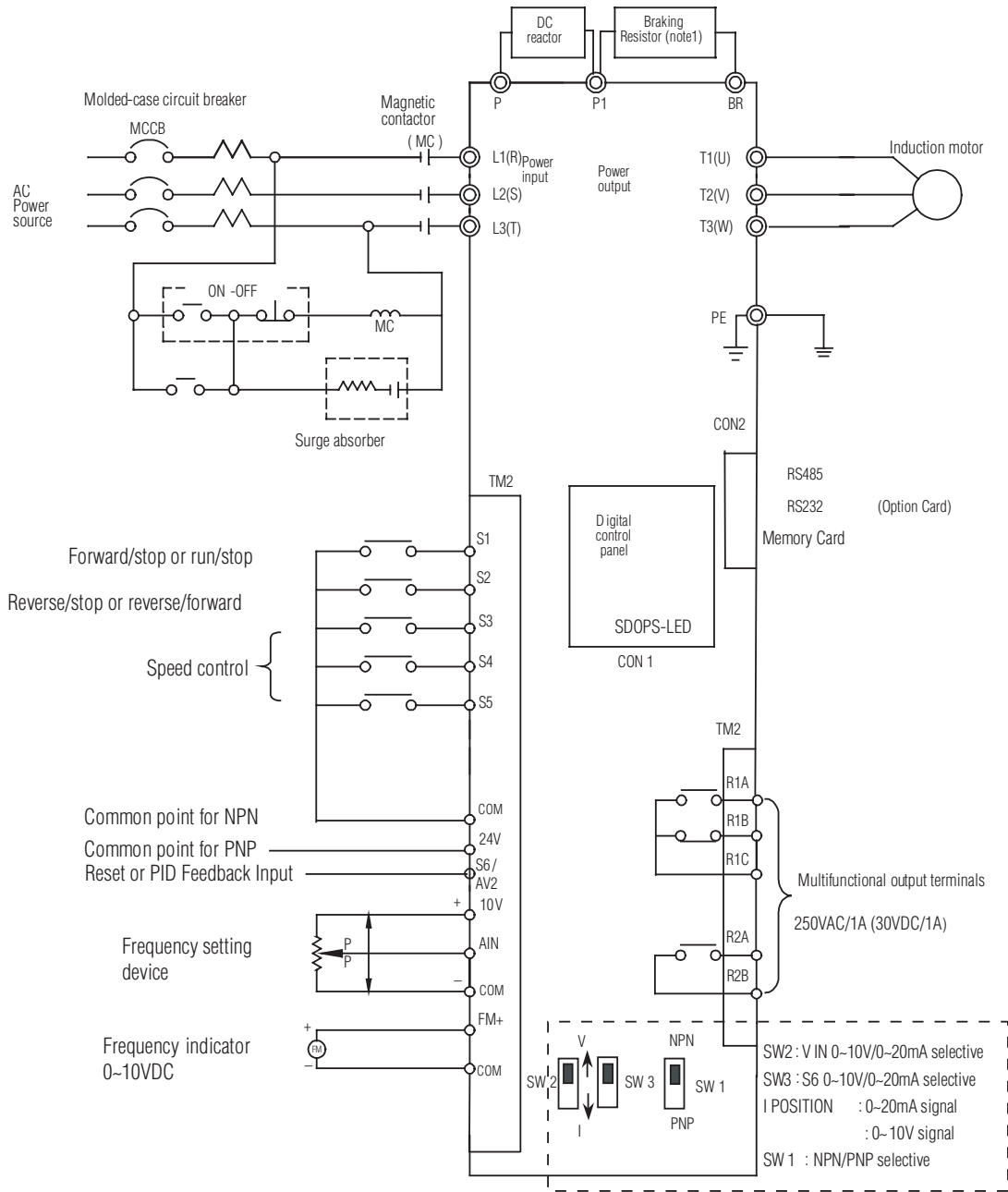

### Descriptions of CV10 Main Circuit Terminals

Terminal	Description
L1 ( L )	Main power input: Single-phase: L/N Three-phase: L1/L2/L3
L2	
L3 ( N )	
P1	Braking resistor or connecting terminal: Used in cases where the drive frequently trips due to large load inertia or short deceleration time (refer to specifications of braking resistor)
BR	
P1 and P	DC reactor connecting terminals
T1	Drive output
T2	
T3	

### Descriptions of CV10 Control Circuit Terminals

Terminal	Description		
R2A	Multifunctional terminals – Normally open	Contact rated capacity: (250VAC/1A or 30VDC/1A) Contact using description: (refer to 8-02, 8-03)	
R2B			
R1C			Common contact
R1B			Normally close contact
R1A	Normally open contact		
10V	Speed Potentiometer (VR) power source terminal (referenced to COM)		
AIN	Analog frequency signal input terminal (refer to 5-06 description)		
24V	Common contact for S1~S5 in PNP (source) input. (refer to CV10 wiring diagram) of SW1 when PNP input is used.		
COM	Common contact for S1~S5 in NPN (sink) input. (refer to CV10 wiring diagram) of SW1 when NPN input is used.		
FM+	The positive analog output for multifunction (refer to 8-00 description), the signal for output terminal is 0-10VDC		
S1	Multifunction input terminals(refer to 5-00 ~ 5-04 description)		
S2			
S3			
S4			
S5			
S6/AV2	PID input terminal (refer to 5-05 description)		

## Keypad and Display Description



1. **Hz/RPM LED** Indicates Speed Reference (Frequency) when stopped and Output Frequency when running. To display RPM or Engineering units it must be selected in the program. See parameters 4-04 and 4-05 page 61 of the CV10 Instruction Manual.
2. **VOLTS LED** Indicates Output Voltage when running and also DC Bus Voltage.
3. **AMPS LED** Indicates Output Current.
4. **FUNC** Indicates Drive is in Program Mode.
5. **SEQ** Remote Start/Stop when lit, Local Start/Stop (Run/Stop Key) when off.
6. **FRQ LED** Remote Speed Reference when lit, Local Speed Ref. when off.
7. **FWD LED** Indicates Forward Direction when lit (Flashes if stopped, Stays Lit while operating).
8. **REV LED** Indicates Reverse Direction when lit (Flashes if stopped, Stays Lit while operating).
9. **DSP/FUNC** Access program mode. Scroll thru monitoring functions.
10. **LOCAL/REMOTE** Switches between Local (Keypad Operation) and Remote Control (Terminal Control).
11. **LCD keypad** does not have FUNC, Hz/RPM, VOLT, and AMP LEDs.
12. **RESET** Moves digit to be changed from right to left. Resets drive fault.
13. **READ/ENTER** Saves Edited Parameter Data into Memory.
14. **UP/DOWN** Changes speed ref up or down when in local. Also Parameter values.

### Step 2 Apply Power to the Drive









Apply AC power to the drive and observe the keypad. The four digit 7-segment display should read the AC Input Voltage for 3~5 seconds and then it will display flashing 05.00 Speed Reference (Hz/RPM LED lit). The FWD LED should be flashing all the time. If this condition is not observed, then the drive parameters need to be reset to Factory Settings. Parameter 15-6 must be set accordingly (see page 81 of the CV10 instruction manual). Also see "To Change Parameter Data".





## CV10 PARAMETER GROUPS

Each parameter group branches off into individual parameters. See pages 41 through 50 for more detailed information about each parameter number.

Parameter Group No.	Description
0-	Drive Operation Mode
1-	Start/Stop and Frequency Control Modes
2-	Manual/Automatic Restart Modes
3-	Operating Parameters
4-	Digital Display Operation Mode
5-	Multifunction Input Terminals (MFIT)
6-	Jog, and Preset (MFIT) Speed Setting on Keypad
7-	Analog Input Signal Operation
8-	Multifunction Output Relays and Output Signal Operation
9-	Drive and Load Protection Modes
10-	Volts/Hz Pattern Operation Mode
11-	PID Operation Mode
12-	PID "Limits" and "Out of Range" Mode
13-	Communication Mode
14-	Motor Auto-Tuning Parameters
15-	Drive Status and Function Reset

### To change Parameter Data:

- 1) Press the  key until the display reads "X - YY" (X parameter group, Y parameter number). The initial value will be "0-00".
- 2) Press the  or  keys to change the parameter number. The first digit to be changed will always be the farthest to the right "X-YY" and it will be flashing.
- 3) Press the  key to move to the next flashing digit to be changed "X-YY". Edit by using the  or  keys.
- 4) Press the  key to edit the parameter value.
- 5) Press the  or  keys to change the parameter value. The digit to be edited will be flashing.

- 6) Press the  key to move to the next digit to be changed with the  or  keys.
- 7) Press the  key to save the edited parameter value to memory. Display will read "END" indicating it saved the information then the parameter edited will be displayed in the keypad.

### Step 3 Enter Setup Data

Use the flowchart below as a guide when entering setup data. There are two different procedures for entering setup data, one for the Vector Control modes and the other for the Volts/Hz mode of operation. Use the motor nameplate data recorded earlier to enter setup data parameter values.

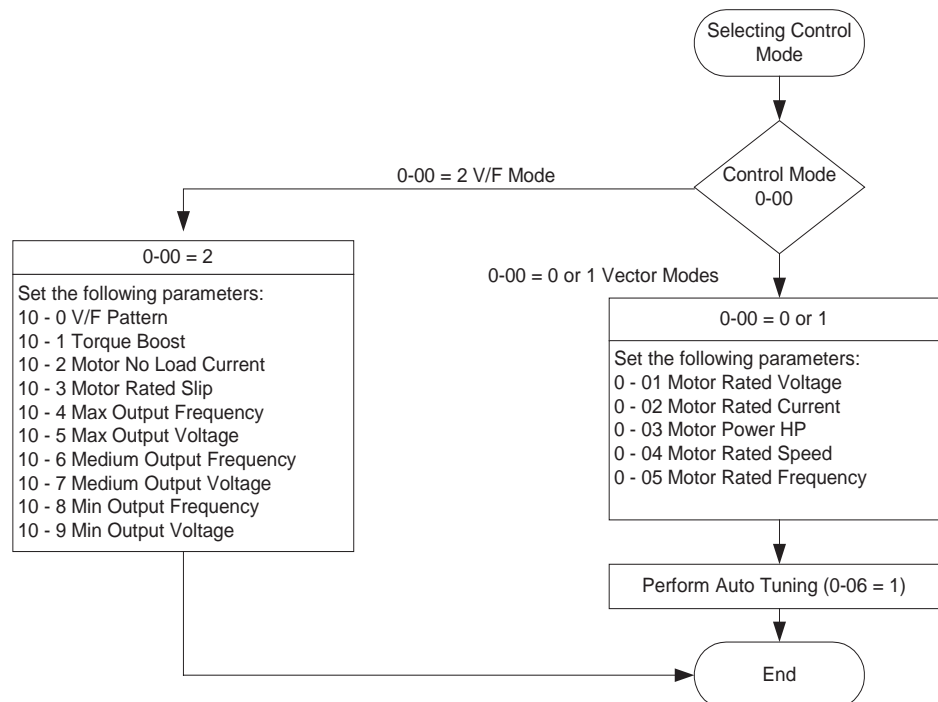

• **Selecting Drive Operating Mode:**

- Vector (General Purpose):** Use for General Purpose applications when a single motor is connected to the drive.
- Vector (Variable Torque):** Use for applications where the motor load varies as the speed of the motor varies and fast response of the drive to motor speed command changes is not required. Can only be used when a single motor is connected to the drive. (Fans and pumps)
- Volts/Hz:** Use for multiple motor applications where more than one motor is connected to the drive. Also use the Volts / Hertz mode if the motor horsepower rating and the drive horsepower rating differ by more than 1 horsepower size.



**Note: Auto Tuning cannot be carried out in V/F Mode. "Err2" will be displayed.**





### Step-by-Step Procedure for Step 3

- a) Enter the drive Operating Mode in parameter 0-00.  
0-00 = 0000 Vector (General Purpose) "Default Setting".  
0-00 = 0001 Vector (Variable Torque).  
0-00 = 0002 Volts / Hz.
- b) If a value of 0002 (Volts/Hz) was entered for parameter 0-00, then skip to step K.
- c) Enter Motor Rated Voltage from motor nameplate in parameter 0-01.
- d) Enter Motor Rated Current from motor nameplate in parameter 0-02.
- e) Enter Motor Rated Kilowatts (kW=HPx.746) from motor nameplate in parameter 0-03.
- f) Enter Motor Rated Speed (RPM) from motor nameplate in parameter 0-04.
- g) Enter Motor Rated Frequency from motor nameplate in parameter 0-05.
- h) Set parameter 0-06 equal to 0001 (enable auto tuning). Press the  key and the auto tuning function will start and the display will read " - At -".
- i) The motor will not rotate during the auto tuning process but voltage will be applied to the motor.
- j) When the auto tuning is successful, the display will read parameter 0-06. Otherwise an auto tuning error will be displayed. Press the  key until the display reads "5.00" (frequency reference). Setup is completed. Skip the remaining steps K through O).
- k) For Volts / Hz Operation, Select a pattern in parameter 10-0 = 0-18 (See page 73-75 of the instruction manual for more detailed information) each pattern selects default values for parameters 10 - 1 through 10-9. These values may require tuning to meet your application speed and torque requirements.
- l) Parameter 10-0 = 18, allows for a custom Volts/Hz pattern to be entered in parameters 10-4 to 10-9 to meet specific applications. Refer to page 73 of the instruction manual.
- m) If the motor rated frequency is not 50 or 60 Hertz, adjust parameter 10 - 4 to the desired motor rated frequency.
- n) If you wish to operate the motor at a frequency higher than the motor rated frequency, adjust parameter 3-00 to the maximum frequency desired.
- o) Press the  key until the display reads "5.00" (frequency reference). Setup is now completed.

### Step 4 Check Motor Rotation

- Press RUN key (FWD LED should light), motor should start running, and the digital operator should display a value increasing from 00.00 to 05.00.
- **Check Motor Rotation.**  
If the motor does not rotate in the correct direction:  
Press STOP key. Remove AC power. Wait for LED "charge" lamp to extinguish.  
Reverse motor leads T1 and T2. Restart the drive and check the rotation.
- **Press STOP key to stop the drive.**

## Step 5 Check Full Speed at 50Hz/60Hz

- Frequency/Speed can be changed by pressing the  or  keys. To move left for next digit, press  key. Press the  key to set the speed.
- Set frequency to 50Hz/60Hz as applicable.
- Press RUN key and check drive acceleration to full speed.
- Press STOP key to stop drive and check deceleration.
- Display should now read the last set frequency.

## Step 6 Other Operations

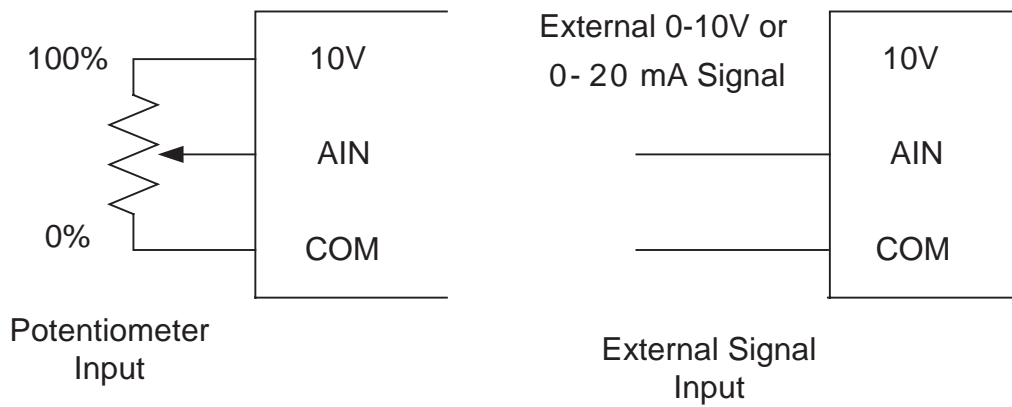

The drive is now setup for basic Run/Stop operation in both forward and reverse directions from the keypad. For other motor control options see below.

- a) **Disable Reverse Operation:** Set parameter 1-02 equal to 0001 to disable reverse operation. When set, the FWD/REV button on the keypad will no longer function and any external reverse commands will stop the motor. Refer to page 53 of the instruction manual.
- b) **Change Acceleration Time:** Parameter 3-02 sets the acceleration time in seconds. Acceleration Time is defined as the length of time to accelerate the motor from zero speed to Motor Rated Speed. Refer to page 56 of the instruction manual.
- c) **Change Deceleration Time:** Parameter 3-03 sets the deceleration time in seconds. Deceleration Time is defined as the length of time to decelerate the motor from Motor Rated Speed to zero speed. Refer to page 56 of the instruction manual.
- d) **Set Maximum Speed:** Parameter 3-00 sets the maximum output frequency to the motor. If Parameter 3-00 is set greater than the Motor Rated Frequency (parameter 0-05 for vector modes, parameter 10-4 for Volts/Hz mode), the motor will operate in the constant horsepower mode when motor rated frequency is exceeded. Refer to pages 51, 56 and 73 of the instruction manual.
- e) **Set Minimum Speed:** Parameter 3-01 sets the minimum output frequency to the motor. Refer to page 56 of the instruction manual.
- f) **Local / Remote Selection:** By default, the drive is configured to use the UP/DOWN keys on the keypad (Local Control) to set the Frequency Reference (motor speed command) for the drive and the RUN/STOP key to control the starting and stopping of the motor (Local Control). Once parameters 1-00 and 1-06 are set to any value other than 0000, the drive recognizes it as REMOTE CONTROL. By pressing the RESET and FWD/REV keys simultaneously the drive switches between LOCAL CONTROL and REMOTE CONTROL or vice versa.  
**Note: Parameter 1-00 and 1-06 must be set to remote in order for this function to take effect.**
- g) **Set Frequency Reference Source:** Change parameter 1-06 to change the frequency reference source as shown below. After setting parameter 1-06, remove AC input power, wait for the "Charged" LED to extinguish, and connect any devices to the drive as shown in Fig. 1. Reference to page 53 of the instruction manual.
  - 1) Parameter 1-06 = 0000: The Up/Down Arrow Keys on the keypad set the Frequency Reference Command. **Default Setting.**
  - 2) Parameter 1-06 = 0001: The Potentiometer Mounted on the Keypad sets the Frequency Reference Command.
  - 3) Parameter 1-06 = 0002: The Analog Voltage/Current connected to Terminal AIN sets the Frequency Reference Command.



**Figure 1**

Set SW2 switch per Table 1 based on the type of analog signal connected to the drive (use 0 - 10 VDC position for potentiometer input).

	Type of external signal	Remarks
	0~10VDC analog signal	External control is 1-06=0002
	0~20mA analog signal	

**Table 1**

4) Parameter 1-06 = 0003: The Up/Down Digital Inputs (Digital Input Function Codes 14 and 15) set the Frequency Command. Set Parameters 5-03 to 0014 and 5-04 to 0015 and connect Up / Down pushbuttons to the drive as shown below in Fig 2.

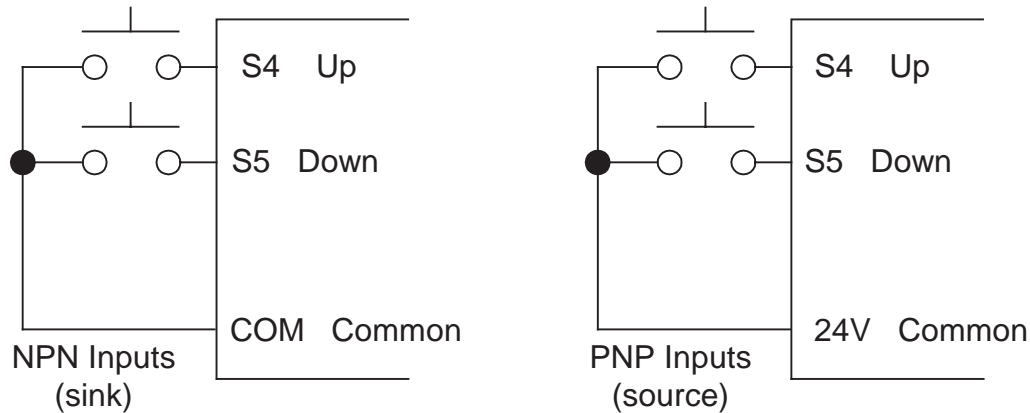



Figure 2

5) Parameter 1 - 06 = 0004: Serial Communications set the Frequency Command. Refer to the serial communications document for more detailed information.

**h) Set for External Start / Stop Control:** By default, the drive is configured to use the keypad pushbuttons to start and stop the drive. To enable starting and stopping the drive using external switches or pushbuttons, set parameter 1-00 equal to 0001 (External Terminal Control) and set parameter 1 - 01 to the desired value as described below. After setting parameters 1-00 and 1-01, remove AC input power, wait for the "Charged" LED to extinguish, and connect the switches or pushbuttons as shown in Figures 3-A, 3-B, and 3-C. Reference page 52 of the CV10 instruction manual for more detailed information.

**Set Switch SW1 according to the desired type of digital input used:**

SW1	Type of external signal	Remarks
 NPN	NPN input (sink) (Zero volts on the input terminal is ON)	Active Low
 PNP	PNP input (source) (24 VDC on the input terminal is ON)	Active High Factory default

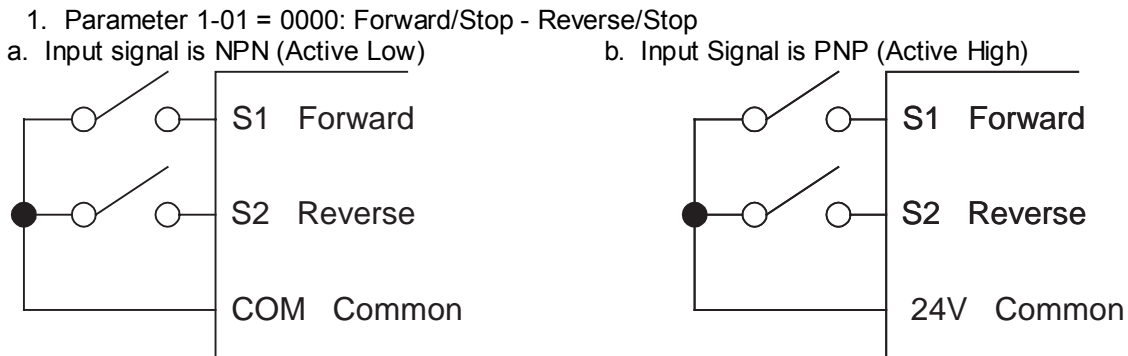

**Figure 3-A**

If both forward and reverse commands are applied at the same time, the drive will stop. Functions of Digital Inputs S1 and S2 are overridden by this command.

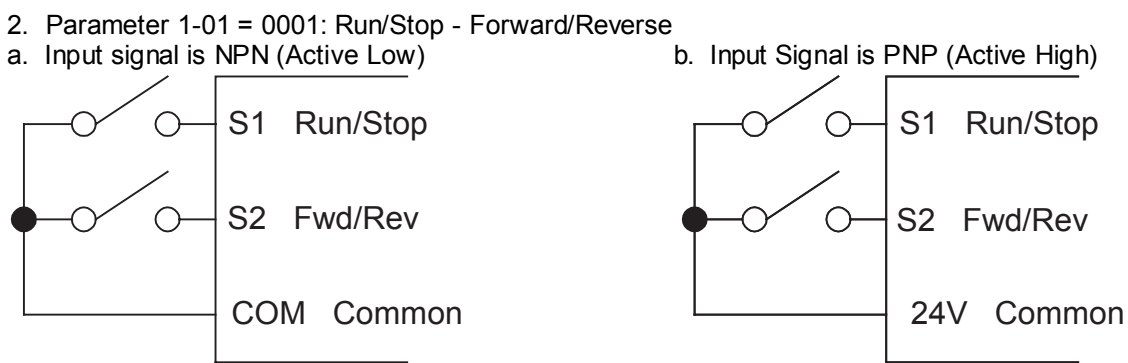

**Figure 3-B**

Functions of Digital Inputs S1 and S2 are overridden by this command.

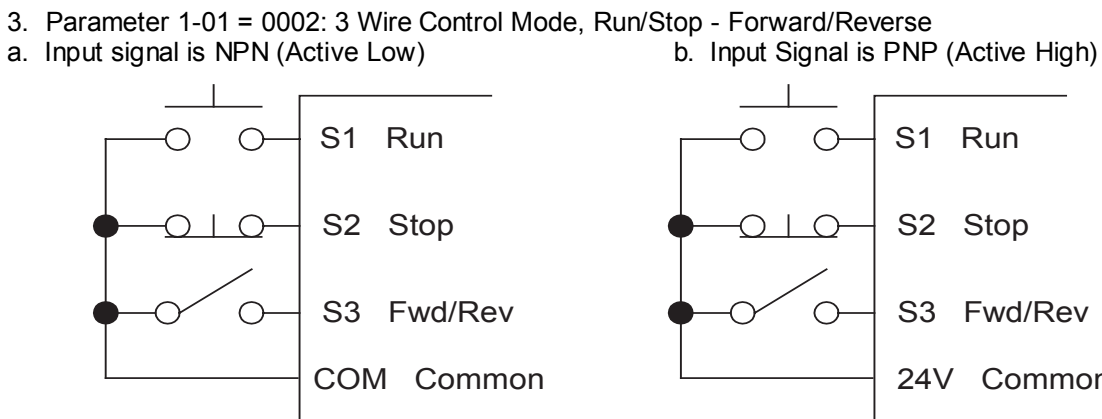

**Figure 3-C**

Functions of Digital Inputs S1, S2, and S3 are overridden by this command.

**Note:** If parameter 1-02 = 0001, then the reverse commands in all of the above figures will act like a stop command.