



**www.saftronics.com**

**START-UP PROCEDURE  
FOR THE  
GP10 CT/VT**

**TABLE OF CONTENTS**

	<b>PAGE</b>
INSTALLATION	2
EXAMPLE 1: Start/Stop & Speed Changes via the Keypad (Out of Box)	4
EXAMPLE 2: Remote Start/Stop (2-wire) & Speed Changes via Keypad	5
EXAMPLE 3: Remote Start/Stop (3-wire) & Speed Changes via the Keypad	6
EXAMPLE 4: Remote Start/Stop (3-wire) & Speed Changes via a Remote Source	7
EXAMPLE 5: Remote Start/Stop (3-wire) & Speed Changes via the Speed Pot	8
EXAMPLE 6: Remote Start/Stop (2-wire) & Speed Changes via external source with 3 Present Speeds	9
ADJUSTING THE TRIM POT.	
WARNING	11

**Saftronics, Inc.**

5580 Enterprise Pkwy., Ft. Myers, FL 33905

Telephone: (941) 693-7200

Fax: (941) 693-2431

P/N 027-2121

## Start-Up Procedure for the GP10

The following procedure is to assist in the start-up of the GP10 drive, by providing a step by step guide to installation, programming and basic operation of the GP10 drive. The procedure is based on several common configurations used in manufacturing. For more detailed configurations and applications, refer to the GP10 instruction manual (Part # 027-GP1001) available at www.saftronics.com.

### Installation

1. Verify that the input voltage of the supply, motor and the drive model number are all marked with the same voltage. Caution: If improper voltage is applied to the inverter, severe damage will result.
2. Mount the drive on a vertical surface with adequate space for proper air circulation (minimum 2 inches on each side for 40Hp and above, and 4 inches above and below; (Instruction Manual Page 2-1).
3. Remove the front cover, connect conduit to the bottom plate, and connect power, motor and ground wires to the correct terminals.
  - A. Check for short circuits and ground faults in the power system.
  - B. Check for loose terminals, connectors, or screws.
  - C. Turn off switches to prevent the motor from starting upon power up.

**Caution: Connect correct input voltage to terminal L1, L2, and L3.  
Connect motor to terminals U, V and W only or severe damage will result.**

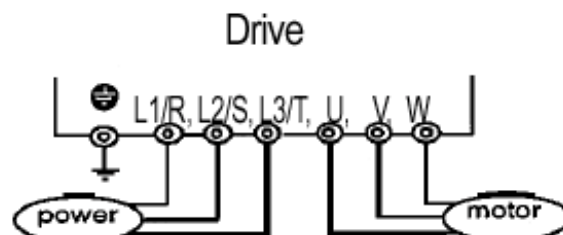

4. Turn power on and confirm the frequency display, 0.00Hz is blinking on the LED monitor on the keypad.
5. Set the frequency to about 5Hz using ▲ key.
6. To run the motor press the **FWD** key and the **STOP** key to stop operation of the motor.
7. Check the following items:
  - A. Is the direction rotation correct?
  - B. Is the rotation smooth (no buzzing or abnormal vibration)?
  - C. Acceleration or deceleration smooth? If abnormality is detected, increase the frequency and check the above items again.
8. If the above procedure is successful then proceed through the Start-up guide.  
If an error is detected during above procedure, immediately stop operation and attempt to determine the cause of the error by referring to Chapter 7, Troubleshooting, in the GP10 instruction manual.

6. Choose a Configuration from the table below. Each example listed contains a control wiring diagram, operation explanation, and all the necessary programming (associated with that mode). The GP10 drive can be configured in several more modes than explained in the start-up guide. The following configurations are generally considered the most commonly used in the field. For a more complete explanation, please refer to the GP10 Instruction Manual, Part # 027-GP1001, or download a copy from our website, www.saftronics.com.

**Table A: Inverter Configuration Examples**

Sequence (Start/Stop)	Reference (Speed Changes)	Description	Example Page
Keypad	Keypad	No control wiring needed to perform initial start-up and check rotation of the motor.	Example 1 Page 2
2-wire	Keypad	Start/Stop via the remote contact (PLC), speed changes via the keypad .	Example 2 Page 3
3-wire	Keypad	Start/Stop via the remote pushbuttons, speed changes via the keypad.	Example 3 Page 4
2-wire	4 to 20mA	Start/Stop and speed changes from a remote source such as a PLC.	Example 4 Page 6
3-wire	0 to 10Vdc (Speed Pot.)	Start/Stop via the remote pushbuttons, speed changes via a remote speed pot. or external source (0 to10Vdc).	Example 5 Page 7
2-wire	Contact Closures	Start/Stop via the remote contact (PLC) and speed changes via present speeds or analog reference.	Example 6 Page 9

7. Control Terminal Wiring- Remove power and wait until the *Charge* LED goes out before making control connections. The size of the control wiring should be between 16AWG and 20AWG wire. All control wiring should be shielded, with the shield grounded to the inverter's chassis ground and the other end left unconnected. All the control wiring terminates on the terminal strip located on the control card (the card that plugs into the keypad).

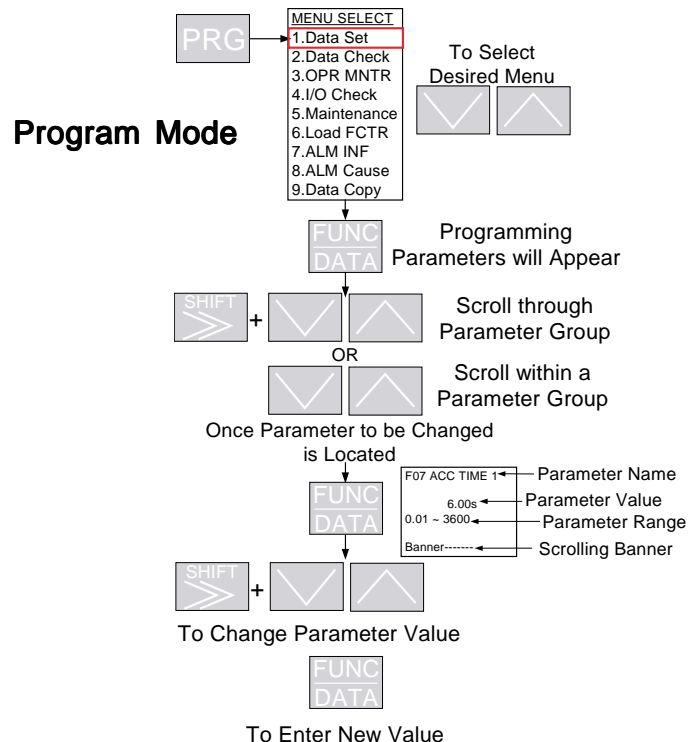
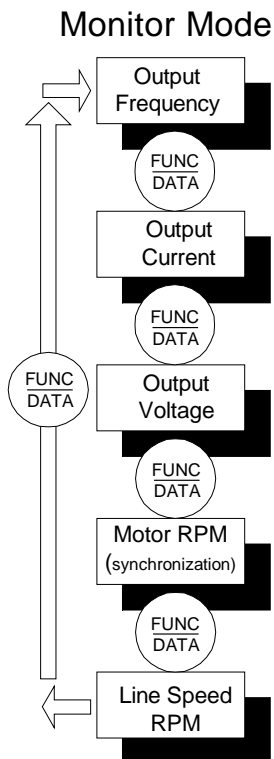

### Example 1: Start/Stop & Speed Changes via the Keypad (Out of Box)

When the inverter is set up with the operation method (start/stop) and the frequency setting (speed changes) via the keypad, that is considered local mode. Local mode is generally used during initial start up or to check the rotation of the motor. The drive can be easily put into local mode by pressing the **STOP** and **RESET** keys simultaneously. If power is removed and then restored, the inverter will come up in local mode (default mode).

### Operation

The frequency setting (speed change) is programmed into keypad using the ▲ or ▼ keys.

The inverter can be started by pressing the **FWD** key on the keypad.

The inverter can be stopped by pressing the **STOP** key on the keypad.

The direction of the motor may be changed, regardless of the motor speed, by pressing the **FWD** or **REV** key.

**Table 1: Programming for Local Mode (Keypad control)**

Parameter	Display Text	Description
F001	0=Default Setting	Sets the frequency setting (Speed Change) via the keypad.
F002	0=Default Setting	Sets the operation method (start/stop) via the keypad.
F07/F08	Acc Time1 Dec Time1	Acceleration Time and Deceleration Time / from stop to full speed.
F011	Motor Rated FLA = X.XA	Enter Full load amps from the motor nameplate data (this sets the motor protection OL1 level).

**Example 2: Remote Start/Stop (2-wire) & Speed Changes via Keypad**

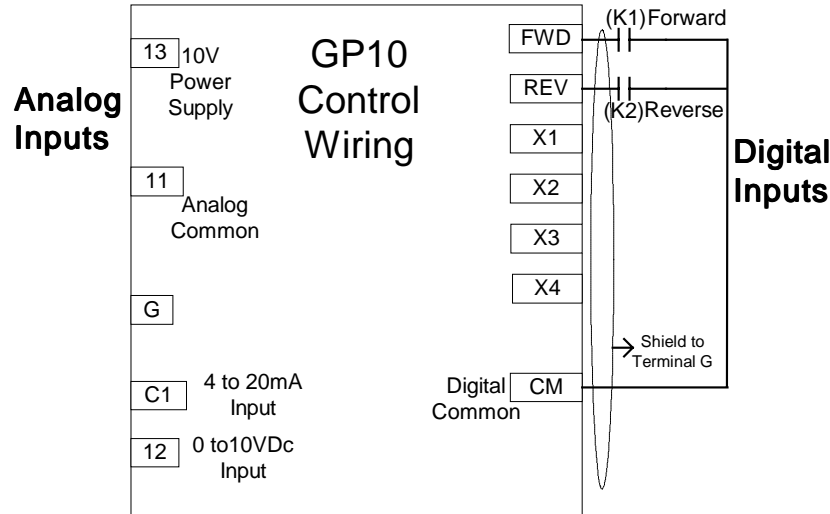

This configuration is used when the operation method (Start/Stop) is via an external source such as a PLC or relay type input. It can also be used with a maintained switch when it is desirable to have the inverter restart on the return of power. It should not be used where the safety of personnel might be threatened by the automatic restart of the machine.

**Operation**

Frequency reference (speed change) is programmed into keypad via the ▲ and ▼ keys.

Close (K1) to run in the forward direction at the speed set by the keypad.

Close (K2) to run in the reverse direction at the speed set by the keypad.

**Table 2: Programming needed for remote Start/Stop (2-wire) and Speed Changes via the Keypad**

Parameter	Display	Description
H03	1 Hold <b>STOP</b> key and <b>UP</b> key to change	The inverter will perform a data initialization (default 2 wire control). CAUTION: This parameter sets all parameters to their factory settings and all previous settings will be lost. When the inverter completes the reset, the parameter returns to a value of 0.
F01	0	Frequency Setting (speed change) via the keypad.
F02	1	Operation method (start/stop) via the terminals (stop key active).
F11	Motor Rated FLA X.X A	Enter the full load amps from the motor nameplate. (this sets the motor protection level OL1).
Default Display	(Digital Set Hz) Local	Sets the desired frequency reference (speed). Settable by pressing the <b>UP</b> and <b>DOWN</b> keys to set the frequency.

**Example 3: Remote Start/Stop (3-wire) & Speed changes via the Keypad**

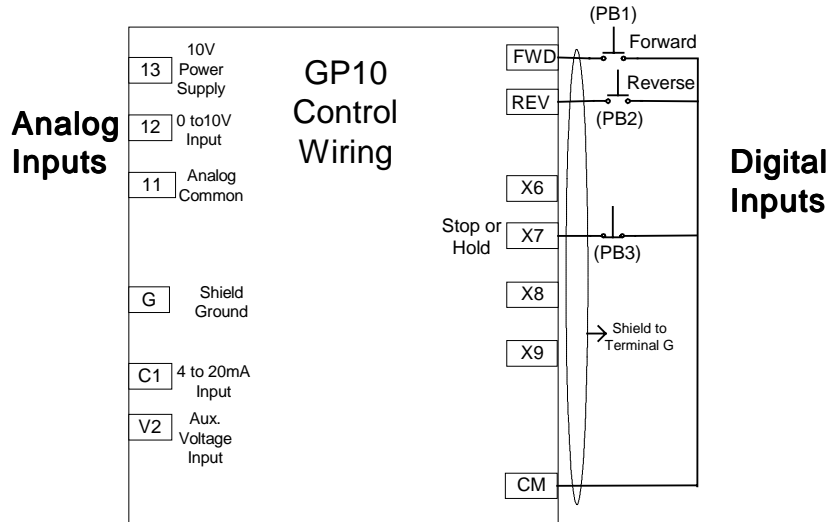

This mode is commonly used when a drive is replacing existing equipment such as an across the line starter and the application requires minimal to no speed changes.

**Operation**

The frequency setting (speed change) is programmed via the **UP** or **DOWN** keys on the keypad.

By momentarily closing push-button (PB1), while push-button (PB3) is closed, the inverter will run up to the frequency setting.

By opening push-button (PB3) at any time, the inverter will decelerate to a stop.

By momentarily closing push-button (PB2), while push-button (PB3) is closed, the inverter will reverse it's direction.

**Table 3: Programming Needed for Start/Stop (3-wire) and Speed Changes via the Keypad**

Parameter	Display	Description
H03	1 Hold STOP key and UP key to change	The inverter will perform a data initialization. CAUTION: This parameter sets all parameters to their factory settings and all previous settings will be lost. When the inverter completes the reset, the parameter returns to a value of 0.
F01	0	Frequency Setting (Speed Change) via the keypad.
F02	1	Operation method (start/stop) via the terminals (stop key active).
F11	Motor Rated FLA X.X A	Enter the full load amps from the motor nameplate. (This sets the motor protection level OL1).
Default Display	DIG. SET Hz LOCAL	Sets the desired frequency reference (speed). Settable by pressing the <b>UP</b> and <b>DOWN</b> keys to set the frequency.

**Example 4: Remote Start/Stop (2-wire) & Speed Changes via a Remote Source**

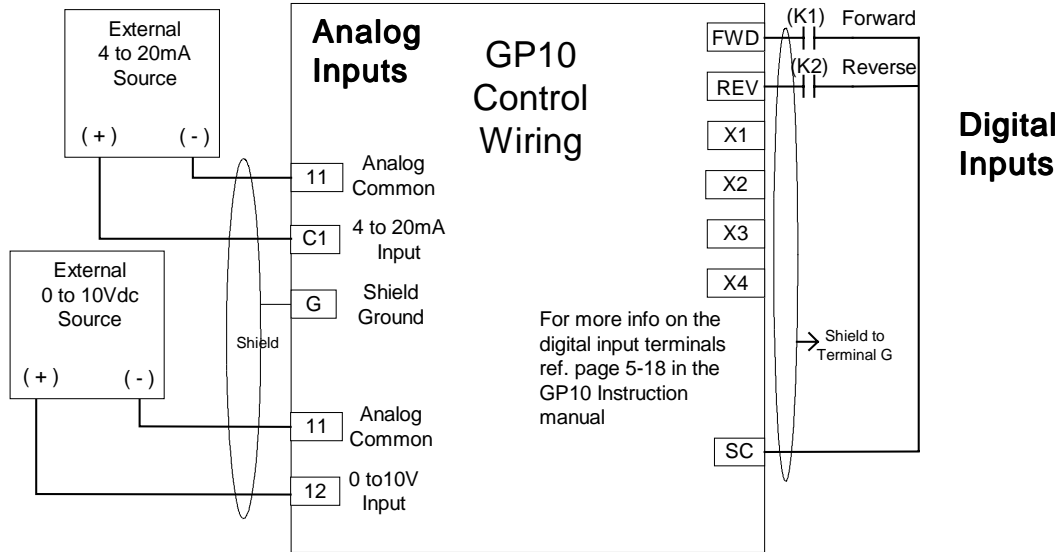

This configuration is used when the start & stop signals and the speed changes originate from a remote source such as a controller or PLC. It can also be used with a maintained switch, when it is desirable to have the drive restart on restoration of power. It should not be used where the safety of the attending personnel might be threatened by the automatic restart of the motor.

**Operation**

Close (K1) to run in the forward direction.

Close (K2) to run in the reverse direction.

The frequency of the inverter will be proportional to the signal level on terminal F1 ( 4mA=0Hz 12mA=30Hz & 20mA =60Hz) or terminal 12 (0V=0Hz, 5V=30Hz & 10V=60Hz).

When the **STOP** and **RESET** key are pressed the inverter will act as Example 1 (local mode).

**Table 4: Programming needed for remote Start/Stop (2-wire) with 4 to 20mA and 0 to10V signal for Speed Changes**

Parameter	Display	Description
H03	1 Hold <b>Stop</b> key and <b>UP</b> key to change value	The inverter will perform a data initialization. CAUTION: This parameter sets all parameters to their factory settings and all previous settings will be lost. When the inverter completes the reset, the parameter returns to a value of 0.
F01	3	Frequency Setting (speed change) via the terminal 12 and C1.
F02	1	Operation method start stop) via the terminals (STOP key active).
F11	Motor Rated FLA X.X A	Enter the full load amps from the motor nameplate (this sets the motor protection level OL1).

**Example 5: Remote Start/Stop (3-wire) & Speed Changes via the Speed Pot**

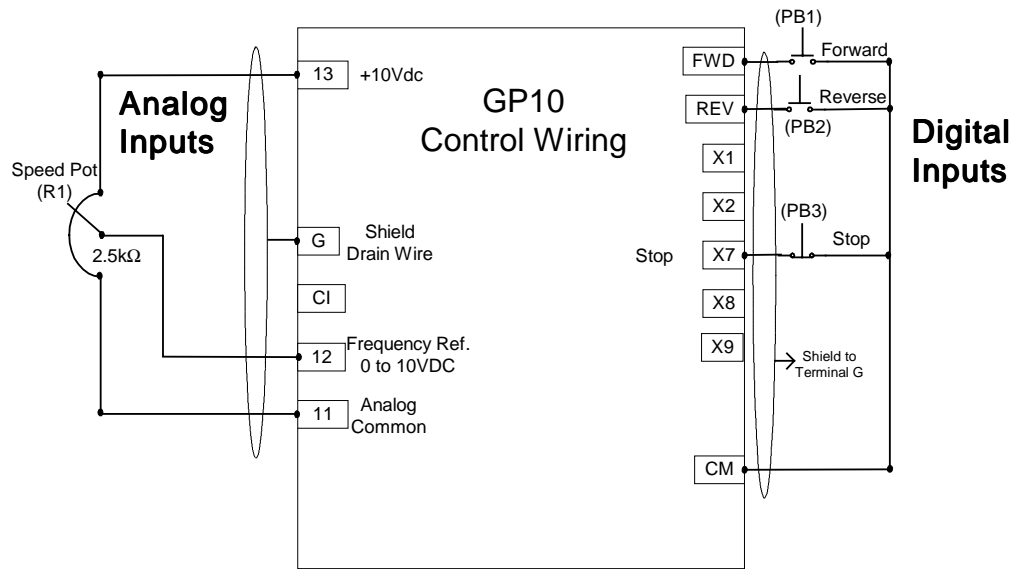

This configuration is best utilized when a person has control of the inverter and the application. Both potentiometers should be rated between 2kΩ and 5kΩ of resistance and rated at least 1/4 Watt each.

**Operation**

By momentarily closing push-button (PB1), while push-button (PB3) is closed, the inverter will run up to the frequency setting via the speed potentiometer.

By opening push-button (PB3) at any time, the inverter will decelerate to a stop.

By momentarily closing push-button (PB2), while push-button (PB3) is closed, the inverter will reverse it's direction.

The frequency reference (speed) is proportional to the signal level present on terminal 12  
0V=0Hz, 5V=30Hz and 10V=60Hz.

When the **STOP** and **RESET** key is pressed, the inverter will act as Example 1(local mode).

**Table 5: Programming needed for Remote (3-wire) & Speed Changes via Speed Potentiometer**

Parameter	Display	Description
H03	1 Hold <b>STOP</b> key and <b>UP</b> key to change	The inverter will perform a data initialization. CAUTION: This parameter sets all parameters to their factory settings and all previous settings will be lost. When the inverter completes the reset, the parameter returns to a value of 0.
F01	1	Frequency Setting (speed changes) via the terminals.
F02	1	Operation method (start/stop) via the terminals (STOP key active).
F07/F08	Acc Time1 Dec Time1	Acceleration Time and Deceleration Time / From stop to full speed.
F11	Motor Rated FLA X.X A	Enter the full load amps from the motor nameplate (this sets the motor protection level OL1).

**Example 6: Remote Start/Stop (2-wire) & Speed Changes via external source with 3 Present Speeds**

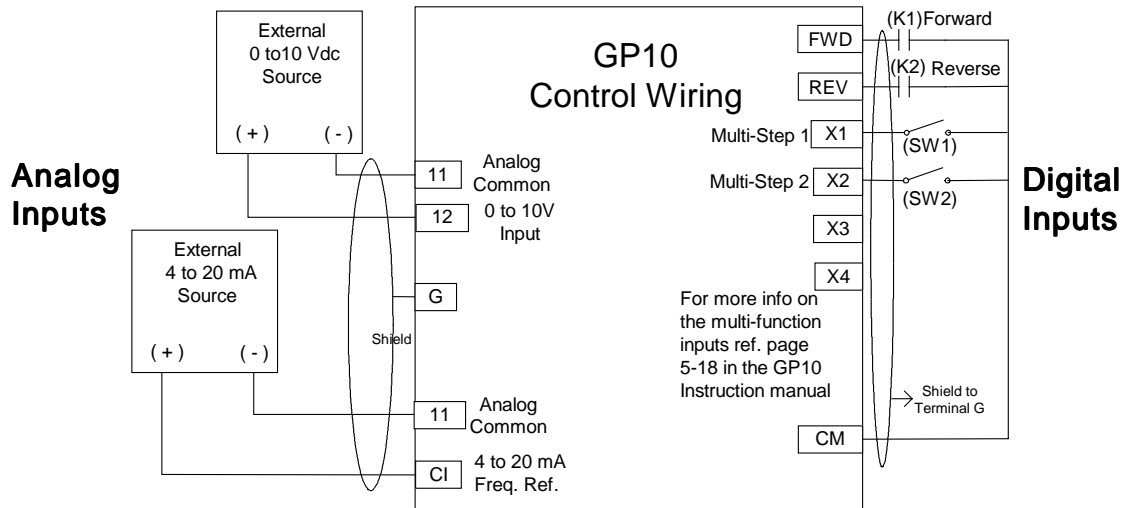

This configuration is generally used when the inverter is controlled via a remote source such as a PLC. It can also be used with a maintained switch when it is desirable to have the drive restart on restoration of power. It should not be used where the safety of the attending personnel might be threatened by automatic restart. Up to three speeds can be selected by using the switches SW1-SW2 to select the desired speed.

**Operation**

Close (K1) to run in the forward direction.

Close (K2) to run in the reverse direction.

The frequency of the inverter will be proportional to the signal level on terminal 12 or CI (0Vdc=0Hz, 5Vdc=30Hz & 10Vdc =60Hz) or (4mA=0Hz, 12mA=30Hz and 20mA=60Hz).

By closing any of the switches (SW1-SW2) and closing either (K1) or (K2) to determine the direction, the inverter will run at a present speed.

When the **STOP** and **RESET** key is pressed, the inverter will act as Example 1(local mode).

**Table 6: Programming needed for Remote Start/Stop (2-wire) & Multiple Inputs for Speed Changes**

Parameter	Display	Description
H03	1 Hold <b>STOP</b> key and <b>UP</b> key to change value	The inverter will perform a data initialization. CAUTION: This parameter sets all parameters to their factory settings and all previous settings will be lost. When the inverter completes the reset, the parameter returns to a value of 0.
F01	3	Frequency Setting (speed change) via terminal 12 and C1.
F02	1	Operation Command (Start/Stop) via the terminals.
F08/F09	Acc Time1 Dec Time1	Acceleration Time and Deceleration Time / From stop to full speed.
F11	Motor Rated FLA X.X A	Enter the full load amps from the motor nameplate (this sets the motor protection level OL1).
C05	Reference 1 X.X Hz	Sets the Frequency Reference (speed) when SW1 is closed and SW2 is open.
C06	Reference 2 X.X Hz	Sets the Frequency Reference (speed) when SW2 is closed and SW1 is open.
C07	Reference 3 X.X Hz	Sets the Frequency Reference (speed) when SW1 and SW2 are closed.

**Table 7 : Truth Table for Present Speeds**

SW1 Status	SW2 Status	Reference Source
Open	Open	Analog value present on Terminal FV
Closed	Open	Frequency stored in Parameter C05
Open	Closed	Frequency stored in Parameter C06
Closed	Closed	Frequency stored in Parameter C07

**Note:** Underlined words indicate keys on the keypad.

## **WARNING!**

*Saftronics* manufactures component parts that can be used in a wide variety of industrial applications. The selection and application of *Saftronics* products remains the responsibility of the equipment designer or end user. *Saftronics* accepts no responsibility for how its products may be incorporated into the final design.

Under no circumstances should any *Saftronics* product be incorporated into any product or design as the exclusive or sole safety control. Without exception, all controls should be designed to dynamically fault detect and fail safe under all circumstances. All products designed to incorporate a component part manufactured by *Saftronics*, must be supplied to the end user with appropriate warnings and instructions as to the safe use and operation. Any warnings provided by *Saftronics* must be passed through to the end user.

*Saftronics* offers an express warranty only as to the quality of its products to conform to the catalog specifications. **NO OTHER WARRANTY EXPRESS OR IMPLIED IS OFFERED.** *Saftronics* assumes no liability for any personal injury, property damage, losses or claims, arising out of the misapplication of its products.

For more info visit [www.saftronics.com](http://www.saftronics.com)