



## **INSTRUCTION MANUAL**

DOCUMENT NO. 027-0169  
Rev. 1.02 July 31, 2003

# **24 / 120 VAC Input + Relay Option Card for the PC10**

**Part Number 100-0169-01**

### **Saftronics, Inc.**

5580 Enterprise Pkwy  
Ft. Myers, FL 33905  
Tel. (239) 693 - 7200  
Fax (239) 639 - 2431  
[www.saftronics.com](http://www.saftronics.com)

## **LETHAL VOLTAGES MAY BE PRESENT**

**PLEASE READ THIS MANUAL THOROUGHLY BEFORE ATTEMPTING ANY INSTALLATION, OPERATION, MAINTENANCE, OR INSPECTION. FAILURE TO FOLLOW THE RECOMMENDED PROCEDURES OR CAUTIONS IN THIS MANUAL COULD RESULT IN INJURY TO PERSONNEL AND / OR DAMAGE TO THE EQUIPMENT.**

### **CAUTION**

- 1 – CHECK THE NAME WRITTEN ON THE PRODUCT AND INSURE THAT THE PROPER PART HAS BEEN RECEIVED.
- 2 – THOROUGHLY INSPECT THE PART(S) FOR ANY DAMAGE DUE TO SHIPMENT OR HANDLING.
- 3 - THE PART(S) MAY CONTAIN CMOS CHIPS AND CAN BE DAMGED BY STATIC ELECTRICITY. HANDLING SHOULD BE IN ACCORDANCE WITH INDUSTRY STANDARDS.
- 4 - BEFORE INSTALLING THE PART(S) TURN OFF ALL POWER TO THE EQUIPMENT AND INSURE THE CHARGE INDICATOR LAMP ON THE INVERTER IS **OFF**. **LETHAL VOLTAGES ARE PRESENT**
- 5 - DO NOT CONNECT OR DISCONNECT WIRING WHILE POWER IS **ON!**
- 6 - FOLLOW GOOD STANDARD WIRING PRACTICES AND ANY APPLICABLE CODES THAT MAY APPLY.

## PC10 24/120V INPUT + RELAY CARD P/N 100-0169-01

### Description

The **100-0169-01** 24/120V INPUT + RELAY CARD, provides for (5) 120V isolated Control inputs for the PC10 Inverter. It also provides (1) form C relay output. It has “hard pins” to assemble directly to the PC10’s control terminals and screw type output terminals.

### Specifications

<b>Input</b>	Input voltage range – 24 to 120 VAC Input Isolation - 5KVAC Input Resistance - 23Kohms
<b>Output Relay</b>	Form C contact, rated at 120 VAC @ 0.5A / 24 VAC @ 1.0A

### Installation

**Turn off all power to the equipment being worked on before attempting any installation.** Referring to the figure below and in accordance with the PC10 instruction manual, remove the protective cover. Insert the “hard pins” into terminals **CME, FWD, REV, CM** and **P24** of the PC10’s control terminals and tighten. Connect the pig-tail leads to terminals **Y1, X1, X2** and **X3**. In accordance with the application requirements, make the connections to the input screw terminals using good standard practices, following all applicable codes. Replace the cover. This completes the installation.

After applying power, input parameters **E01** to **E03** corresponding to **X1** to **X3**, and output parameter **E20** corresponding to **Y1** can be programmed in accordance with the application requirements. See the Table on page 2 and also refer to the **PC10** manual Sec. 5-2 for further details.

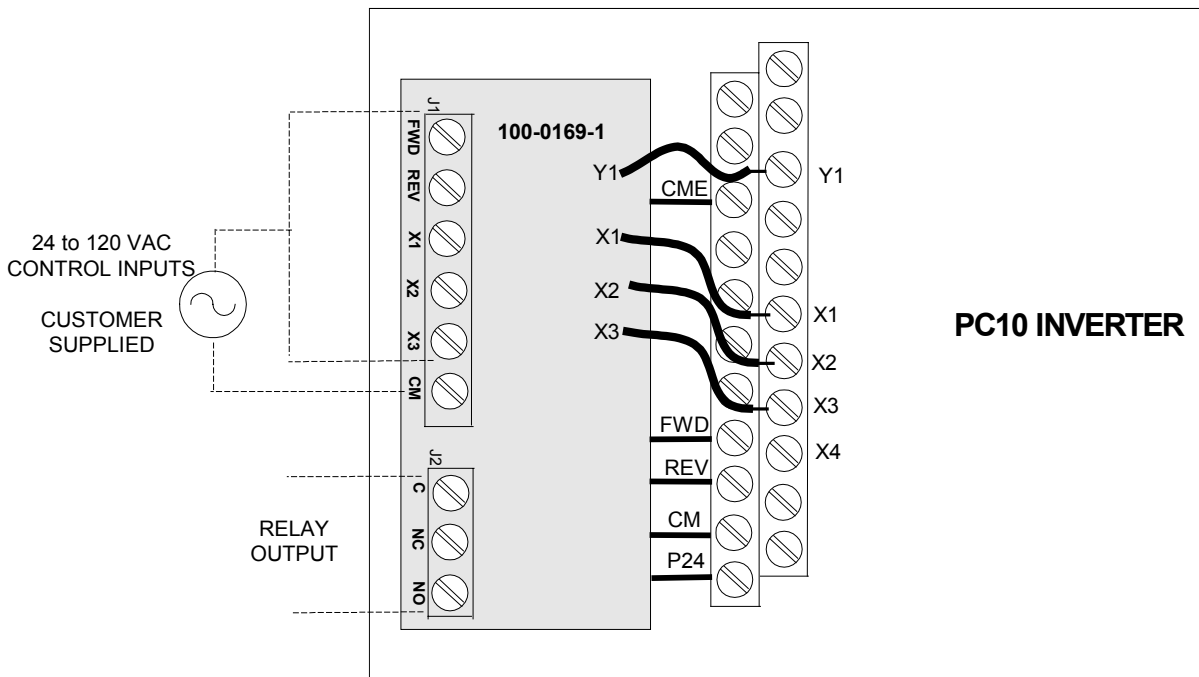

PC10 Extension terminal functions

Function Code	Name	Setting Range	Min. Unit	Factory Setting	Change During Operation
E01	X1 Terminal	0: Multistep frequency 1: Multistep frequency 2: Multistep frequency 3: Multistep frequency 4: Acceleration/deceleration time selection(RT1)	1	0	N
E02	X2 Terminal	5: Self holding or 3-wire operation stop / start operation (HLD) 6: Coast-to-stop command (BX) 7: Alarm reset (RST)		1	N
E03	X3 Terminal	8: Trip command (External fault) (THR) 9: Frequency setting 2 / Frequency setting 1 (Hz2/Hz1) 10: Motor 1 / Motor 2 (M2/M1) 11: DC injection brake command (DCBRK) 12: Torque limiter 1 / Torque limiter 2 (TL2/TL1)		2	N
		13: Up command (UP) 14: Down command (DOWN) 15: Write enable or Key 16: PID control cancel (HZ/PID) 17: Inverse mode changeover (IVS) (terminal 12 & C1) 18: Communications link enable (LE)			
E20	Y1 Terminal	0: Drive running (RUN) 1: Frequency arrival (FAR) 2: Frequency level detection (FDT) 3: Undervoltage detection signal (LV) 4: Torque polarity (B/D) 5: Torque limiting (TL) 6: Restart after momentary power failure (IPF) 7: Overload early warning (OL) 8: Life time alarm (LIFE) 9: Frequency level detection 2 (FAR2)	1	0	N

## **WARNING!**

*Saftronics* manufactures component parts that can be used in a wide variety of industrial applications. The selection and application of *Saftronics* products remains the responsibility of the equipment designer or end user. *Saftronics* accepts no responsibility for how its products may be incorporated into the final design.

Under no circumstances should any *Saftronics* product be incorporated into any product or design as the exclusive or sole safety control. Without exception, all controls should be designed to dynamically fault detect and fail safe under all circumstances. All products designed to incorporate a component part manufactured by *Saftronics*, must be supplied to the end user with appropriate warnings and instructions as to the safe use and operation. Any warnings provided by *Saftronics* must be passed through to the end user.

*Saftronics* offers an express warranty only as to the quality of its products to conform to the catalog specifications. NO OTHER WARRANTY, EXPRESS OR IMPLIED, IS OFFERED. *Saftronics* assumes no liability for any personal injury, property damage, losses or claims, arising out of the mis-application of its products.