



www.saftronics.com

PC10 NEMA 1/12 AC Inverter Keypad Extender Kit

Installation Instructions

Saftronics, Inc.

5580 Enterprise Pkwy., Ft. Myers, FL 33905

Telephone: (239) 693-7200

Fax: (239) 693-2431

www.saftronics.com

KIT NO. 043-1007

DOC. NO. 027-2158

SAFETY FIRST !

LETHAL VOLTAGES MAY BE PRESENT!

PLEASE READ THIS INSTRUCTION MANUAL THOROUGHLY BEFORE ATTEMPTING ANY INSTALLATION, OPERATION, MAINTENANCE OR INSPECTION. FAILURE TO FOLLOW THE RECOMMENDED PROCEDURES OR CAUTIONS IN THIS MANUAL COULD RESULT IN INJURY TO PERSONNEL AND/OR DAMAGE TO EQUIPMENT.

CAUTION !

1. CHECK THE NAME WRITTEN ON THE PRODUCTS AND INSURE THAT THE PROPER PART HAS BEEN RECEIVED.
2. THOROUGHLY INSPECT THE PART(S) FOR ANY DAMAGE DUE TO SHIPMENT OR HANDLING.
3. THE PART(S) MAY CONTAIN CMOS CHIPS AND CAN BE DAMAGED BY STATIC ELECTRICITY. HANDLING SHOULD BE IN ACCORDANCE WITH INDUSTRY STANDARDS.
4. BEFORE INSTALLING THE PART(S) TURN OFF ALL POWER TO THE EQUIPMENT AND INSURE THE CHARGE INDICATOR LAMP ON THE INVERTER IS **OFF**. **LETHAL VOLTAGES ARE PRESENT !**
5. DO NOT CONNECT OR DISCONNECT WIRING WHILE POWER IS **ON !**
6. FOLLOW GOOD STANDARD WIRING PRACTICES AND ANY APPLICABLE CODES THAT MAY APPLY.

OVERVIEW

Please carefully read this manual in its entirety before attempting the installation.

The **PC10** keypad extender kit allows the keypad to be remotely mounted from the inverter via a standard RJ45 cable. A 36 inch long cable is supplied with the kit as standard, but other lengths are available on special order.

KIT INCLUDES

- (1) P/N 003-1361 Bracket
- (1) P/N 034-4824 RJ45 Coupler
- (1) P/N 034-4823 Retainer clip
- * (1) P/N 018-9026 RJ45M to RJ45M 36 inch Connecting cable
- (2) P/N 020-0213 # 4-40 x 3/4 in. mounting screws

* A 36 inch cable is supplied as standard. Other length cables are available on special order up to 20 feet max. Please consult factory.

INSTALLATION PROCEDURE

REFERRING TO FIGURES 1 & 2

1. Power down the **PC10** and carefully remove the keypad from the Inverter by removing the two mounting screws. The screws will no longer be needed and may be discarded.
2. Assemble the Retainer Clip (P/N 034-4823) to the RJ45 Coupler (P/N 034-4824) in the bottom most groove to accommodate a 14 gauge (.075 in. thick) to 12 gauge (.105 in. thick) panel or door. The upper groove will accommodate up to 8 gauge (.157 in. thick).
3. Position the keypad on the panel where it is to be mounted and cut out panel in accordance with Fig. 1. **(Make sure that there is sufficient space to complete the assembly and that the distance between the Inverter and the keypad is within the limits of the cable length.)**

4. In accordance with Fig. 2 hold the keypad in the panel opening and with the retainer clip assembled to the coupler, push the coupler onto the keypad
5. Place the bracket over the coupler assembly as shown and secure with the two screws provided.
6. Connect the cable to the coupler and the inverter.
7. The inverter may now be powered up and checked.

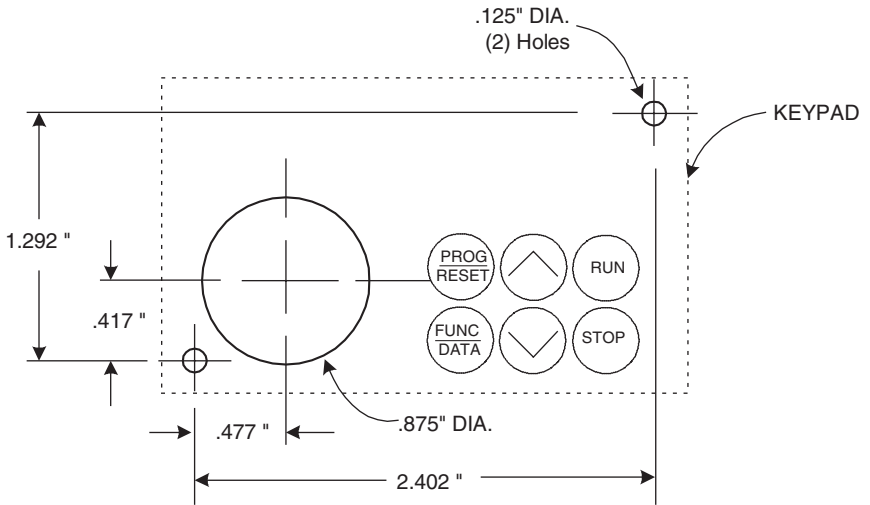

PANEL CUT-OUT

Scale 1:1 can be used as template

FIGURE 1

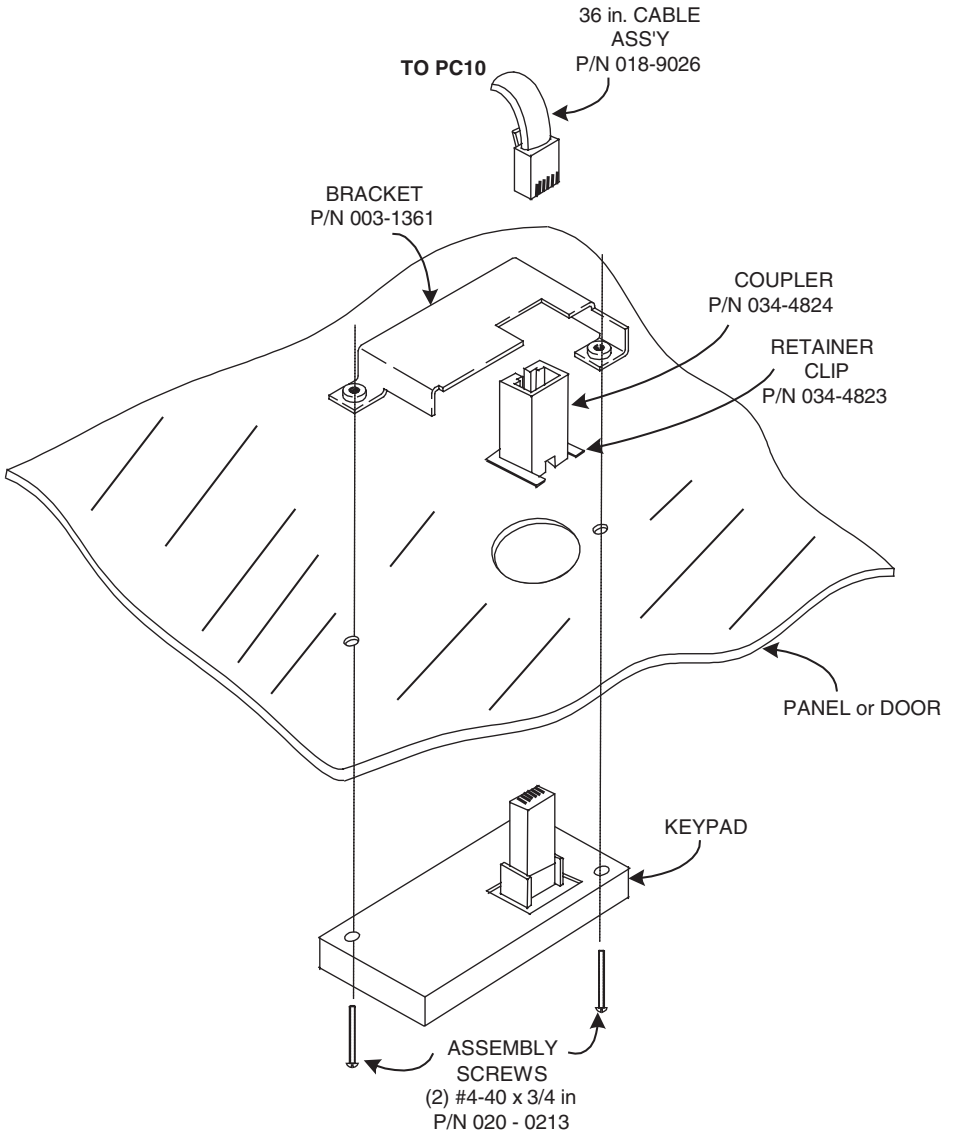

ASSEMBLY DWG.

FIGURE 2

WARNING!

Saftronics manufactures component parts that can be used in a wide variety of industrial applications. The selection and application of *Saftronics* products remains the responsibility of the equipment designer or end user. *Saftronics* accepts no responsibility for how its products may be incorporated into the final design.

Under no circumstances should any *Saftronics* product be incorporated into any product or design as the exclusive or sole safety control. Without exception, all controls should be designed to dynamically fault detect and fail safe under all circumstances. All products designed to incorporate a component part manufactured by *Saftronics*, must be supplied to the end user with appropriate warnings and instructions as to the safe use and operation. Any warnings provided by *Saftronics* must be passed through to the end user.

Saftronics offers an express warranty only as to the quality of its products to conform to the catalog specifications. **NO OTHER WARRANTY, EXPRESS OR IMPLIED, IS OFFERED.** *Saftronics* assumes no liability for any personal injury, property damage, losses or claims, arising out of the mis-application of its products.