

# PC10 Basic wiring diagram

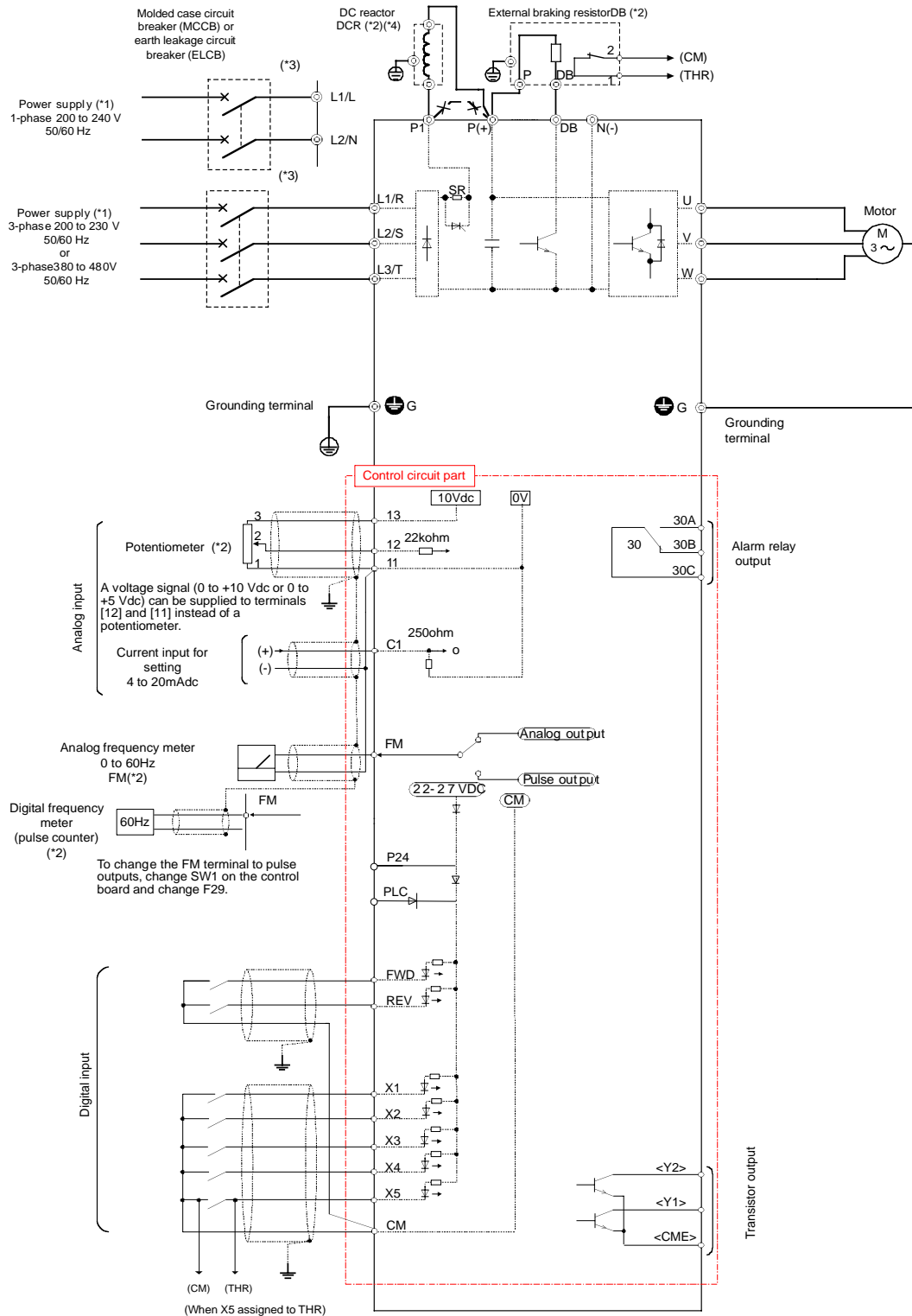

- \*1) Source voltage must be suitable for the rated voltage of the drive.
- \*2) Optional part. Use when necessary.
- \*3) Peripheral equipment. Use when necessary.
- \*4) To connect a DC reactor (DCR) for power factor correcting, remove the jumper between the P1 and P (+) terminals.