



[www.saftronics.com](http://www.saftronics.com)

## START-UP PROCEDURE

### FOR THE PC7

#### TABLE OF CONTENTS

	<b>PAGE</b>
INSTALLATION	2
EXAMPLE 1: Start/Stop and Speed changes via the Keypad	4
EXAMPLE 2: Remote Start/Stop (2-wire) & Speed Changes via External Source	5
EXAMPLE 3: 3-Wire Start/Stop with External Source	6
ADJUSTING THE TRIM POT.	7
WARNING	7

**Saftronics, Inc.**  
5580 Enterprise Pkwy., Ft. Myers, FL 33905  
Telephone: (941) 693-7200  
Fax: (941) 693-2431

P/N 027-2075

# Start-Up Procedure for the PC7

The following procedure is to assist in the start-up of the PC7 inverter by providing a step by step guide to installing, programming and using the PC7 inverter. The procedure is based on several common configurations used in the industry. For more detailed configurations and applications refer to the PC7 instruction manual (P/N 027-2045), available at [www.saftronics.com](http://www.saftronics.com).

## Installation

1. Verify that the input voltage of the supply, motor and the drive model number are all marked with the same voltage. Caution: If improper voltage is applied to the inverter, severe damage will result.
2. Mount the inverter on a vertical surface with adequate space for proper air circulation (minimum 1.18 inches on each side and 4 inches above and below; Instruction Manual Pg.1-3).
3. Remove the front cover by removing the screw in the lower left corner, then connect power and ground wires as shown. Caution: Connect correct input voltage to terminal L1, L2, and L3 or severe damage will result.

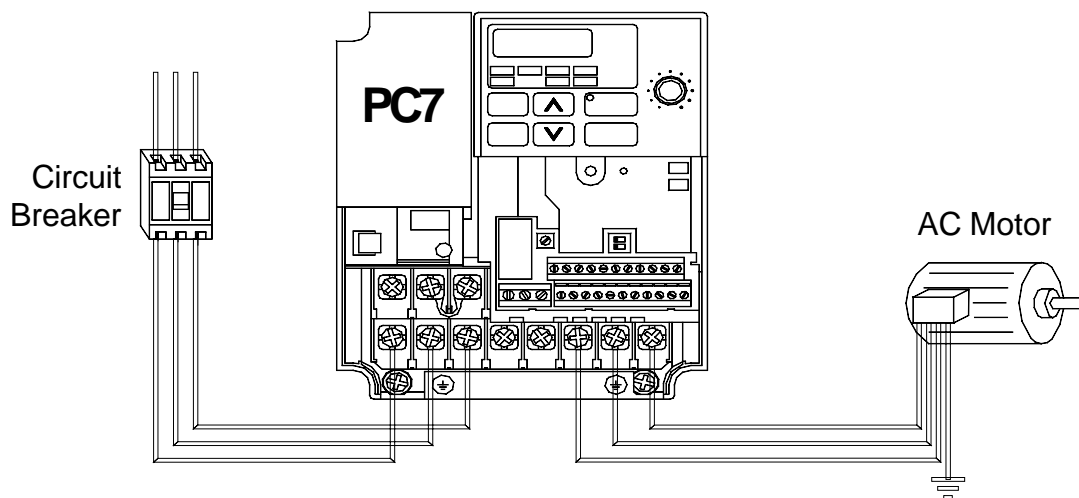

4. Replace the cover and apply input voltage. The keypad will display "0.0" and the *FREF*LED will be illuminated and the Run will be Flashing. Press the DSPL until the *LO/RE* (Local/Remote) is illuminated, use the ▲ key to change the value to LO (Local Mode), then press ENTER. Press the DSPL key until the *FREF* Led is illuminated, now turn the potentiometer until 10 Hz is displayed. Press the RUN key and check for rotation and direction of the motor, if rotation is not correct then remove power from the inverter and wait to the *Charge* LED to extinguish, then swap two motor leads at the output of the inverter (T1, T2, T3). Then reapply power and run the inverter and motor.

5. **Keypad**

The DSPL key scrolls through all of the LED's. To access a parameter, press the DSPL key until the *PRGM* LED is illuminated. Use the ▲ and ▼ keys until the desired parameter number is displayed then press ENTER. Use the ▲ and ▼ keys to adjust the value, then press ENTER, then DSPL. Before the drive will accept a Run command, one of the following LED's must be illuminated: *FREF*, *FOUT*, *IOUT*, *MNTR*, or *F/R*. For more detailed information refer to the PC7 Instruction Manual P/N 027-2045, Chapter 2.

6. Choose a configuration from the table below. Each example listed contains control wiring diagram, operation explanation, and all necessary programming. The PC7 can be configured in several more modes than are described in the following examples. The examples are the most common configurations that are used in the field.

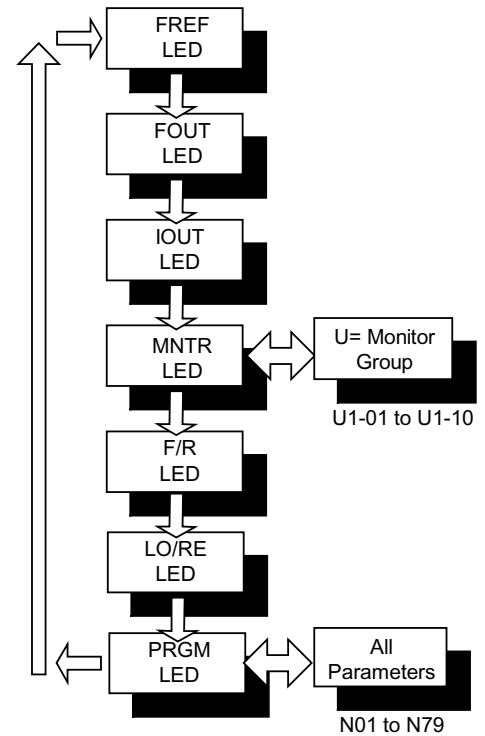

**Table A: Common drive configuration examples**

Sequence (Run Stop Signal)	Reference (Motor Speed)	Description
Keypad	Pot. on Keypad	This method requires no external wiring connections to the inverter. Commonly used to perform initial startup, (check rotation) out of the box configuration
2-Wire	4 to 20mA	With this method, the drive can be started and stopped from a remote source, and the reference is supplied via a 4 to 20mA source such as a PLC.
3-Wire	Speed Potentionmeter (0 to 10V)	With this method, remote pushbuttons start and stop the inverter and the reference is supplied by a speed potentiometer or an external supply (0 to 10Vdc) such as a process controller.

7. Control Terminal Wiring - Remove power and wait for all LED's to extinguish before connecting any control wiring on to the inverter. The control wires should be between 16 to 20 AWG wire. The analog signal on the control wiring needs to be shielded cable with the shield wire connected to the ground terminal, located on the left hand side of the heat sink.

### **Example 1: Start/Stop and Speed changes via the Keypad**

When the inverter is set up with the start/stop and the speed changes via the keypad, that is considered local mode. Local mode is most often used during initial start-up to check the motor operation and rotation of the shaft. The inverter is capable of running in local mode by simply using the *LO/RE* LED and switching it to LO. When power is removed and then reapplied the unit will default back to remote mode. The inverter is capable of staying in local mode after power is lost, Refer to Table 1 for the programming.

### **Operation**

The frequency reference (speed changes) via the speed pot. located on the keypad.

The inverter can be started by pressing the RUN button and stopped by pressing the STOP button on the keypad.

The direction of the motor can be changed regardless of the motor speed by going to the *F/R* LED, switching it to the other direction (FWD or REV).

**Table 1: Programming needed to operate via the keypad**

<b>Parameter</b>	<b>Display (Readout)</b>	<b>Description</b>
N03	0	This parameter sets the Run/Stop to Local control (keypad)
N04	0	This parameter sets the speed changes (shaft RPM) to control via the pot. on the keypad.
N19/20	xx.x Seconds	Acceleration time and deceleration times/ The time from stop to full speed.
N36	Motor Full Load Amps (FLA)	Enter the motor's FLA from the nameplate of the motor.
Quick Start LED	F/R	Motor direction can be changed regardless of the motor speed using the quick LED.

**Example 2: Remote Start/Stop (2-wire) & Speed Changes via External Source**

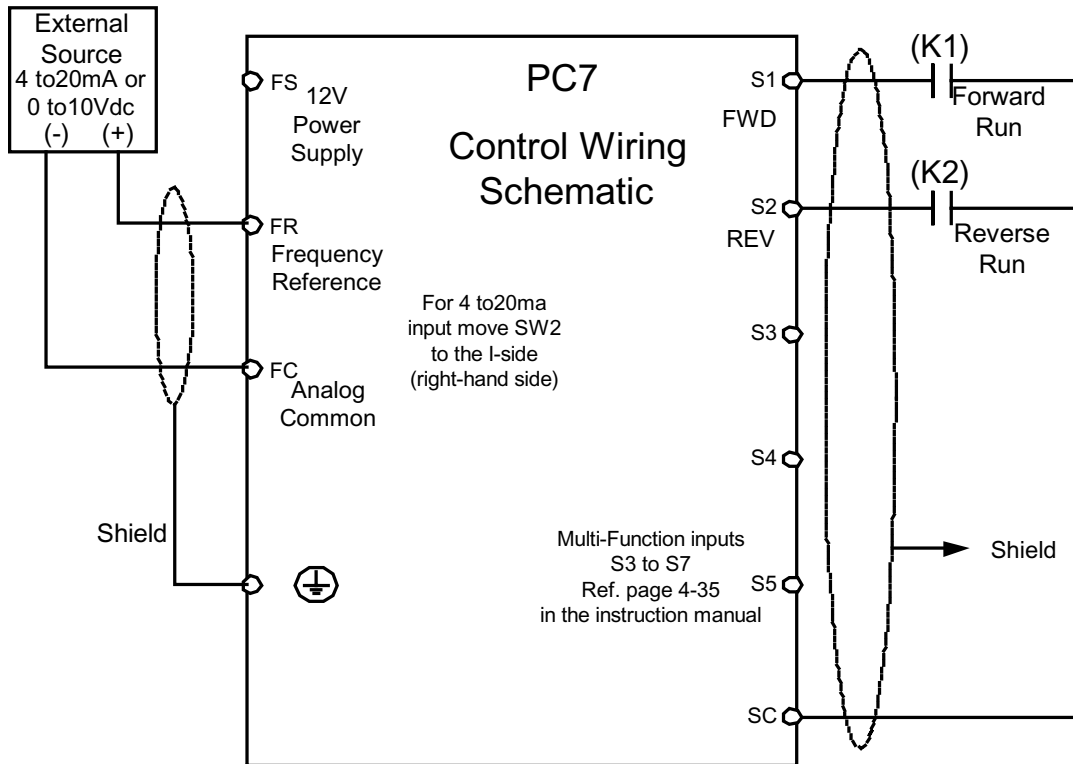

The above configuration is commonly used when the start/stop and the speed changes are supplied by a remote supply such as a PLC and relays. It can be used with a maintained switch when it is desirable to have the drive restart on restoration of power. It should not be used where safety of attending personnel might be threatened by a restart. A speed Pot. may be used in this configuration by connecting the highside to FS, the wiper to FR and the low side to FC. (5KwΩ 1/4watt)

**Table 2: Programming required for 2-wire Start/Stop and the Speed Changes via External Source**

Parameter	Display (Readout)	Description
N01	10	Reset all parameters to factory setting for a 2-wire configuration (Caution: all previous settings will be lost) Once 10 is entered, the setting will return to its factory setting of 1.
N04	2/3	2= Parameter sets terminal FR to accept a 0 to 10Vdc signal. 3= Parameter sets terminal FR to accept a 4 to 20mA signal.
N019/N020	xx.x Seconds	Acceration time and Deceleration time/ The time for stop to full speed.
N36	Motor Full Load Amps (FLA)	Enter the motor's FLA from the nameplate of the motor.

**Example 3: 3-Wire Start/Stop with External Source**

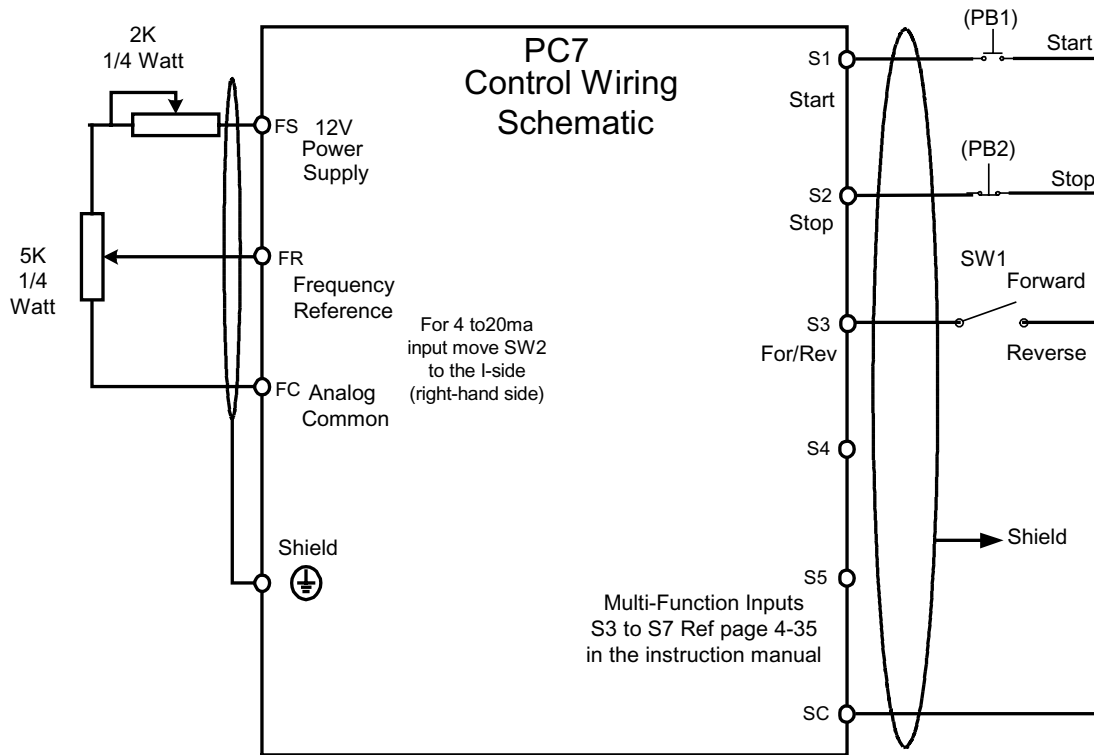

This configuration is common when an inverter has replaced a contactor in an existing application and an operator will vary the speed via the external speed pot. It is recommended that the potentiometer be between 2KWΩ and 10KWΩ and a minimum wattage of ¼ watt. The trim potentiometer is optional; it is used to eliminate any dead span on the external speed potentiometer.

**Operation**

Close push-button (PB1) momentarily while push-button (PB2) is closed and the drive will start. Pushbutton (PB1) does not need to be maintained.

Open push-button (PB2) at any time and the drive will stop. If switch SW1 is open, the drive will run in the forward direction, and when switch SW1 is closed, the unit will then change direction.

The speed changes are proportional to the input signal at terminal FR.

If the inverter is put into local mode using the LO/RE LED, the drive will behave the same as Example 1.

**Table 3: Programming needed for 3-wire Start/Stop and External Source**

Parameter	Display (readout)	Description
N01	11	Reset all parameters to factory settings for a 3-wire configuration (Caution: all previous settings will be lost ). Once 11 is entered, the setting will return to its factory setting of 1.
N04	2/3	2= Parameter sets Terminal FR to accept 0 to 10VDC signal 3= Parameter sets Terminal FR to accept 4 to 20Ma signal
N19/N20	xx.x Seconds	Acceleration Time and Deceleration Time/ The time from stop to full speed.
N36	Motor Full Load Amps (FLA)	Enter the motor's FLA from the nameplate of the motor.

## Adjusting the Trim Pot.

After the programming is complete, the trim potentiometer should be calibrated. Press the DSPL key until *Fref* led is lit. Turn the external speed potentiometer (R1) all the way up. Adjust the trim potentiometer (R2) so that the *FREF* display is just flickering between 59.9 and 60Hz. This completes the adjustment of the trim pot.

### **Terms**

**Two-Wire** – utilizes a maintained switch or relay contact, maintaining either a forward run or a reverse run command controls direction.

**Three-Wire** – utilizes a momentary button or switch. This control scheme emulates the traditional 3-wire motor starter control. A momentary closure of a normally open Run button latches the inverter in the Run mode. A momentary opening of the normally closed Stop button unlatches Run mode, bringing the inverter to a stop.

**Notes:**        Underlined words indicate a key on the keypad.  
                     *Italic words indicate an LED on the keypad.*

### **WARNING!**

*Saftronics* manufactures component parts that can be used in a wide variety of industrial applications. The selection and application of *Saftronics* products remains the responsibility of the equipment designer or end user. *Saftronics* accepts no responsibility for how it's products may be incorporated into the final design.

Under no circumstances should any *Saftronics* product be incorporated into any product or design as the exclusive or sole safety control. Without exception, all controls should be designed to dynamically fault detect and fail safe under all circumstances. All products designed to incorporate a component part manufactured by *Saftronics*, must be supplied to the end user with appropriate warnings and instructions as to the safe use and operation. Any warnings provided by *Saftronics* must be passed through to the end user.

*Saftronics* offers an express warranty only as to the quality of its products to conform to the catalog specifications. NO OTHER WARRANTY EXPRESS OR IMPLIED IS OFFERED. *Saftronics* assumes no liability for any personal injury, property damage, losses or claims, arising out of the misapplication of its products.

For more info visit [www.saftronics.com](http://www.saftronics.com)