

Basic Wiring Diagrams - Keypad Operation

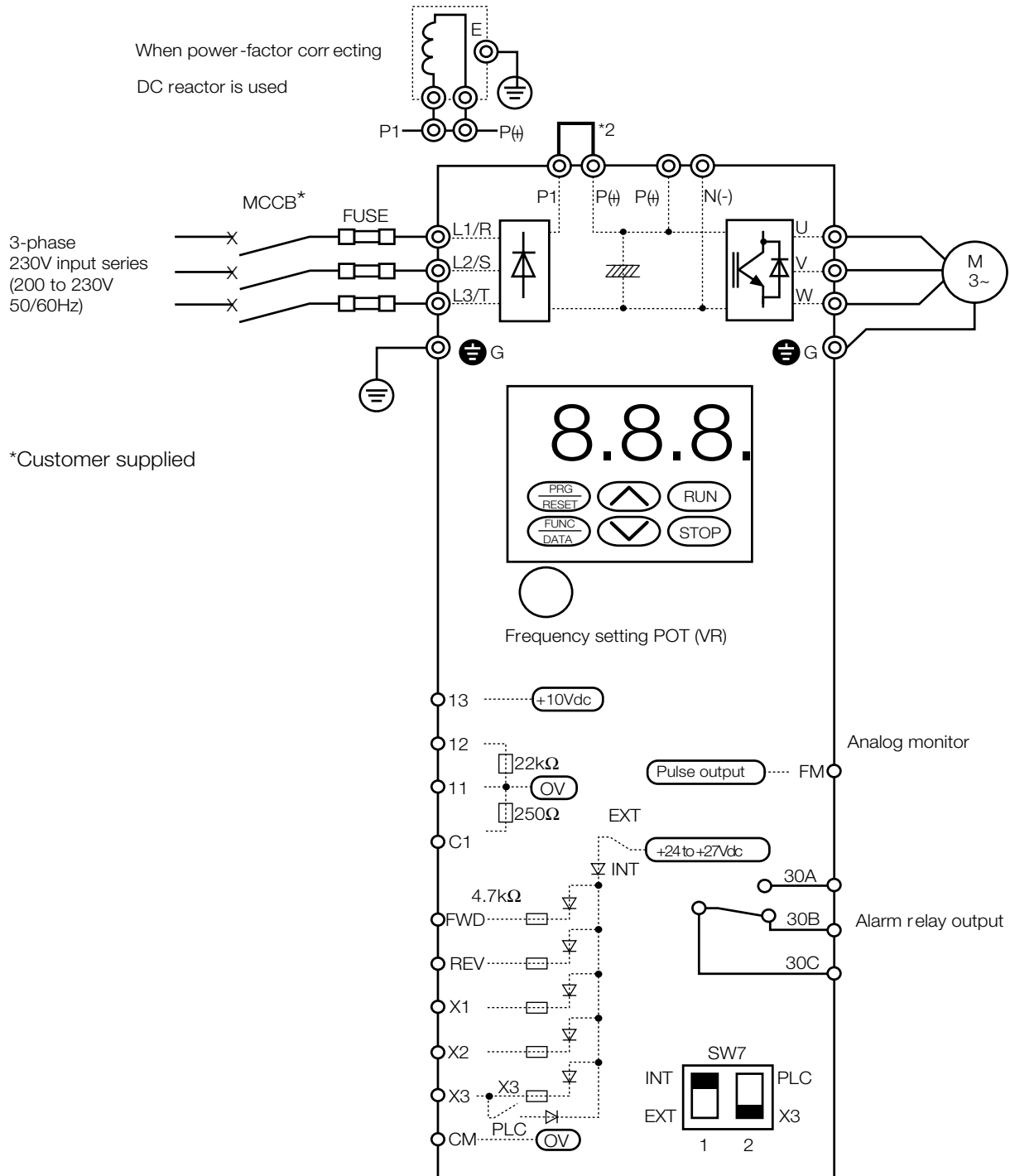

- 1) The RUN and STOP keys on the keypad panel can be used to start and stop the drive. The frequency setting, POT (VR) can be used to set the running frequency. Forward rotation is the default setting.
- 2) Remove the jumper between the P1 and P(+) terminals before connecting a DC reactor when required.
- 3) Connect the surge absorber snubber circuits in parallel with coils (such as magnetic contactors and solenoids) located near the drive.

Basic Wiring Diagrams - External Signal Operation

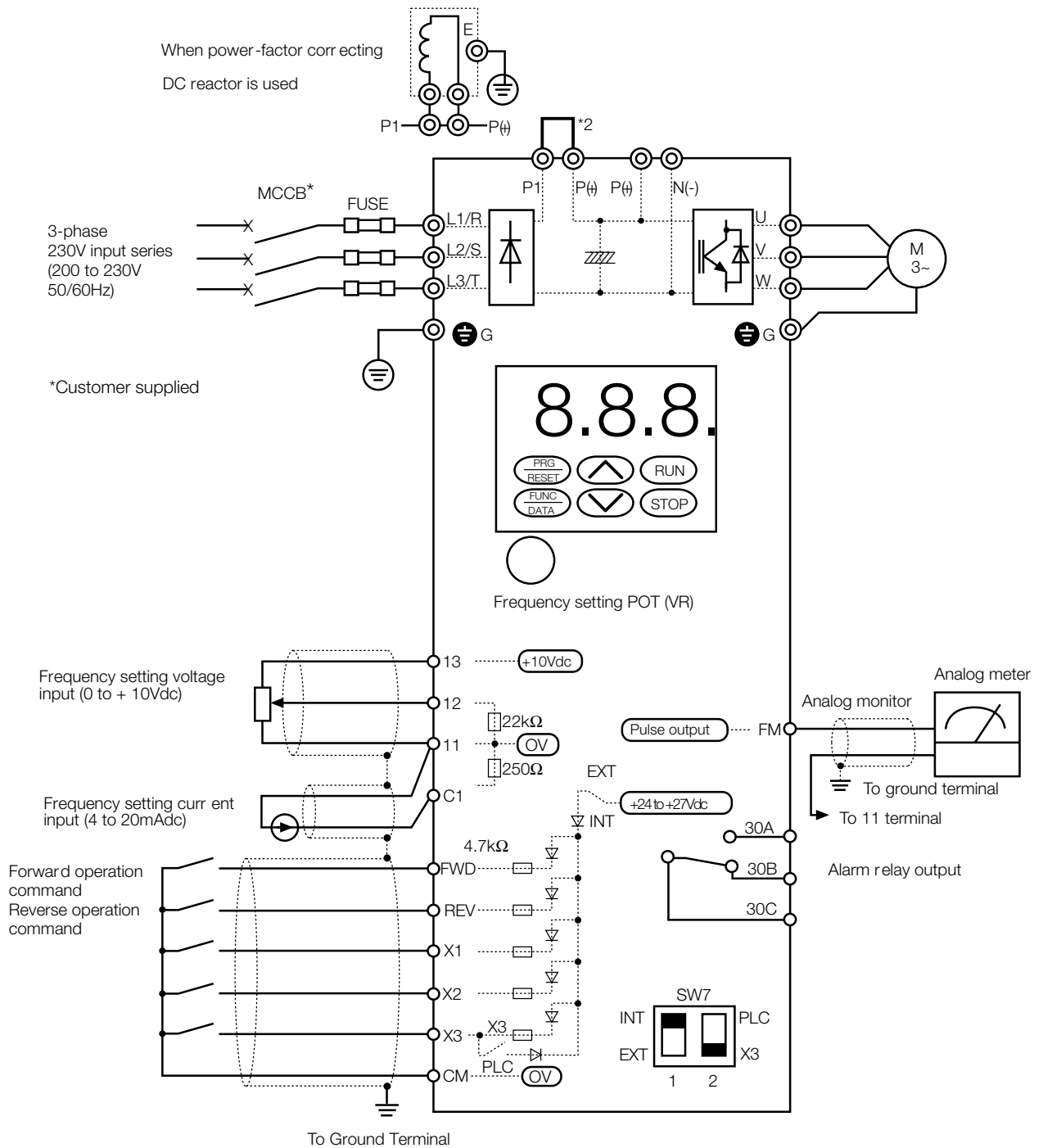

- 1) Use this connection to start, stop and set the running frequency with external signals. 0 to +10 VDC can be used when function F01 is set to 1 and 4 to 40mA can be used when function F01 is set to 2.
- 2) Remove the jumper between the P1 and P(+) terminals before connecting a DC reactor when required.
- 3) Connect the surge absorber snubber circuits in parallel to coils (such as magnetic contactors and solenoids) located near the drive.
- 4) Use twisted or shielded wire for control signals. Connect the shield to the ground terminal.