



INSTRUCTION MANUAL

DOCUMENT NO. 027 - 0170
Rev. 1.02 July 31, 2003

PGX Encoder Feedback Option Card Kit for the VG10

Part Number 100-0170-01

Saftronics, Inc.

5580 Enterprise Pkwy

Ft. Myers, FL 33905

Tel. (239) 693 - 7200

Fax (239) 639 - 2431

www.saftronics.com

SAFETY FIRST !

LETHAL VOLTAGES MAY BE PRESENT

PLEASE READ THIS MANUAL THOROUGHLY BEFORE ATTEMPTING ANY INSTALLATION, OPERATION, MAINTENANCE, OR INSPECTION. FAILURE TO FOLLOW THE RECOMMENDED PROCEDURES OR CAUTIONS IN THIS MANUAL COULD RESULT IN INJURY TO PERSONNEL AND / OR DAMAGE TO THE EQUIPMENT.

CAUTION

- 1 – CHECK THE NAME WRITTEN ON THE PRODUCT AND INSURE THAT THE PROPER PART HAS BEEN RECEIVED.
- 2 – THOROUGHLY INSPECT THE PART(S) FOR ANY DAMAGE DUE TO SHIPMENT OR HANDLING.
- 3 - THE PART(S) MAY CONTAIN CMOS CHIPS AND CAN BE DAMGED BY STATIC ELECTRICITY. HANDLING SHOULD BE IN ACCORDANCE WITH INDUSTRY STANDARDS.
- 4 - BEFORE INSTALLING THE PART(S) TURN OFF ALL POWER TO THE EQUIPMENT AND INSURE THE CHARGE INDICATOR LAMP ON THE INVERTER IS **OFF**. **LETHAL VOLTAGES ARE PRESENT**
- 5 - DO NOT CONNECT OR DISCONNECT WIRING WHILE POWER IS **ON!**
- 6 - FOLLOW GOOD STANDARD WIRING PRACTICES AND ANY APPLICABLE CODES THAT MAY APPLY.

Contents

	<i>Page</i>
1.0 Overview	3
1.1 <i>Specification summary</i>	3
1.2 <i>Kit contents</i>	3
<i>Fig. 1 Product appearance</i>	3
1.3 <i>Terminal functions</i>	4
<i>Table 1 Terminal functions</i>	4
<i>Fig. 2 Basic connection diagram</i>	4
2.0 Installation	5
2.1 <i>General</i>	5
<i>Fig. 3 30 HP or less</i>	6
<i>Fig. 4 40 HP and above</i>	7
2.2 <i>Wiring</i>	5
3.0 Programming & Operation	8
3.1 <i>Encoder requirements</i>	8
<i>Table 2 PG (Encoder) specification requirements</i>	8
3.2 <i>PG vector control</i>	9
<i>Fig. 5 Basic PG connection diagram for vector control</i>	9
<i>Table 3 Terminal functions</i>	9
3.2.1 <i>Extension Terminal functions</i>	10
<i>Table 4 Parameters related to PG vector control</i>	11
3.2.2 <i>Function code settings</i>	12
<i>A - Motor parameter settings</i>	12
<i>B - Option function settings</i>	12-13
3.2.3 <i>Further considerations</i>	14
<i>Fig. 6 Torque control diagram recommendation</i>	14
<i>Table 5 Control specification</i>	14
3.2.4 <i>Parameters that differ from standard</i>	15
<i>Table 6 : F Fundamental Functions</i>	15
<i>Table 7: E Extension Terminal Functions</i>	16-17
<i>Table 8: C Control Functions of frequency</i>	17
<i>Table 9: H High performance functions</i>	18
<i>Table 10: A Alternative motor parameters</i>	18
4.0 Additional Information	18
4.1 <i>Alarm protective function</i>	18
4.2 <i>I/O Check</i>	18

PGX Encoder Feedback Option Card for the VG10

P/N 100 – 0170 – 01

1.0 OVERVIEW

The **100 – 0170 – 01** Option Card is designed for use with the **Saftronics VG10** Inverter series. It provides an encoder interface for closed loop vector control of the **VG10** and can supply +5 VDC **or** +12 VDC to the encoder. The encoder signal direction may be set with two on board jumpers.

1.1 Specification Summary

The card is designed to interface with the following encoder specifications:

- No. of output pulses 20 to 3000 / Rev. A /B phase (inc.)
- Maximum response frequency 100 KHz
- Pulse interface method RS422

Encoder supply voltage - +5 VDC @ 200 mA. (max.) or +12 VDC @ 300 mA (max.)
(Note: Both supplies **cannot** be used at the same time)

Encoder direction - Jumpers D1 & D2 set the signal direction. When in the normal position, (factory default) the encoder signals are set for the motor rotation to be counterclockwise when looking at the motor shaft.

Environmental - See VG10 Manual

1.2 Kit Includes

- (1) 100-0170-01 OPTION CARD
- (3) P/N 026-6008 SUPPORTS
- (1) P/N 020-0212 M3-6 SCREW

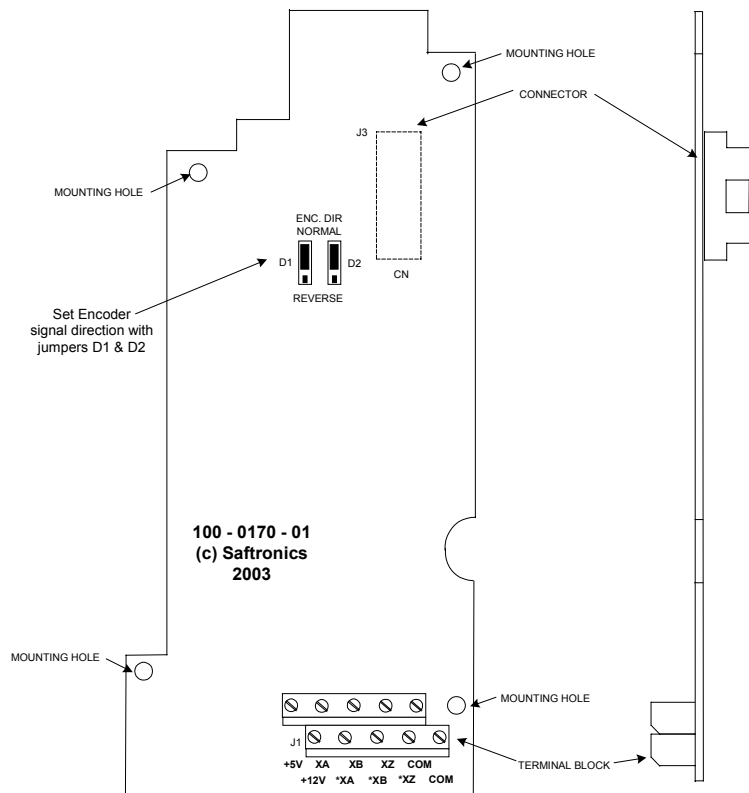

Fig. 1 Product Appearance

1.3 Terminal functions

Table 1 Terminal Functions

Terminals	Function
+12 VDC	Power supply for Encoder (Max. 300 mA.)
+5 VDC	Power supply for Encoder (Max. 200mA.)
COM	Power Supply common
XA	Input from + A phase signal of encoder
*XA	Input from - A phase signal of encoder
XB	Input from + B phase signal of encoder
*XB	Input from - B phase signal of encoder
XZ	Input from + Z marker signal
*XZ	Input from - Z marker signal

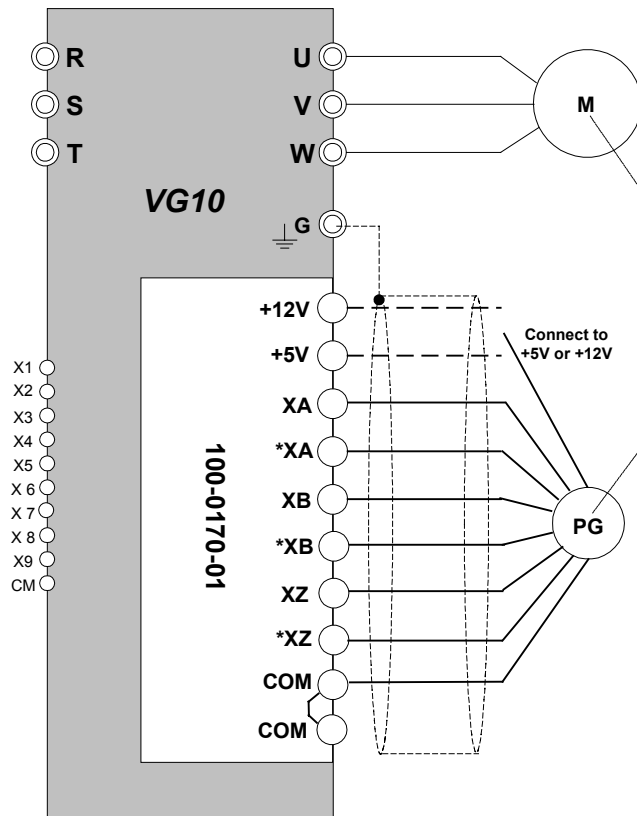

Fig. 2 Basic Connection Diagram

2.0 INSTALLATION

Please read this manual in its' entirety before attempting any installation!

2.1 General

Turn off all power to the equipment being worked on before attempting any installation. Fig. 1 shows the appearance of the option card. Ensure that the proper option card has been received along with the accessories listed and that no damage has occurred to the parts.

Following **Fig. 3** or **Fig. 4**, install the option card for the **VG10** Inverter HP ranges listed. Using good standard practices, and in accordance with applicable codes, make the connections to the option card in accordance with **Fig. 2**, Basic Wiring Diagram, and the application requirements. Use the following wiring guidelines to insure optimum performance.

2.2 Wiring

CAUTION

•Check the wiring before operating the drive. Improper wiring may cause unexpected drive operation or device operation. **There is a risk of accident or injury.**

Wiring the Option Card

- Use shielded cable for wiring the drive option, keeping the wire length to within 328 feet (100m).
- Connect the sheath of the shielded cable to the terminal **G** of drive only, and leave the other end open.
- Run the option wiring at least 4" (10 cm) from the main circuit wiring of the drive main unit and other power cables to avoid abnormal operation due to noise. **Do not** run the option wiring in the same electrical duct with other power cables.

Terminal Connection on Option Card

The wire size range that the option card connection terminal(s) can accommodate, is AWG: 16-26.

Referring to the figure below, strip the wire back about 1/4 " (6 mm) and make the connection to the terminals by inserting wire into the upper side of the metal bracket on the terminal block, and tighten the screw.

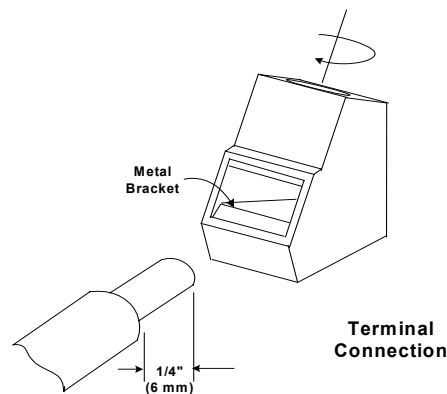

VG10 30HP or less

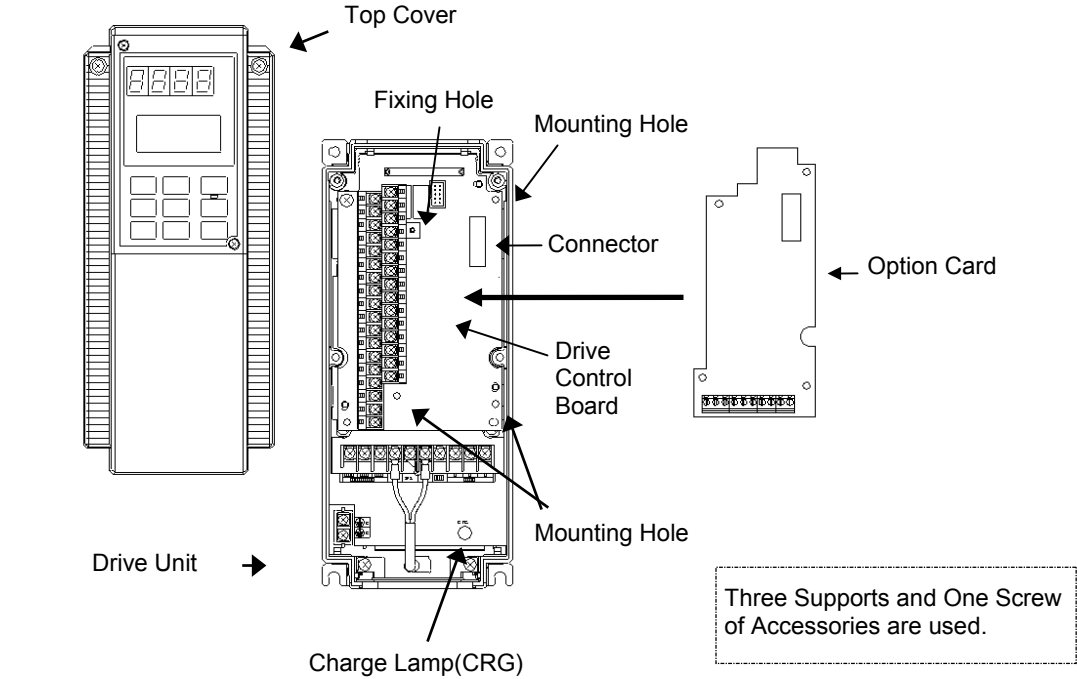

Step 1

Remove the top cover, and insert the accessory supports into the three mounting holes on the Drive control Board.

Step 2

Set the supports inserted in step 1 on the option card, and insert the Drive control board connector to the option card connector. After that, check that you can see the pins of the supports on the option card.

Step 3

Insert and tighten the screws (M3 x 6) in the fixing holes to secure the option card.

Step 4

Wire the option according to the basic connection diagram.

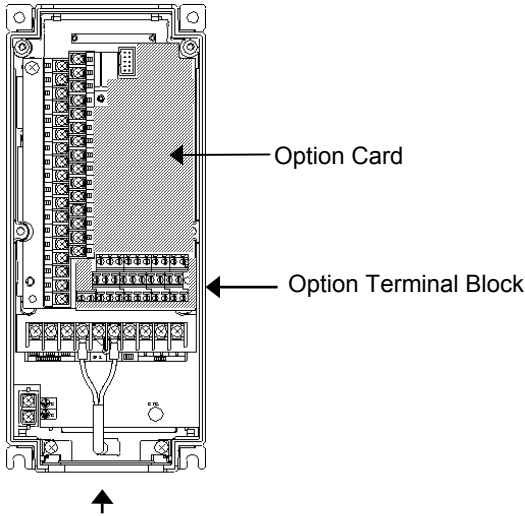
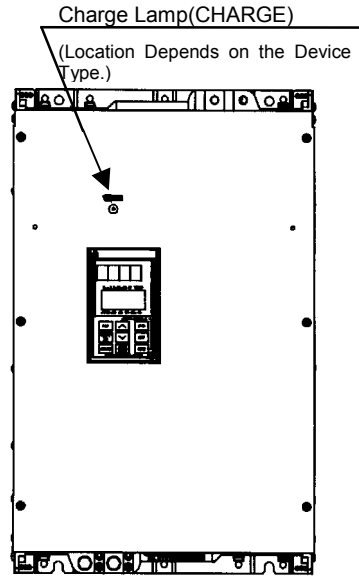
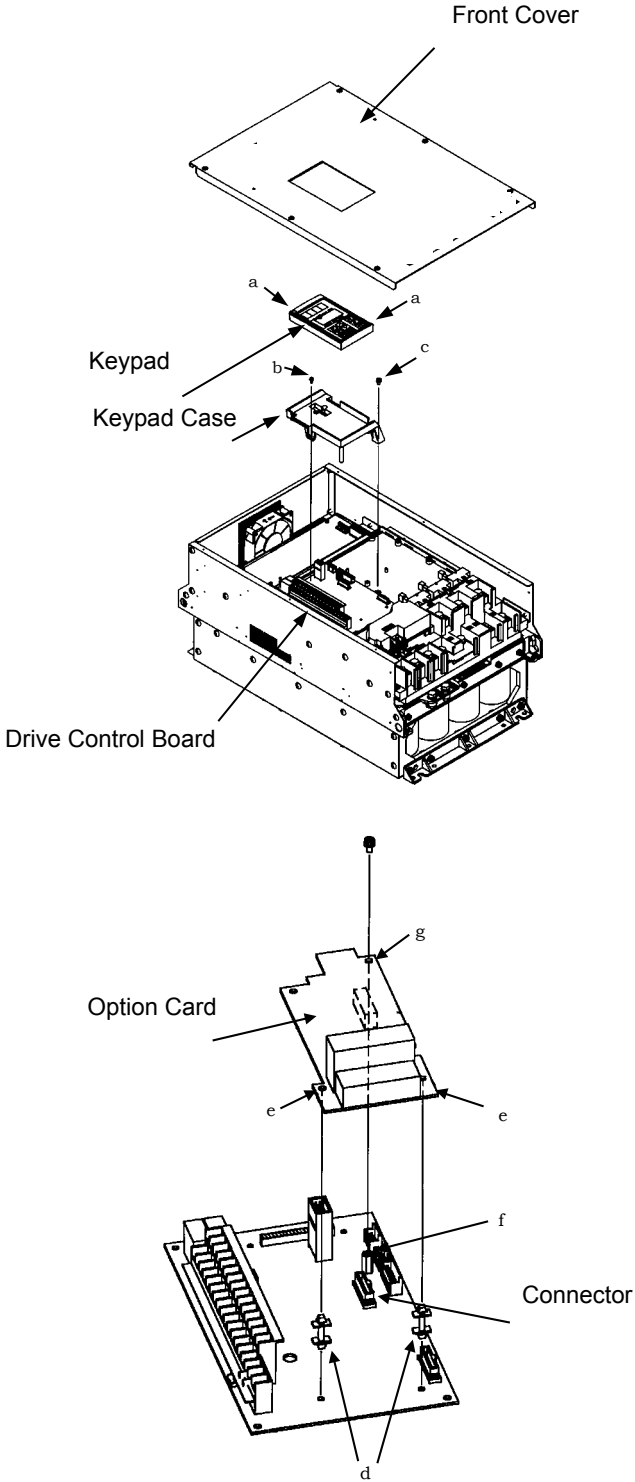

Fig. 3 30 HP or Less

VG10 40 HP and above

Two Supports and One Screw of Accessories are used.



Step 1

Remove the front cover and loosen the two M3 screws (a) to remove the keypad panel.

Step 2

Remove one M3 screw (b) and one M4 screw (c) to remove the keypad panel case.

Step 3

Insert the two accessory supports (d) into the drive control board.

Step 4

Insert the two supports (d) into the holes (e) on the option card. Align the support (f) with the hole (g) on the option card, then and insert one connector.

Step 5

Insert and tighten the accessory screws (M3 x 6) at (f) and (g) to secure the option card.

Step 6

Replace the keypad panel, case, keypad, and the front cover. then reassemble the drive.

Fig. 4 40 HP and Above

3.0 PROGRAMMING & OPERATION_

After the option card has been PROPERLY INSTALLED, TURN POWER ON and proceed with the following programming and set-up. DO NOT ATTEMPT TO OPERATE THE DRIVE UNTIL ALL OF THE APPLICABLE PROGRAMMING HAS BEEN COMPLETED.

3.1 Encoder Requirements

The following sections describe the implementation of the **PG** or encoder that is used with the **VG10**.

Table 2 The PG (Encoder) specification requirements to interface to the VG10 drive option card.

Item		Specifications
Applicable PG	Output Pulse	100 to 3000P/R Phase A or Phase B (incremental)
	PG Power Supply	+5 VDC / 200 mA (max.) or +12 VDC / 300 mA (max.)
	Maximum Response Frequency	100kHz
	Pulse Output System	RS422
PG Power Supply	Internal Power Supply	+ 5VDC +/- 1% @ 200 mA max. or (see note) +12VDC +/- 1% @ 300 mA max.
Jumpers D1 & D2	Sets the direction of the Encoder signals	Normal : Motor direction is counterclockwise looking at motor shaft Reverse : Motor direction is clockwise looking at motor shaft

Note: Either the +5V or +12V supply may be used but not both

PG (Encoder) Installation and Signal

In accordance with the diagram below, **forward** motor running is considered counterclockwise rotation looking at the motor shaft. In **forward** running, phase B signal leads phase A by 90 degrees. In reverse running, phase A signal leads phase B by 90 degrees. The on board jumpers **D1** and **D2**, (see Fig.1) are factory set (normal) for **forward** motor running. If the motor is connected for **reverse** operation, then jumpers **D1** and **D2** must be set for reverse.

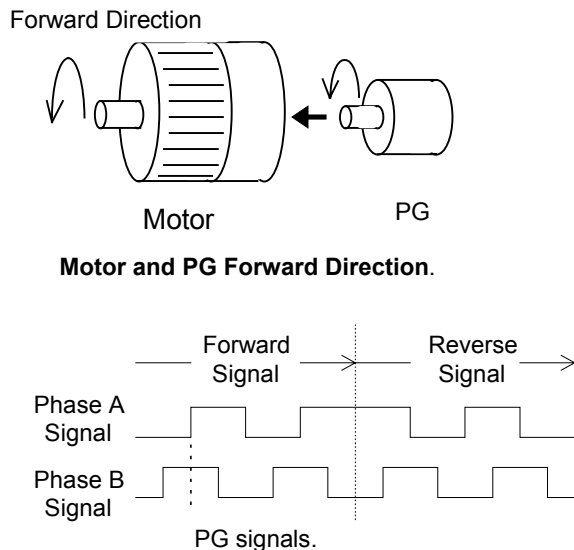

3.2 PG Vector Control

The PG feedback signals are used by the closed loop vector control.

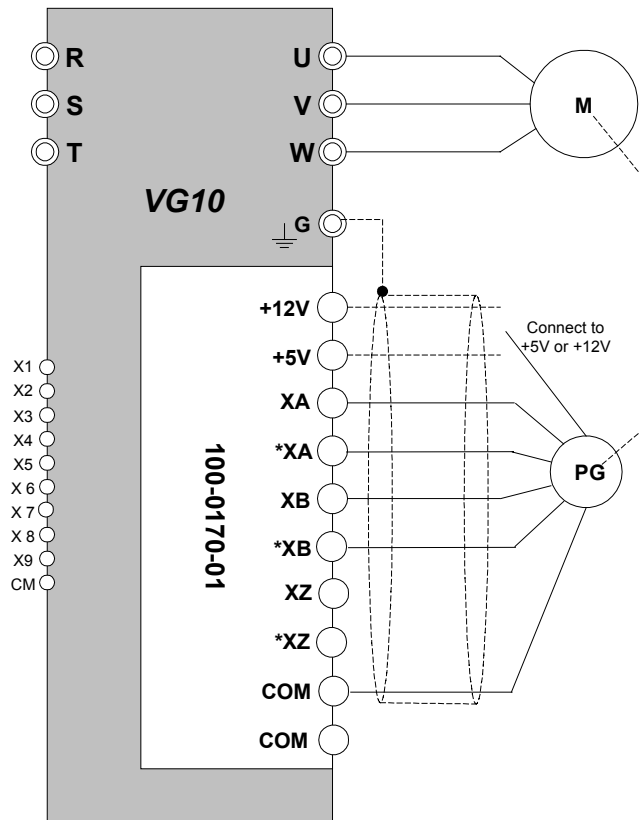

Fig 5 Basic PG Connection Diagram

Table 3 Terminal functions When PG Vector Control Used.

Terminal Symbol	Terminal Name	Function	
Option Side	+5V	PG Power Supply Output (see note)	Outputs power to PG.
	+12V	PG Power Supply Output (see note)	Outputs power to PG.
	COM	PG Power Supply Common	Common for the +5V or +12V
	XA	Input of feedback PG phase A+ Pulse	Connects feedback PG phase A + signal
	*XA	Input of feedback PG phase A - Pulse	Connects feedback PG phase A - signal
	XB	Input of Feedback PG phase B+ Pulse	Connects feedback PG phase B+ signal.
*XB	Input of Feedback PG Phase B- Pulse	Connects feedback PG phase B- signal.	
Drive Side	X Terminal	See Terminal Extension Functions for Vector Control	

Note: Either the +5V or +12V supply may be used but not both

3.2.1 Terminal Extension Functions For Vector Control (Ref. Table 7)

1 - Valid PG Feedback Command

When **E01** to **E09** is set to **27: SY-PG enable (PG/Hz)**, the **PG** option (speed feedback control) can be canceled with corresponding digital input terminals from **X1** to **X9** (effective when the unit's digit of ***o01** is set to **1, PG Vector Control**). Note that this ON or OFF command is not effective during operation and becomes effective after the drive stops. When terminals **X1** to **X9** are not allocated for **PG/Hz**, speed feedback control is always effective.

X Terminal	Function
ON	Closed loop control
OFF	Open loop control

2- Zero Speed Command Function

Zero speed command is to maintain torque at zero speed, when PG vector control is used. When **E01** to **E02** is set to **29: ZERO speed command (ZERO)**, zero speed torque can be used with corresponding digital input terminals **X1** to **X9**. (effective when the unit's digit of ***o01** is set to **1, PG Vector Control**).

X Terminal	Function
ON	zero speed command enabled
OFF	zero speed command disabled

3 - Pre-excitation Command Function

The pre-excitation command function is to improve starting characteristics by exciting the motor before running. The pre-excitation function is canceled while the motor is running. When **E01** to **E09** is set to **32: Pre-excitation command (EXITE)**, excitation can be controlled with corresponding digital input terminals **X1** to **X.9** (effective when the unit's digit of ***o01** is set to **1, PG Vector Control**). Note that the DC braking function takes precedence over pre-excitation function. You should set the sequence so that pre-excitation starts before driving a motor and that pre-excitation stops before stopping a motor.

X Terminal	Function
ON	pre-excitation command enabled
OFF	pre-excitation command disabled

* See Function Code Settings: Section 3.2.2 B – Option Function Settings
Also refer to the **VG10** manual for further information

Table 4 The parameters related to PG vector control.

Func No.	Name	Setting Range	Unit	Min. Unit	Factory Setting	Change during operation
F03	Maximum frequency 1	50 to 400Hz	Hz	1	60	N
F04	Base frequency 1	25 to 400Hz	Hz	1	50	N
F05	Rated voltage 1	0V: Outputs voltage proportion to input voltage. 80 to 240V : 230V class 320 to 480V : 460V class	V	1	230/460	N
F40	Torque limiter 1 (Driving) (Braking)	20 to 200% ,999% (No limit)	%	1	999	Y
F41		0% (Automatic deceleration control) 20 to 150% ,999% (No limit)	%	1	999	Y
E16	Torque limiter 2 (Driving) (Braking)	20 to 200% ,999% (No limit)	%	1	999	Y
E17		0% (Automatic deceleration control), 20 to 150% ,999% (No limit)	%	1	999	Y
E01 to E09	Terminal X Function	27: SY/PG control section	-	-	-	N
		29: ZERO speed command sel.	-	-	-	N
		32: Pre-excitation command	-	-	-	N
P01	Motor 1 (Number of poles)	2 to 14	Pole	2	4	N
P02	(Capacity)	30HP or less :0.01 to 60HP	kW	0.01	Typical value of standard motor	N
P03		40HP or more :0.01 to 600HP	A	0.01		
P05	(Rated current)	0.00 to 2000A	A	0.01	Typical value of standard motor	N
P06	(On-line tuning)	0 : Inactive 1 : Active	-	-	0	N
P07	(No-load current)	0.00 to 2000A	A	0.01	Typical value of standard motor	N
P08		(%R1)	0.00 to 50.00%	%	0.01	Typical value of standard motor
P09	(%X)	0.00 to 50.00%	%	0.01	Typical value of standard motor	Y
P09	(Slip compensation control 1)	0.00 to 5.00Hz	Hz	0.01	Typical value of standard motor	Y
H18	Torque control	0, 1, 2	-	-	0	N
H28	Droop control	-9.9 to 0.0Hz	Hz	0.1	0.0	Y
o01	Speed command system / automatic speed control system	00 ,01 ,10 ,11 ,20 ,21	-	-	00	N
o02	Time constant of PG vector and speed command filter	0.000 to 5.000	s	0.001	0.02	Y
o03	Number of feedback PG pulses	20 to 3000	p	1	1024	N
o04	Constant P of feedback speed controller	0.01 to 200.00	Times	0.01	10.00	Y
o05	Constant I of feedback speed controller	0.000 to 5.000	s	0.001	0.100	Y
o06	Time constant of feedback speed detection filter	0.000 to 5.000	s	0.001	0.005	Y
o07	Feedback pulse correction coefficient 1	1 to 10000	-	1	1	N
o08	Feedback pulse correction coefficient 2	1 to 10000	-	1	1	N

3.2.2 Function Code Settings

WARNING
•Check and adjust parameters before operation. Improper parameters may cause an unexpected operation for some devices. There is a risk of accident.

To perform PG closed loop vector control, the function codes below must be set. Set the function codes according to the procedure below. Operating the drive without setting function codes may cause unexpected drive or device operation.

A - Motor Parameter Settings:

Setting function codes F, P, and A

Set function codes *F03, F04, F05, P01, P02, P03, P06, P07, P08, and P09 according to the VG10 Instruction Manual.

When using a second motor, set function codes A01, A02, A03, A10, A11, A12, A15, A16, A17, and A18 according to the VG10 instruction manual.

- * When the maximum frequency (F03) is changed after constant P and constant I adjustment, constant P and constant I must be readjusted. Set F03 before adjusting both constant P and constant I.

B - Option Function Settings:

Function code o01: Sets the speed command and automatic speed control system. The unit's digit of o01 selects the speed command system. The ten's digit of o01 for this option card is always set to zero.

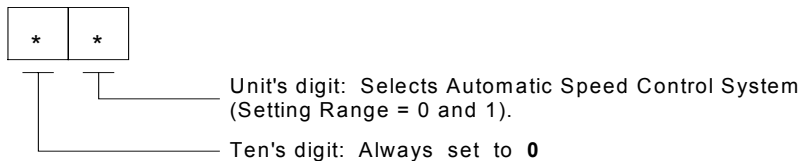

Function code		Function	
o01	Unit's Digit	0	Without speed feedback control
		1	PG vector control
	Ten's Digit	0	Always Set to 0
		1	
		2	

Function code o02: Sets the time constants of primary delay filter for the speed setting. This code is used to suppress overshoot when speed commands are changed.

Function code o03: Sets the number of feedback PG pulses.

Function code o04: Sets constant P of the feedback speed controller. (*1)

Function code o05: Sets constant I of the feedback speed controller. (*1)

The transfer function of the speed controller is expressed as follows:

$$\tau^* = k_p \left(1 + \frac{1}{sT_I} \right) \times \varepsilon$$

Kp : Constant P

T_I : Constant I

τ* : Torque command

ε : Speed deviation

When speed deviation ε = 100%, Constant P (for torque command τ* = 100%) is assumed to be 1.

Function code o06: Sets the time constants of primary delay filter for the speed detection value. This code is used to suppress the large ripple in the speed detection signal. Set function code **o07** and **o08** for a motor equipped with speed reducer.

Function code o07: Sets pulse compensation coefficient 1. (*2)

Function code o08: Sets pulse compensation coefficient 2. (*2)

(*1) Function codes **o04** and **o05** must be readjusted when the value of function code **F03** is changed.

(*2) Set a value of **o08 / o07** to 1 or more. Any value less than 1 is treated as 1.

Reference:

PG Vector Control Setting Procedure

Set function codes **o02:** 0.02 (s), **o04:** 10 (times), **o05:** 0.1 (s), and **o06:** 0.005 (s). See the setting procedure for constants **P (o04)** and **I (o05)** below to adjust stability and response. Adjusting constants with function codes **o02** (time constant of speed command filter) and **o06** (time constant of feedback speed filter) can also improve stability and response.

Constant P (o04)

Constant **P (o04)** is a parameter used to determine response speed for any deviation in proportion operation. Specifying a larger value for constant **P** enables a quicker response. Specifying a value that is too large results in vibrating response. Specifying a smaller value for constant **P** slows the response.

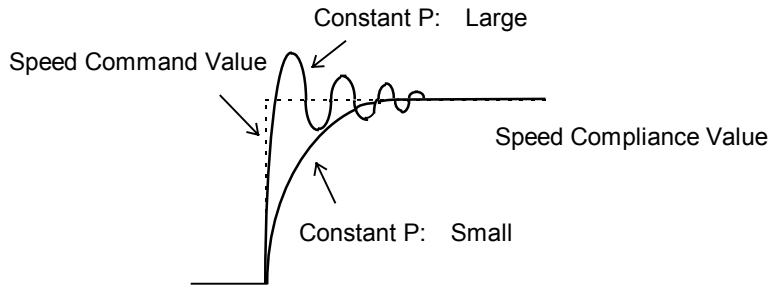

Constant I (o05)

Specifying a larger value for constant **I (o05)** slows the response and weakens the reaction to external force. Specifying a smaller value for constant **I** enables a quicker response. Specifying a value that is too small results in unstable (vibrating) response. Vibration in a larger cycle than constant **I** can be suppressed.

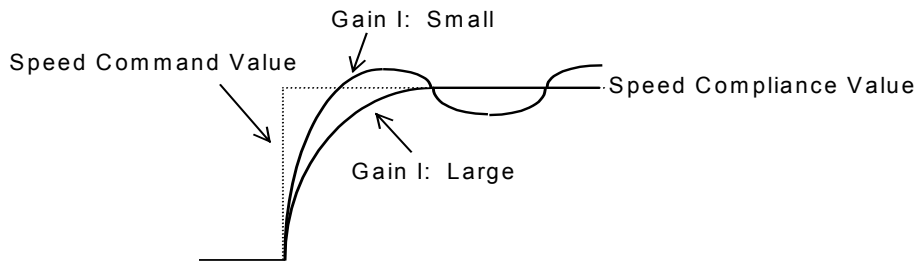

3.2.3.Further Considerations

Carrier Frequency

Set the carrier frequency (**F26**) to more than 5(kHz) to suppress hunting when using **PG** closed loop vector control.

Electronic Thermal Overload Relay Protection

Prevent motor overheating by using the electronic thermal overload relay function when **PG** closed loop vector control is used. See the **VG10** instruction manual for details of the electronic thermal overload relay setup.

When Torque Control Used

When **PG** closed loop vector control and torque control are used concurrently, a line power interruption may not be detected depending on the load state. In this case, input the line power interruption signal at the **BX** terminal and stop the drive.

Fig. 6 shows an example of connection.

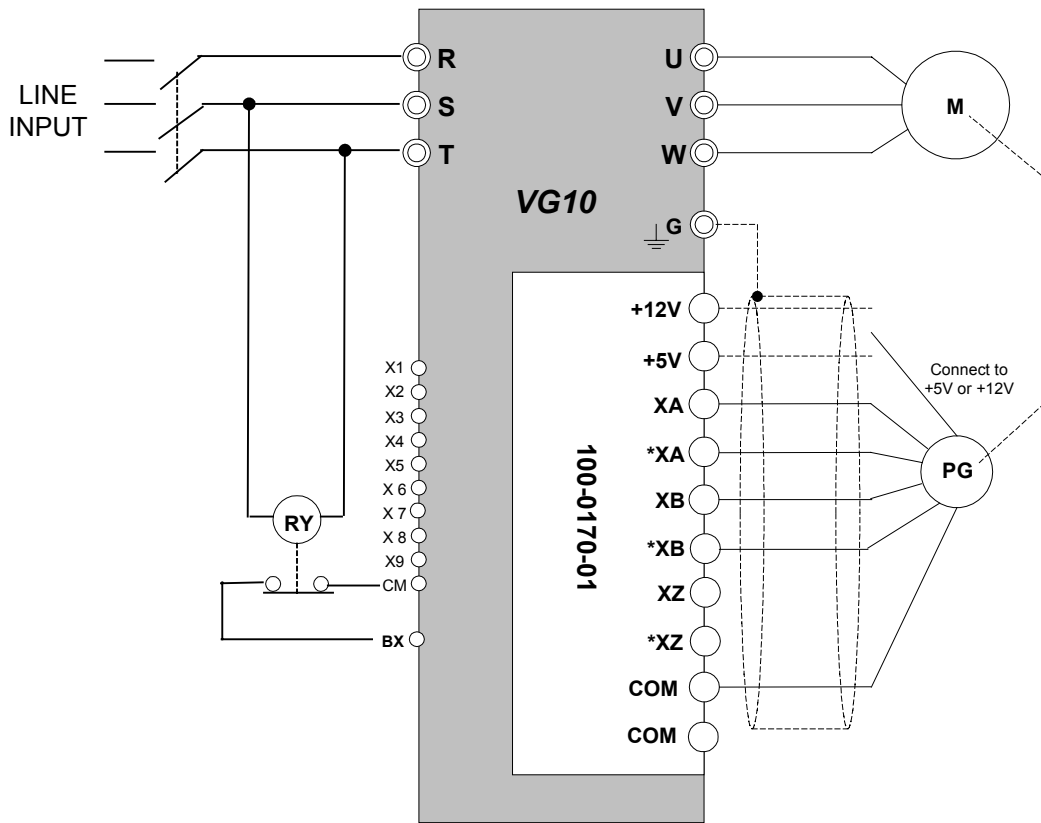

Fig 6 Recommended When Torque Control is Used

Control Specifications are listed in Table 5, when **PG** closed loop vector control is used.

Table 5 Control Specifications.

Item	Control Specifications
Speed Control Range	3 to 3600 [rpm] (for 4-pole motor)
Speed Control Accuracy	±0.02%
Starting Torque	150% / zero-speed (at ZERO signal ON) short time
Maximum Number of Input Pulses	100(kp/s)

3.2.4 The functions that differ from the standard specifications are listed as follows, when PG vector control is used.

Table 6 F : Fundamental Functions

Func.	Function Name	LCD Display	Setting Range	Units	Spec. when PG Vector Mode
F03	Max. Frequency 1	F03 MAX_Hz-1	50 to 400Hz	Hz.	Note: 120hz limit in PG Vector Mode.
F05	Rated Voltage 1	F05 Rated_V-1	0V: Output Voltage	V.	Set to 0V for AVR operation
	(at base frequency)		proportion to input voltage		
F06	Max. Voltage 1	F06 Max V-1	80 to 240V (230 unit)	V.	Invalid in Vector Mode
	(at Max. Freq. 1)		320 to 480V (460 unit)		
F09	Torque Boost 1	F09 TRQ Boost 1	0 to 20	-	Invalid in Vector Mode
F15	Freq. Limit(High)	F15 H LIMITER	0 to 400Hz.	Hz.	Note: 120hz limit in PG Vector Mode.
F20	DCBrake Start Freq.	F20 DC BRK Hz	0 to 60Hz.	Hz.	DC inj. Braking operates when the run command is off and the output frequency is equal to or less than the start freq.
F21	DC Braking Level	F21 DC BRK LVL	0 to 100%	%	
F22	DC Braking Time	F22 DC BRK t	0 to 30 Seconds	S	
F31	FMA Function	F31 FMA FUNC	0 = Output Freq.(before slip)		0 = ASR setting Value
			1 = Output Freq.(after slip)		1 = Output Freq.
			2 = Output Current		2 = Output Current
			3 = Output Voltage		3 = Output Voltage
			4 = Output Torque		4 = ASR output or torque command
			5 = Load Factor		5 = ASR output or torque command
			6 = Input Power		6 = Input Power
			7 = PID feedback		7 = PID feedback
			8 = PG feedback		8 = Speed Detection Value
F35	FMP Function	F35 FMP FUNC	0 = Output Freq.(before slip)		0 = ASR setting Value
			1 = Output Freq.(after slip)		1 = Output Freq.
			2 = Output Current		2 = Output Current
			3 = Output Voltage		3 = Output Voltage
			4 = Output Torque		4 = ASR output or torque command
			5 = Load Factor		5 = ASR output or torque command
			6 = Input Power		6 = Input Power
			7 = PID feedback		7 = PID feedback
			8 = PG feedback		8 = Speed Detection Value
F40	TRQ Limiter (DRV)	F40 DRV TRQ 1	20 to 200% 999 disable	%	200% when 999 is set
F41	TRQ Limiter (BRK)	F41 BRK TRQ 1	20 to 200% 999 disable	%	200% when 999 is set
F42	TRQ Vector Control	F42TRQVECTOR	0 - 1		set to 1 for PG Vector Mode

Table 7 E: Extension Terminal Functions

Func.	Function Name	LCD Display	Setting Range	Spec. when PG. Vector Mode
E01	X1 Term. Function	E01 X1 FUNC	0 = Multi-step Freq.	0 = Multi-step Freq.
E02	X2 Term. Function	E02 X2 FUNC	1 = Multi-step Freq.	1 = Multi-step Freq.
E03	X3 Term. Function	E03 X3 FUNC	2 = Multi-step Freq.	2 = Multi-step Freq.
E04	X4 Term. Function	E04 X4 FUNC	3 = Multi-step Freq.	3 = Multi-step Freq.
E05	X5 Term. Function	E05 X5 FUNC	4= ACC/DEC time 1	4= ACC/DEC time 1
E06	X6 Term. Function	E06 X6 FUNC	5= ACC/DEC time 2	5= ACC/DEC time 2
E07	X7 Term. Function	E07 X7 FUNC	6= 3-wire Start/Stop	6= 3-wire Start/Stop
E08	X8 Term. Function	E08 X8 FUNC	7= Coast to Stop	7= Coast to Stop
E09	X9 Term. Function	E09 X9 FUNC	8= Alarm reset	8= Alarm reset
			9= Trip Command(OH2)	9= Trip Command(OH2)
			10= Jog Operation	10= Jog Operation
			11= Freq. 1 to Freq. 2	11= Freq. 1 to Freq. 2
			12= Motor2/Motor1	12= Motor2/Motor1
			13= DC Brake Command	13= DC Brake Command
			14= Trq limiter1/Limiter2	14= Trq limiter1/Limiter2
			15= Switch Line to Drive/50Hz	15= detects motor speed/switch to line
			16= Switch Line to Drive/60Hz	16= detects motor speed/switch to line
			17= Up Command	17= Up Command
			18= Down Command	18= Down Command
			19= Disable changing Func,	19= Disable changing Func,
			20= PID Cancel	20= PID Cancel
			21= Inverse Mode Select	21= Inverse Mode Select
			22= Interlock	22= Interlock
			23= TRQ Control Cancel	23= TRQ Control Cancel
			24= Serial Link enable	24= Serial Link enable
			25= Universal DI	25= Universal DI
			26= Pickup Start Mode	26= Pickup Start Mode
			27= SY-PG enable	27= Cancel Speed Feedback control
			29= Zero Speed Command	29= Zero Speed Comm.(PG. Vector)
			30= Alarm Stop	30= Alarm Stop
			31= Alarm Stop dec4	31= Alarm Stop dec4
			32= Pre-exciting Command	32= Pre-exciting Command(PG. vector)

Table 7 E : Extension Terminal Functions (con't)

E20	Y1Term. Function	E20 Y1 FUNC	0 = Drive Running	0 = Drive Running
E21	Y2Term. Function	E21 Y2 FUNC	1= Freq. arrival Det.	1= Freq. arrival Det.
E22	Y3Term. Function	E22 Y3 FUNC	2= Freq. Level Det.	2= Freq. Level Det.
E23	Y4Term. Function	E23 Y4 FUNC	3= Under-voltage Det.	3= Under-voltage Det.
E24	Y5a/Y5cTerm. Func	E24 Y5 FUNC	4= TRQ Polarity(BRK/DRV)	4= ASR Output
			5= TRQ Limiting	5= ASR output limit
			6= Auto-Restarting	6= Auto-Restarting
			7= Overload early Warning	7= Overload early Warning
			8= Keypad Operation	8= Keypad Operation
			9= Drive Stopping	9= Drive Stopping
			10= Ready Output	10= Ready Output
			11= Line/INV Changeover	11= Line/INV Changeover
			12= Line/INV Changeover	12= Line/INV Changeover
			13= Line/INV Changeover	13= Line/INV Changeover
			14= Motor 2/Motor 1	14= Motor 2/Motor 1
			15= Terminal AX Function	15= Terminal AX Function
			16= Patt. Oper. Completed	16= Patt. Oper. Completed
			17= Patt. Oper Cycle	17= Patt. Oper Cycle
			18= Patt. Stage 1	18= Patt. Stage 1
			19= Patt. Stage 2	19= Patt. Stage 2
			20= Patt. Stage 4	20= Patt. Stage 4
			21= Alarm Indication 1	21= Alarm Indication 1
			22= Alarm Indication 2	22= Alarm Indication 2
			23= Alarm Indication 4	23= Alarm Indication 4
			24= Alarm Indication 8	24= Alarm Indication 8
			25= Fan Operating Signal	25= Fan Operating Signal
			26= Auto-resetting	26= Auto-resetting
E30	FAR function(HYS)	E30 FAR HYSTR	0.0 to 10Hz	According to Actual Motor Speed
E31	FDT Signal Level	E31FDT1 LEVEL	0 to 400Hz	According to Actual Motor Speed
E32	FDT Hystersis	E32 FDT HYSTR	0.0 to 300Hz	According to Actual Motor Speed
E40	Display Coe. A	E40 COEF A		Coefficient for Motor Speed
E41	Display Coe. B	E41 COEF B		Coefficient for Motor Speed

Table 8 C: Control Functions of Frequency

Func.	Function Name	LCD Display	Setting Range	Units	Spec. when PG. Vector Mode
C05	Multi-step Freq.	C05 MULTI HZ- 1	0 to 400Hz	Hz	Limit 120hz with PG. feedback
C20	Jog Frequency	C20 JOG HZ	0 to 400Hz	Hz	Limit 120hz with PG. feedback

Table 9 H : High Performance Functions

Func.	Function Name	LCD Display	Setting Range	Units	Spec. when PG. Vector Mode
H09	Start Mode	H09 START MOD	0 : Inactive		0 : Inactive(active at auto-restart)
			1 : Active		1 : Active
			2 : Active		2 : Active
H10	Energy Saving	H10 ENERGY SA	0 : Inactive		Invalid in PG. Vector Mode
			1 : Active		

Table 10 A : Alternative Motor Parameters

Func.	Function Name	LCD Display	Setting Range	Units	Spec. when PG. Vector Mode
A01	Max. Frequency 2	A01 MAX_Hz-2	50 to 400Hz	Hz.	Note: 120hz limit in PG. Vector Mode.
A02	Base Frequency 2	A02 BASE Hz-2	25 to 400Hz	Hz.	Note: 120hz limit in PG. Vector Mode.
A03	Rated Voltage 2 (at base frequency)	A03 Rated_V-2	0V: Output Voltage proportion to input voltage	V.	Set to 0V for AVR operation
A04	Max. Voltage 2	A04 Max V-2	80 to 240V (230 unit)	V.	Invalid in Vector Mode
	(at Max. Freq. 2)		320 to 480V (460 unit)		
A05	Torque Boost 2	A05 TRQ Boost 2	0 to 20	-	Invalid in Vector Mode

4.0 Additional Information

4.1 Alarm protective function

When the drive protective function is activated, the drive is immediately tripped, an alarm is displayed on the keypad panel LED, and the motor coasts to a stop. If this protective function is activated, remove the cause of the trip, then restart the drive. **Do not** use an external sequence to automatically reset the alarm. See table below about tripping related to this option card. For other sources of tripping see “**protective operations**” in the **VG10** instruction manual.

Trip Display	30ABC	Cause of Trip
OS	ON	1 – Overspeed error : Displays an error if detection speed exceeds the minimum setup value from 120 Hz, F03 (A01), and F15 by 1.2 times. 2- Overspeed error : Displays an error when trains specification of applicable PG is not satisfied.
PG	ON	PG disconnection error : Judges feedback disconnection and displays an error.

4.2 I/O Check

The digital status of the PG option card can be checked on the drive keypad panel. Switch from the run mode screen to the menu screen, then select (4. I/O check). The I/O check monitor has seven screens. Using the up and down keys, scroll through the screens to check the digital input status of the PG option. See the explanation of how to operate the keypad panel in the **VG10** instruction manual.

60	PG/SY option input status
P2= xxxx0p/s	Slave phase –A / phase-B frequency
Z2= xxxp/s	Slave phase – Z frequency

WARNING!

Saftronics manufactures component parts that can be used in a wide variety of industrial applications. The selection and application of *Saftronics* products remains the responsibility of the equipment designer or end user. *Saftronics* accepts no responsibility for how its products may be incorporated into the final design.

Under no circumstances should any *Saftronics* product be incorporated into any product or design as the exclusive or sole safety control. Without exception, all controls should be designed to dynamically fault detect and fail safe under all circumstances. All products designed to incorporate a component part manufactured by *Saftronics*, must be supplied to the end user with appropriate warnings and instructions as to the safe use and operation. Any warnings provided by *Saftronics* must be passed through to the end user.

Saftronics offers an express warranty only as to the quality of its products to conform to the catalog specifications. NO OTHER WARRANTY, EXPRESS OR IMPLIED, IS OFFERED. *Saftronics* assumes no liability for any personal injury, property damage, losses or claims, arising out of the mis-application of its products.