



www.saftronics.com

AIO Analog Input/Output Option Card for the GP10 and VG10

Option Card Part Number
SOPCG11SAIO

Saftronics, Inc.

5580 Enterprise Pkwy., Ft. Myers, FL 33905

Telephone: (239) 693-7200

Fax: (239) 693-2431

www.saftronics.com

Document Part Number 027-2135

Preface



These instructions do not purport to cover all details or variations in equipment, nor to provide every possible contingency to be met during installations, operation, and maintenance. If a further information is desired or if particular problems arise that is not covered sufficiently for the purchaser's purpose, the matter should be referred to Safronics.

Safety Instructions

Read this manual carefully before installing, connecting, operating, servicing, or inspecting the drive.

Familiarize yourself with all safety features before using the drive.

In this manual, safety messages are classified as follows:

 WARNING	Improper operation may result in serious personal injury or death.
 CAUTION	Improper operation may result in slight to medium personal injury or property damage.

Situations more serious than those covered by CAUTION will depend on prevailing circumstances.

Always follow instructions

Instruction on installation and wiring

WARNING

- Wait a minimum of five minutes (30HP or less) or ten minutes (40HP or more) after power has been turned off (open) before starting inspection.
(Also confirm that the charge lamp is off and that DC voltage between terminals P(+) and N(-) does not exceed 25V)
Electrical shock may result.
- A licensed specialist must perform the wiring works, **as electric shock may result.**

CAUTION

- Do not install or operate a damaged option or one that is lacking parts, **as injury may occur.**
- No foreign matter such as screws, metal patches, lint, chips, and dust in the drive option.
There is a risk of fire or accident.
- Do not damage or stress the wiring, **as accident or electric shock may occur.**
- Ensure that the noise generated by the drive, motor, or wiring does not adversely affect peripheral sensors and equipment, **as accident may result.**

Instruction on operation

WARNING

- Be sure to install the surface cover before turning on the power (closed). Do not remove the cover while power to the drive is turned on. **Electrical shock may occur.**
- Check and adjust parameters before operation. Improper parameters may cause an unexpected action for some machines. **There is a risk of accident.**

Maintenance and Inspection, and Parts Replacement

WARNING

- Wait a minimum of five minutes (30HP or less) or ten minutes (40HP or more) after power has been turned off (open) before starting inspection.
(Also confirm that the charge lamp is off and that DC voltage between terminals P(+) and N(-) do not exceed 25V)
Electrical shock may result.
- Only authorized personnel should perform maintenance, inspection, and replacement operations. (Take off metal jewelry such as watches and rings. Use insulated tools.) **Electric shock or injury may result.**

Instructions on disposal

CAUTION

- Treat as industrial waste when disposing it. **Injury may result.**

Other instructions

WARNING

- Never modify the drive option. **Electric shock or injury may result.**

Table of Contents

1 Before Using This Product.....	4
1-1 Outline of product.....	4
1-2 Introduction procedure.....	4
1-3 Receiving inspection.....	5
1-4 Product Appearance.....	5
1-5 Product warranty.....	5
1-6 Storage.....	6
1-6-1 Temporary storage.....	6
1-6-2 Long-term storage.....	6
2 Installation and Connecting.....	6
2-1 Installation method.....	6
2-2 Wiring.....	9
2-2-1 Basic Connection.....	9
2-2-2 Terminal Arrangement.....	10
2-2-3 Terminal Description.....	10
3 Checks Prior to Running.....	10
4 Function Selection.....	11
4-1 Basic block diagram.....	11
4-2 Function Table.....	11
4-3 Detailed explanation for function selection (function code for option).....	12
4-3-1 Selection of analog input function (o22).....	12
4-3-2 Selection of analog output function (o23).....	13
4-3-3 Analog output gain (o24, o25).....	14
5 Operation Procedure.....	15
5-1 Example of independent setting for torque limit value.....	15
5-2 Example of identical setting for torque limit value.....	16
5-3 Example of frequency auxiliary input (V1).....	16
5-4 Example of ratio input.....	17
6 Troubleshooting.....	18
7 Standard Specification.....	19

1 Before Using This Product

1-1 Outline of product

This product is a printed circuit option card to be integrated in the GP10/VG10 drive. It enables analog inputs of torque limit value, frequency auxiliary setting and ratio setting. In addition, the analog output can be mapped to eleven (11) data points in the drive, such as output frequency, current, torque, etc to monitor.

1-2 Introduction Procedure

The procedure from receipt of the product to operation of the drive is described below. As for detailed content of each item, refer to the description mentioned later.

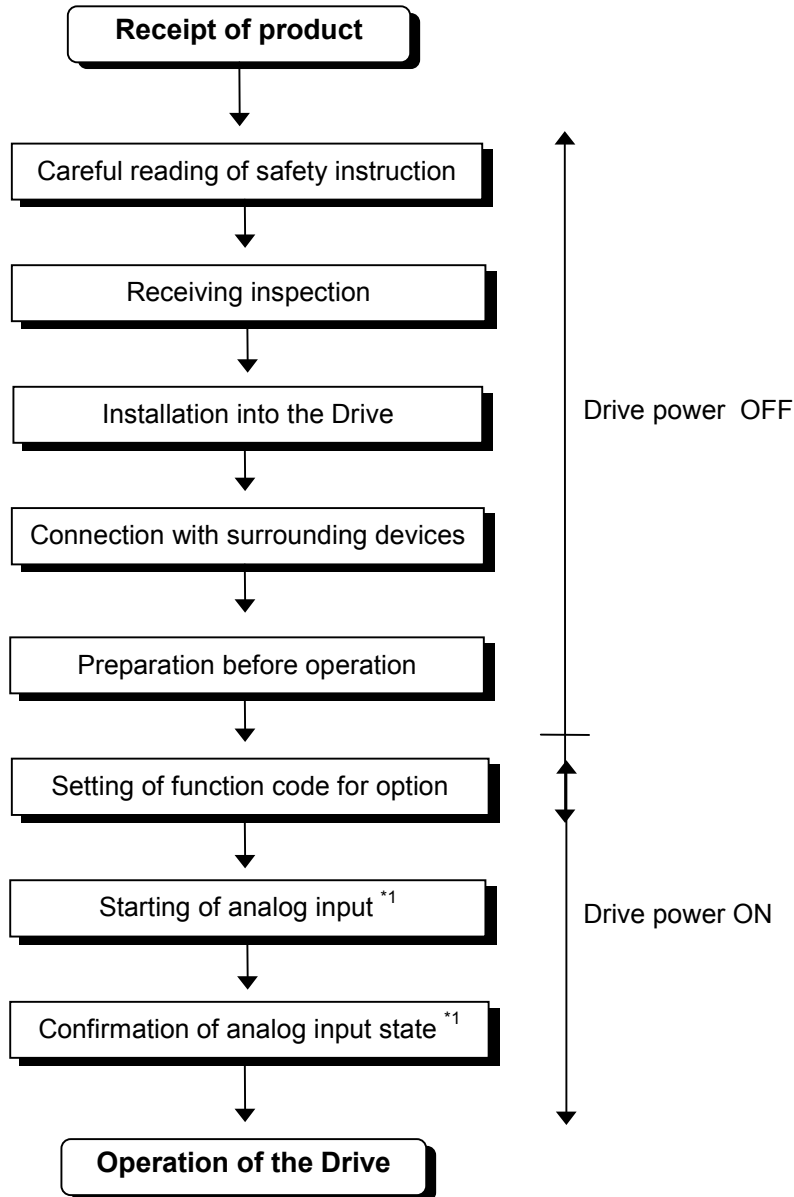

*1) Only when analog input function is used

1-3 Receiving inspection

 CAUTION	<ul style="list-style-type: none"> Do not install or operate a damaged option or one that is lacking parts, as injury may occur.
--	--

Check the items described below when you receive this product. Also check whether this product has been damaged during transport. If anything is amiss, contact your distributor or our nearest branch office.

- 1) Check that the product matches to your purchasing order.
Check that the type printed on the option card is SOPCG11SAIO (refer to "1-4 Product Appearance").

Product type : **SOPCG11S AIO**



- 2) Check that there is no damage during transportation such as broken or falling-off of parts.
- 3) Check that all accessories being complete.

Accessories: Support ----- 3 pieces
 Screw (M3×6) ----- 1 piece

* 30HP or less	: 3 support pieces, 1 screw
* 40HP or more	: 2 support pieces, 1 screw

1-4 Product Appearance

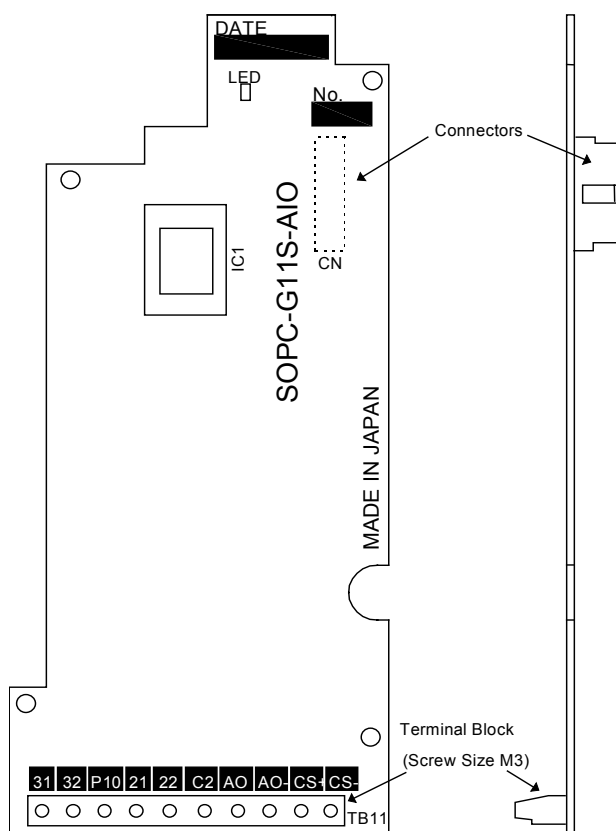

1-5 Product warranty

This product is warranted against defects in workmanship for 12 months after installation or 18 months after shipment from the Company, whichever occurs first. However, the troubles caused by the following reasons are not covered by this warranty even in warranty period.

- Problems caused by incorrect operation or by unauthorized repairs or modifications.
- Problems resulting from using the drive in the range outside the standard specification.
- Damage to the drive after purchase or during delivery.
- Damage caused by earthquakes, fire, floods, lightning, abnormal voltage fluctuations or other natural disasters and secondary disasters.

1-6 Storage

1-6-1 Temporary storage

- 1) Store the option in an indoor area where the same environment conditions as the place to be used.
- 2) Do not place the option directly on a floor. Place it on a stand or shelf.
- 3) When storing the option in an unsuitable atmosphere, pack it in a plastic bag.
- 4) In area of high humidity, pack the option as 3) above after inserting a desiccant (silica-gel etc.).

Item	Specification	
Ambient temperature	-10 to +50°C [+14 to +122°F]	Condensation or freezing must not occur as a result of sudden temperature changes.
Storage temperature	-25 to +65°C [-13 to +149°F]	
Relative humidity	5 to 95%	
Atmosphere	The product must not be exposed to dust, direct sunlight, corrosive gas, flammable gas, oil mist, vapor, water drops, or vibration. There must be a minimum salt content in the atmosphere.	

Note

Specified storage temperature is shown for short term to the extent of transportation. Even if humidity satisfies the specified range, large temperature change may result in dew condensation or freezing. Avoid placing the option in such an area.

1-6-2 Long-term storage

If you do not intend to use the option for a long period of time after purchasing it, the storage method may change according to the environment in the storage location. When severe storage is necessary, refer to the distributor where the option was purchased or Company's sales office.

In general, the following guidelines should be followed:

- 1) Satisfy the requirement for temporarily storage.
- 2) Pack firmly to prevent entrance of humidity etc.. Insert a desiccant (silica-gel etc.). into the packing. The relative humidity in the packing should be kept to 70% or less.
- 3) When this option is installed inside a drive, the drive may be exposed to humidity or dust in many cases, in particular at a location under construction. In such cases, remove the drive, together with the mounted option, and move it to a place with suitable environment, and store in accordance with the Drive User's Guide.

2 Installation and Connecting

2-1 Installation method

 WARNING	<ul style="list-style-type: none"> ● Wait a minimum of five minutes (30HP or less) or ten minutes (40HP or more) after power has been turned off (open) before starting inspection. (Also confirm that the charge lamp is off and that DC voltage between terminals P(+) and N(-) do not exceed 25V) Electrical shock may result.
---	--

 CAUTION	<ul style="list-style-type: none"> ● Do not install or operate a damaged option or one that is lacking parts, as injury may occur. ● No foreign matter such as screws, metal patches, lint, chips, and dust in the drive option. There is a risk of fire or accident. ● Do not damage or stress the wiring, as accident or electric shock may occur.
---	---

**Applicable Drive
GP10(VT)/ VG10 30HP or less
and GP(CT) 25Hp or less**

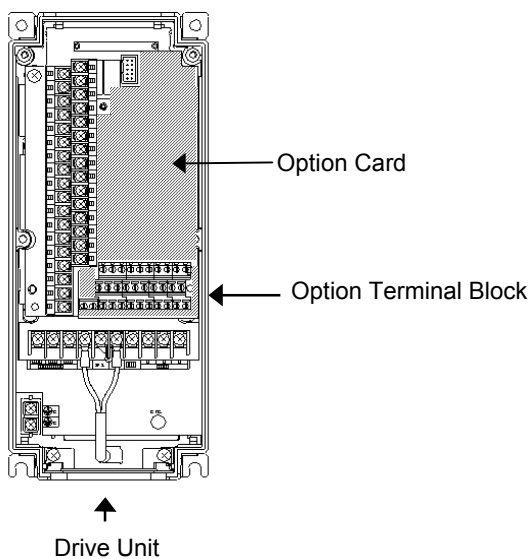
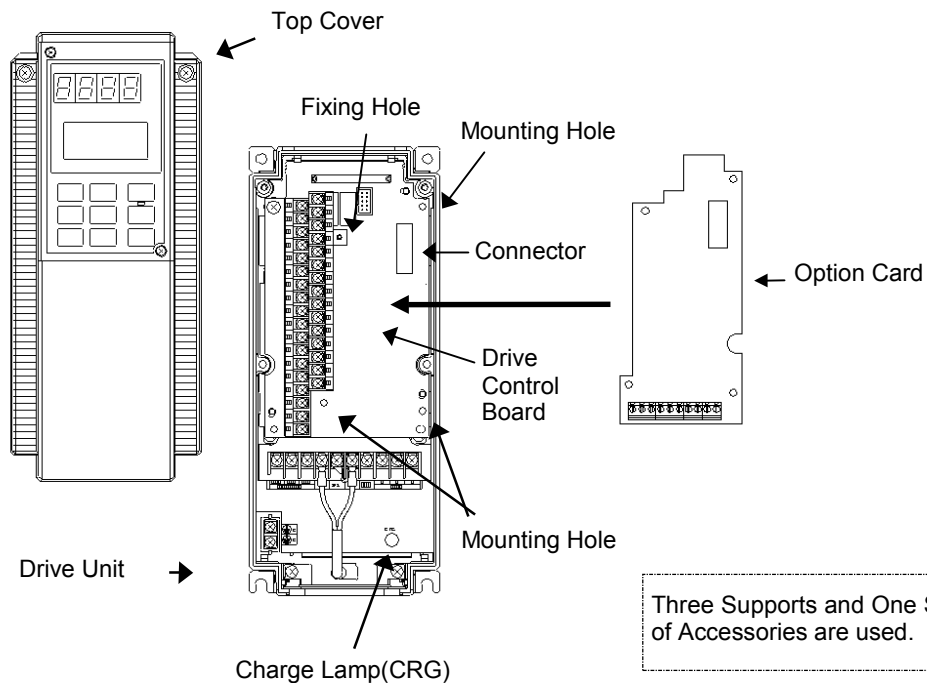

Step 1

Remove the top cover, and insert the accessory supports into the three mounting holes on the Drive control Board.

Step 2

Set the supports inserted in step 1 on the option card, and insert the Drive control board connector to the option card connector. After that, check that you can see the pins of the supports on the option card.

Step 3

Insert and tighten the screws (M3 x 6) in the fixing holes to secure the option card.

Step 4

Wire the option according to the basic connection diagram.

Step 5

Confirm that the option card and all wires are installed correctly, then replace the top cover of the drive.

**Applicable Drive
GP10(VT)/ VG10 40HP or more
and GP(CT) 30Hp or more**

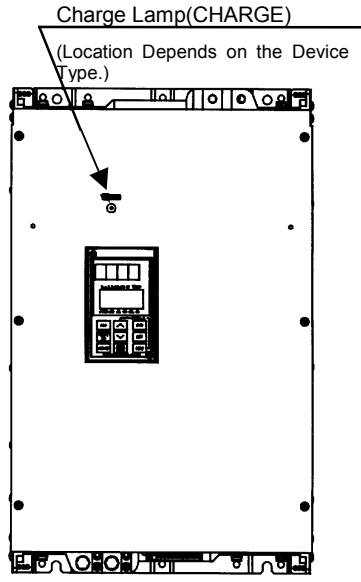
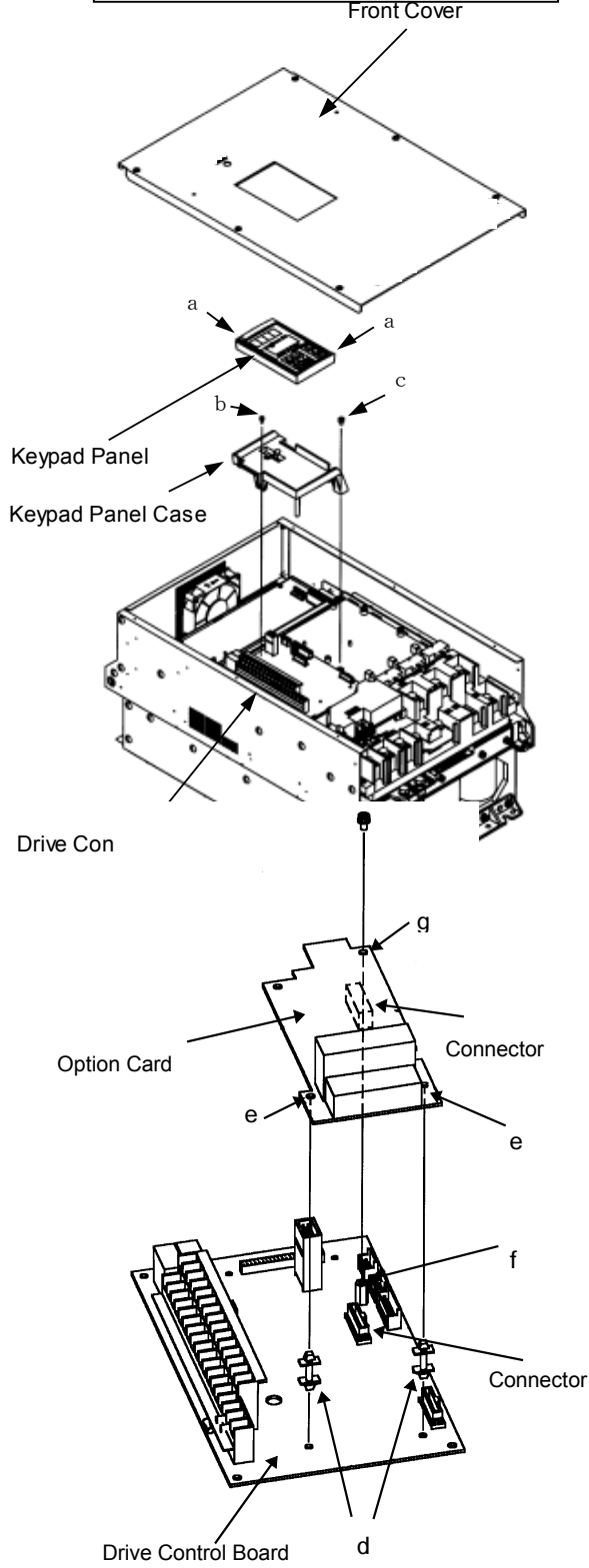

Two Supports and One Screw of Accessories are used.

Step1

Remove the front cover and loosen the two M3 screws (a) to remove the keypad panel.

Step2

Remove one M3 screw (b) and one M4 screw (c) to remove the keypad panel case.

Step3

Insert the two accessory supports (d) into the drive control board.

Step4

Insert the two supports (d) into the holes (e) on the option card. Align the support (f) with the hole (g) on the option card, then insert one connector.

Step5

Insert and tighten the accessory screws (M3 x 6) at (f) and (g) to secure the option card.

Step6

Remount the keypad panel, case, keypad, and the front cover, reassembling the drive.

2-2 Wiring

 WARNING	<ul style="list-style-type: none"> Wait a minimum of five minutes (30HP or less) or ten minutes (40HP or more) after power has been turned off (open) before starting inspection. (Also confirm that the charge lamp is off and that DC voltage between terminals P(+) and N(-) do not exceed 25V) Electrical shock may result. A licensed specialist must perform the wiring works, as electric shock may result.
---	---

 CAUTION	<ul style="list-style-type: none"> Ensure that the noise generated by the drive, motor, or wiring does not adversely affect peripheral sensors and equipment, as accidents may result.
---	--

2-2-1 Basic Connection

Refer to the following notes when connecting.

Attention during connection:

Keep the option card wiring away from the main power circuit wiring of the drive and other power wires to prevent malfunction due to noise coupling.

Never RUN control wires in the same conduit or wire tray as the power wires.

(A minimum separation of 1 foot (30cm) is recommended.)

Basic Connection Diagram

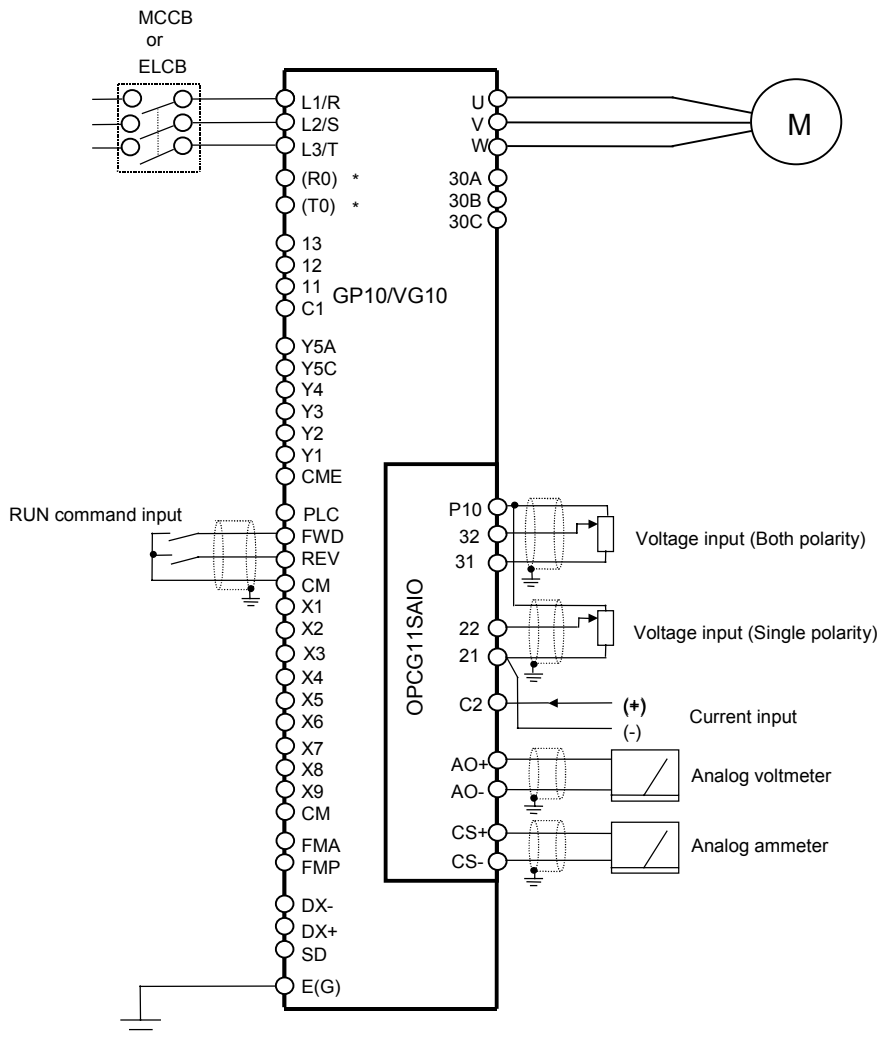

* Terminals [R0] and [T0] are not provided for 1.0HP or smaller.

2-2-2 Terminal Arrangement

31	32	P10	21	22	C2	AO+	AO-	CS+	CS-
----	----	-----	----	----	----	-----	-----	-----	-----

2-2-3 Terminal Description

Division	Terminal Symbol	Terminal Name	Function Explanation
Analog input	P10	Potentiometer Power supply	Power supply for potentiometer (1 to 5 k Ω) · DC +10V 10mA
	22	Voltage input (Positive polarity)	· DC 0 to +10V / 0 to 100% (Input impedance 22 k Ω)
	32	Voltage input (Both polarities)	· DC 0 to \pm 10V / 0 to \pm 100% (Input impedance 22 k Ω)
	C2	Current input	· DC 4 to 20mA / 0 to 100% (Input impedance 250 Ω)
	21, 31	Common terminal	Common terminals for 22, 32 and C2 terminals.
Analog output	AO+	Analog monitor (Voltage)	For analog voltmeter · DC 0 to \pm 10V Up to two analog voltmeters can be connected. (Input impedance 10 k Ω)
	AO-	Analog monitor Common terminal	Common terminal for AO+
	CS+	Analog monitor (Current)	For analog ammeter · DC 4 to 20mA Max. connectable impedance 500 Ω
	CS-	Analog monitor Common terminal (Isolated)	Exclusive use common terminal for CS+ (Isolated from 21, 31 and AO- terminal)

3 Checks Prior to Running

After installation and wiring, check the following items before applying the input power to the drive.

- 1) The wiring is correct.
- 2) Insure no loose wires or screws remain inside the drive.
- 3) The screws and terminals are all tight.
- 4) There are no loose threads of wires at terminals that may contact other terminals.

In addition, check the following items, after turning on the drive power and before starting the operation.

 WARNING	<ul style="list-style-type: none"> ● Be sure to install the surface cover before turning on the power (closed). Do not remove the cover while power to the drive is turned on. Electrical shock may occur. ● Check and adjust parameters before operation. Improper parameters may cause an unexpected action for some machines. There is a risk of an accident.
---	--

- 1) Check that the function code for the AIO option (o22 to o25) is set correctly.
(Refer to "4-3. Detailed explanation for function selection (function code for option)" as to function code for option.)
- 2) Check that the correct current and voltage is connected through the analog input terminal.

4 Function Selection

4-1 Basic block diagram

The block diagram of AIO option is shown below.

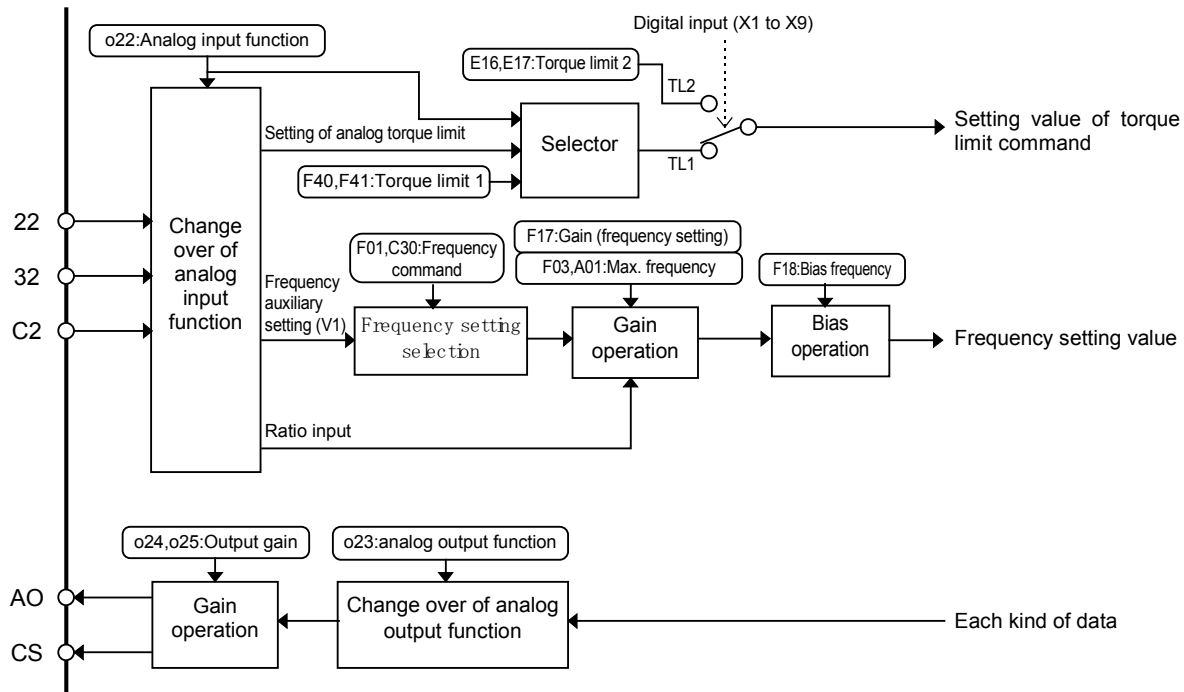

4-2 Function Table

The function code which relates to the AIO option function is shown below.

(Function code o22 to o25 for the option can be set from the keypad panel by connecting the AIO option.)

Func No.	Name	Setting Range	Unit	Min. Unit	Factory Setting	Change during operation	User Set value
F01	Frequency command 1	0 to 11	-	-	0	N	
F03	Maximum frequency 1	VG10: 50 to 400Hz GP10: 50 to 120Hz	Hz	1	60	N	
F17	Gain (for frequency setting signal)	0.0 to 200.0%	%	0.1	100.0	Y	
F18	Bias frequency	VG10: -400.0 to 400.0Hz GP10: -120.0 to 120.0Hz	Hz	0.1	0.0	Y	
F40	Torque limiter 1 (Driving) (Breaking)	VG10: 20 to 200%, 999 GP10: 20 to 150%, 999	%	1	999	Y	
F41		VG10: 0%, 20 to 200%, 999 GP10: 0%, 20 to 150%, 999					
E16	Torque limiter 2 (Driving) (Breaking)	VG10: 20 to 200%, 999 GP10: 20 to 150%, 999	%	1	999	Y	
E17		VG10: 0%, 20 to 200%, 999 GP10: 0%, 20 to 150%, 999					
C30	Frequency command 2	0 to 11	-	-	2	N	
C33	Analog setting signal filter	0.00 to 5.00s	s	0.01	0.05	Y	
A01	Maximum frequency 2	VG10: 50 to 400Hz GP10: 50 to 120Hz	Hz	1	60	N	
o22	Analog input function	000 to 555	-	-	000	N	
o23	Analog output function	00 _H to AA _H	-	-	00 _H	Y	
o24	Voltage output gain	0.0 to 200.0%	%	0.1	100.0	Y	
o25	Current output gain	0.0 to 200.0%	%	0.1	100.0	Y	

4-3 Detailed explanation for function selection (function code for option)

4-3-1 Selection of analog input function (o22)

The selection of function to be set is possible through analog input terminal (22, 32, C2).

o22 Analog input function

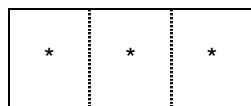

Selection of current input (C2) function 0 to 5 (Factory setting is 0)
 Selection of voltage input (32) function 0 to 5 (Factory setting is 0)
 Selection of voltage input (22) function 0 to 5 (Factory setting is 0)

Setting Value	Function Name	Function	Description	Operation Procedure
0	AI inactive	Analog input is inactive.	Set this value by not using analog input terminals.	-
1	Driving torque limit value	For independent torque limit setting	22, 32 terminal : 0 to +10V / 0 to 200% (Fixed to 20%, if it is less than 1V) C2 terminal : 4 to 20mA / 0 to 200% (Fixed to 20%, if it is less than 5.6mA) * In the case of GP10, it is limited at 150%	Refer to 5-1
2	Braking torque limit value			
3	Driving and braking torque limit value	For identical torque limits setting (driving and braking)	Torque limit value, which is not selected Ai torque limit function, is set by function code F40, F41.	Refer to 5-2
4	Frequency auxiliary setting (V1)	This function is active by setting function code F01 or C30 (terminal V1)	22 terminal : 0 to +10V / 0 to +100% (100% is Max. frequency) 32 terminal : 0 to ±10V / 0 to ±100% (100% is Max. frequency) C2 terminal : 4 to 20mA / 0 to 100% (100% is Max. frequency)	Refer to 5-3
5	Ratio setting	For ratio setting	22, 32 terminal : 0 to +10V / 0 to 100% (Fixed to 0%, if it is negative input) C2 terminal : 4 to 20mA / 0 to 100%	Refer to 5-4

$$\text{Frequency Setting (Output Freq.)} = \frac{\text{Analog Frequency Reference}}{\text{Reference}} \times \frac{\text{Ratio Setting (O22)}}{100\%} \times \frac{\text{Frequency Gain (F17 Gain)}}{100\%}$$

Note

- 1) When the same function is set from multiple sources at "o22 : Analog input function", the priority is voltage input (22), voltage input (32) and then current input (C2).

Example : When 111 is set at o22, setting of the driving torque limit value is possible by voltage input (22).

- 2) Even when the setting of torque limit being selected (o22=1 to 3), if the digital input terminal (X1 to X9) is changed over to torque limit 2 (TL2), the setting at 22· 32· C2 terminals is neglected and setting of limit value at function code E16, E17 is used.

4-3-2 Selection of analog output function (o23)

Selection of the function output from the analog output terminal (AO,CS) is possible.

o23 Analog output function

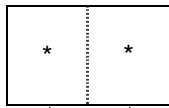

Selection of current output (CS) function 0_H to A_H (Factory setting is 0_H)
 Selection of voltage output (AO) function 0_H to A_H (Factory setting is 0_H)

Setting Value	Function	Definition of monitor amount 100%	Notes
0_H	Output frequency 1 (Before slip compensation)	Maximum frequency	Positive out: FWD operation Negative output: REV operation (In the case of current output, data with both polarities is output in an absolute value.)
1_H	Output frequency 2 (After slip compensation)	Maximum frequency	
2_H	Output current	Drive rated current $\times 2$	
3_H	Output voltage	200V type : 250V 400V type : 500V	
4_H	Output torque	Motor rated torque $\times 2$	Positive out: In Driving Negative output: In Braking (In the case of current output, data with both polarities is output in an absolute value.)
5_H	Load factor	Motor rated load factor $\times 2$	
6_H	Input power	Drive rated output $\times 2$	Positive out: In Driving Zero output: In Braking
7_H	PID feedback value	Maximum feedback value	Positive output only
8_H	PG feedback value (Only when option is installed)	Maximum speed	Positive out: FWD operation Negative output: REV operation (In the case of current output, data with both polarities is output in an absolute value.)
9_H	DC link circuit voltage	200V type : 500V 400V type : 1000V	
A_H	Universal AO	$\pm 20000d$	(In the case of current output, data with both polarities is output in an absolute value.)

Note

- 1) Output frequency 1, output frequency 2, output torque, load factor and universal AO is an output of both positive and negative polarity at the output. When a single amplitude meter is used, utilize FMA terminal of the drive.
- 2) When the AIO option card is used, the PG feedback signal cannot be used. Therefore, the PG feedback value, if selected, will be zero.
- 3) The universal AO is a function to utilize analog output (AO, CS) via communication network.
(Refer to the instruction manual of RS485 as to the utilizing method).

4-3-3 Analog output gain (o24, o25)

The gain at analog output can be set.

Function code	Description	Setting range
o24	Setting of voltage output gain	0.0 to 200.0%
o25	Setting of current output gain	0.0 to 200.0%

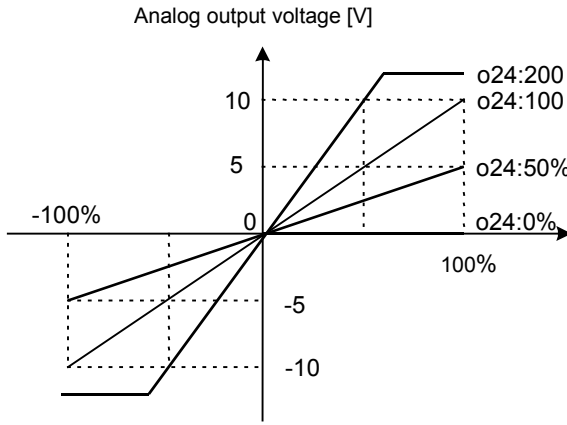

Gain adjustment of analog voltage output

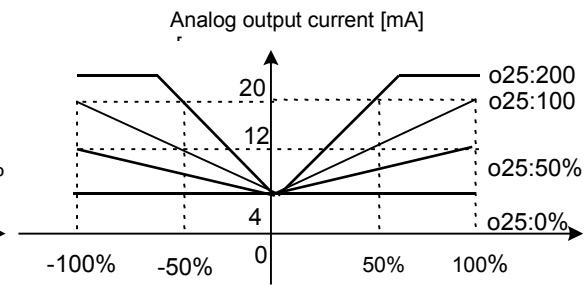

Gain adjustment of analog current output

5 Operation Procedure

5-1 Example of independent setting for torque limit value

An example of the operation procedure when the analog input terminal (22) is used for the setting of driving torque limit value, and the analog input terminal (32) is used for the setting of braking torque limit value is shown below.

- 1) After installation and connection of this option (SOPCG11SAIO) in the drive, turn on the power.
- 2) Set "o22: Analog input function" to 120 using the keypad panel.

o22 Analog input function

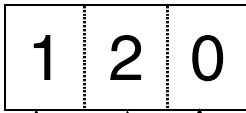

- Selection of current input (C2) function (0:Ai inactive)
- Selection of voltage input (32) function (2:Braking torque limit value)
- Selection of voltage input (22) function (1:Driving torque limit value)

- 3) Set the driving torque limit value using the analog input terminal (22).
The setting value can be checked by the operation state monitor (TLD) on the keypad panel.

Driving torque limit value (TLD) [%]

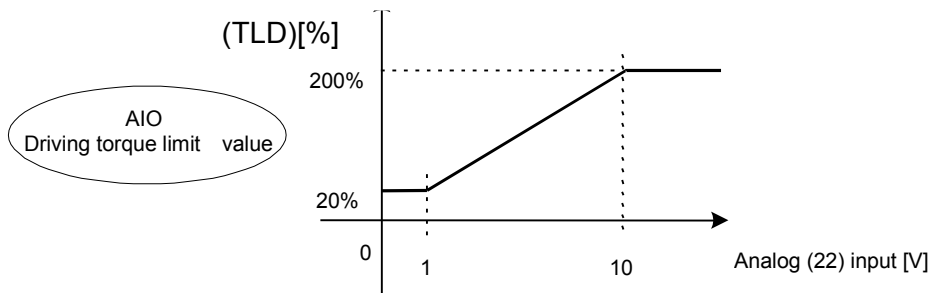

- 4) Set the braking torque limit value using the analog input terminal (32).
The setting value can be checked by the operation state monitor (TLB) on the keypad panel.

Braking torque limit value (TLB) [%]

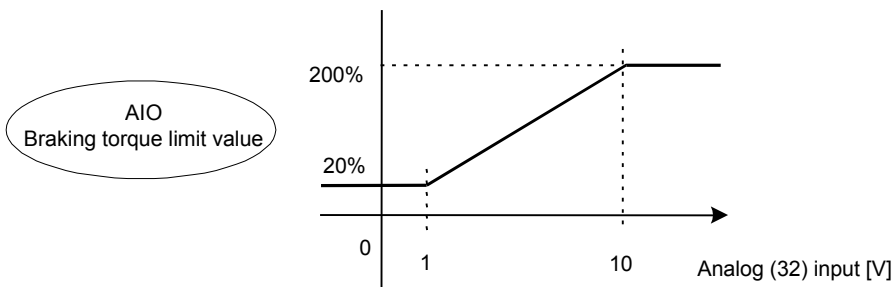

- 5) Confirm the function code setting.
Set the function code suited to your system requirements.
(Refer to the Drive User's Guide and this manual for further explanations of the function codes).

5-2 Example of identical setting for torque limit value

An example of the operation procedure when the analog input terminal (22) is used for the setting of driving and braking torque limit value is shown below.

- 1) After installation and connection of this option (SOPCG11SAIO) in the drive, turn on the power.
- 2) Set "o22: Analog input function" to 300 using the keypad panel.

o22 Analog input function

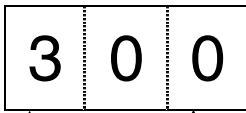

- Selection of current input (C2) function (0:AI inactive)
- Selection of voltage input (32) function (0:AI inactive)
- Selection of voltage input (22) function (3:Driving and braking torque limit value)

- 3) Set the driving and braking torque limit value using the analog input terminal (22).
The setting value can be checked by the operation state monitor (TLD, TLB) on the keypad panel.

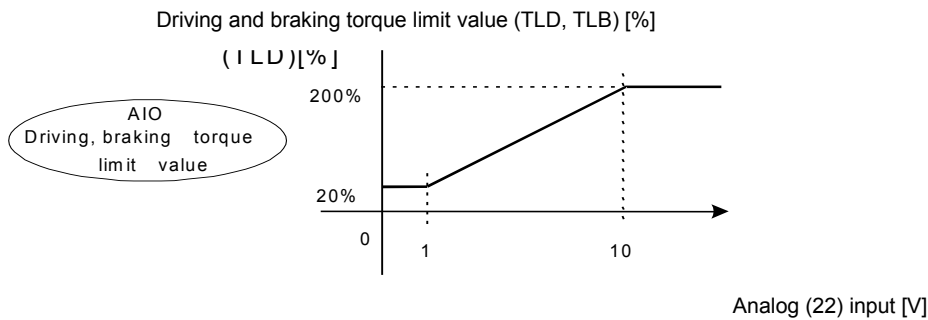

- 4) Confirm the function code setting.
Set to the function code suited to your system requirements.
(Refer to the Drive User's Guide and this manual for further explanation of the function codes.)

5-3 Example of frequency auxiliary input (V1)

An example of operation procedure when the analog input terminal (22) is used for the setting of frequency auxiliary input (V1) is shown below.

- 1) After installation and connection of this option (SOPCG11SAIO) in the drive, turn on the power.
- 2) Set "o22: Analog input function" to 400 using the keypad panel.

o22 Analog input function

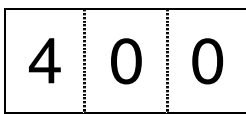

- Selection of current input (C2) function (0:AI inactive)
- Selection of voltage input (32) function (0:AI inactive)
- Selection of voltage input (22) function (4:Frequency auxiliary setting)

- 3) Input the auxiliary frequency using analog input terminal (22).
The input voltage can be checked by the I/O check (22) on the keypad panel.

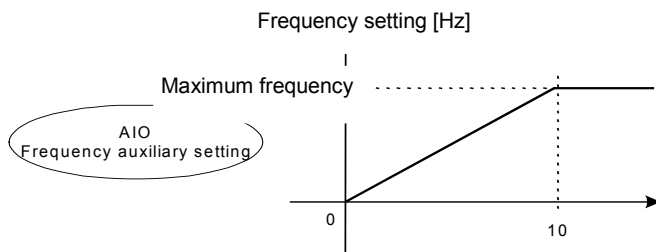

- 4) Setting of the frequency command, function code F01, C30.
- 5) Select the setting method of frequency. Since it is the auxiliary frequency input from the option, select data 5 (terminal 12, V2, and C2 input). (Refer to the Drive User's Guide for details).

Function code	Description	Setting range	Setting value
F01, C30	Frequency command 1, 2	0 to 11	5 (12+V2input)

The frequency command is determined by adding inputs on terminal 12, V2 and C2.

In case only the frequency auxiliary input is used, and if the input of 12 terminal is left as open state, the frequency command value may become unstable affected by noise etc.

- 5) Setting of frequency gain, function code F17.
Set the gain of frequency setting value for the analog frequency command (12, C2, V2) by the function code. (Refer to the Drive User's Guide for details).

Function code	Description	Setting range	Setting value
F17	Gain(frequency setting signal)	0.0 to 200.0%	Spontaneous

- 6) Confirmation of the frequency command value set at the present
Confirm the setting frequency (Fref) by the operation state monitor on the keypad panel.
- 7) Confirm the function code settings.
Set to the function code suited to your system requirements.
(Refer to the Drive User's Guide and this manual for further explanation of the function codes).

5-4 Example of ratio input

An example of operation procedure when the analog input terminal (22) is used for the setting of the ratio input is shown below.

- 1) After installation and connection of this option (SOPCG11SAIO) in the drive, turn on the power.
- 2) Set "o22: Analog input function" to 500 using the keypad panel.

o22 Analog input function

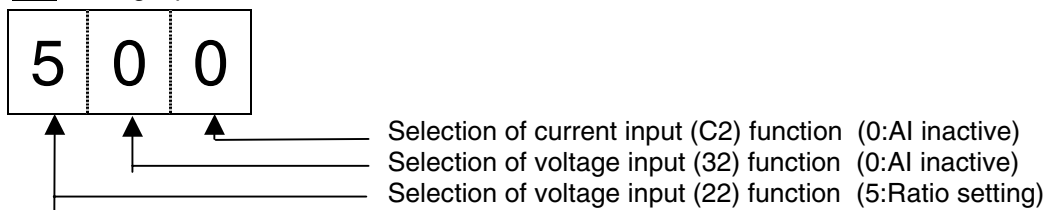

- 3) Set the ratio by analog input terminal (22).
To set the ratio of 80%, input the voltage of 8V.
Input voltage can be checked by the I/O check (22) on the keypad panel.

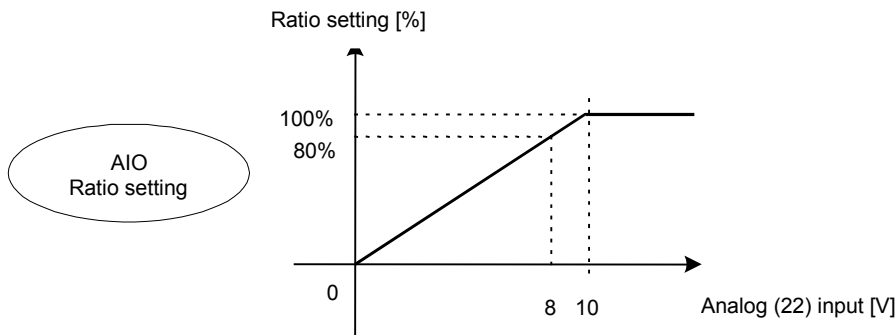

- 4) Setting of the maximum frequency, function code F03, A01
 Set the maximum frequency of the drive output by function code.
 (Refer to the Drive User's Guide for details).

Function code	Description	Setting range
F03, A01	Maximum frequency 1, 2	VG10: 50 to 400Hz GP10: 50 to 120Hz

- 5) Setting of the frequency gain, function code F17
 Set the gain of frequency setting value for the analog frequency command (12, C2, V2) by the function code.
 (Refer to the Drive User's Guide for details).

Function code	Description	Setting range	Setting value
F17	Gain(frequency setting signal)	0.0 to 200.0%	100.0%

- 6) Confirm the frequency command setting (Fref) by using the keypad panel.
- 7) Confirm the function code settings.
 Set to the function code suited to your system requirements.
 (Refer to the Drive User's Guide and this manual for further explanation of the function codes).

6 Troubleshooting

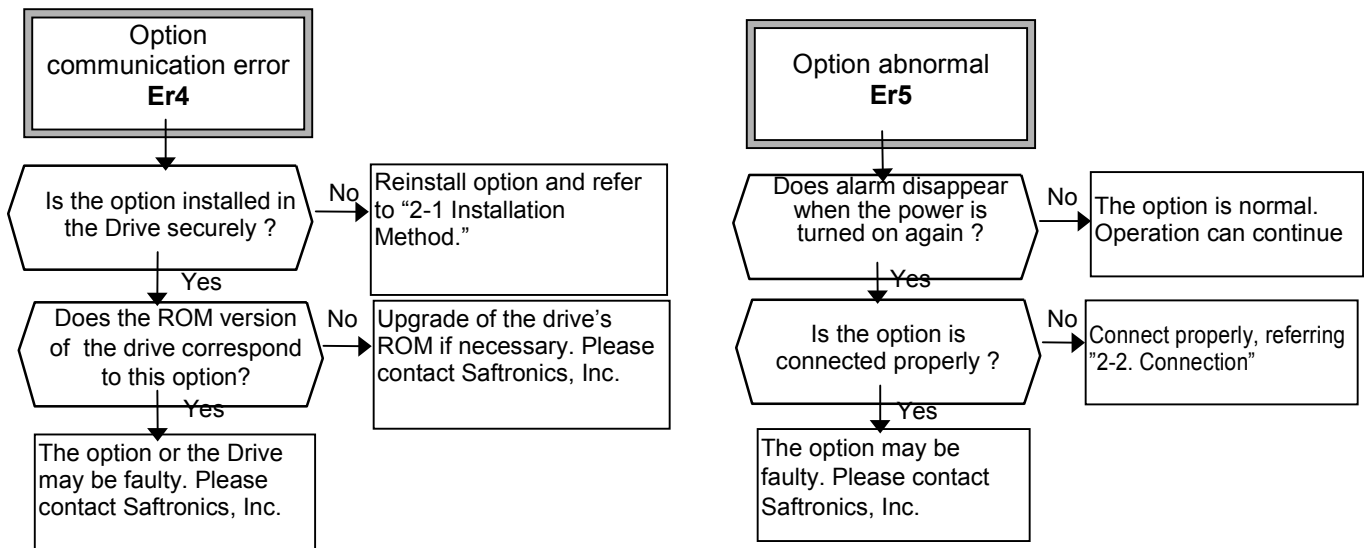

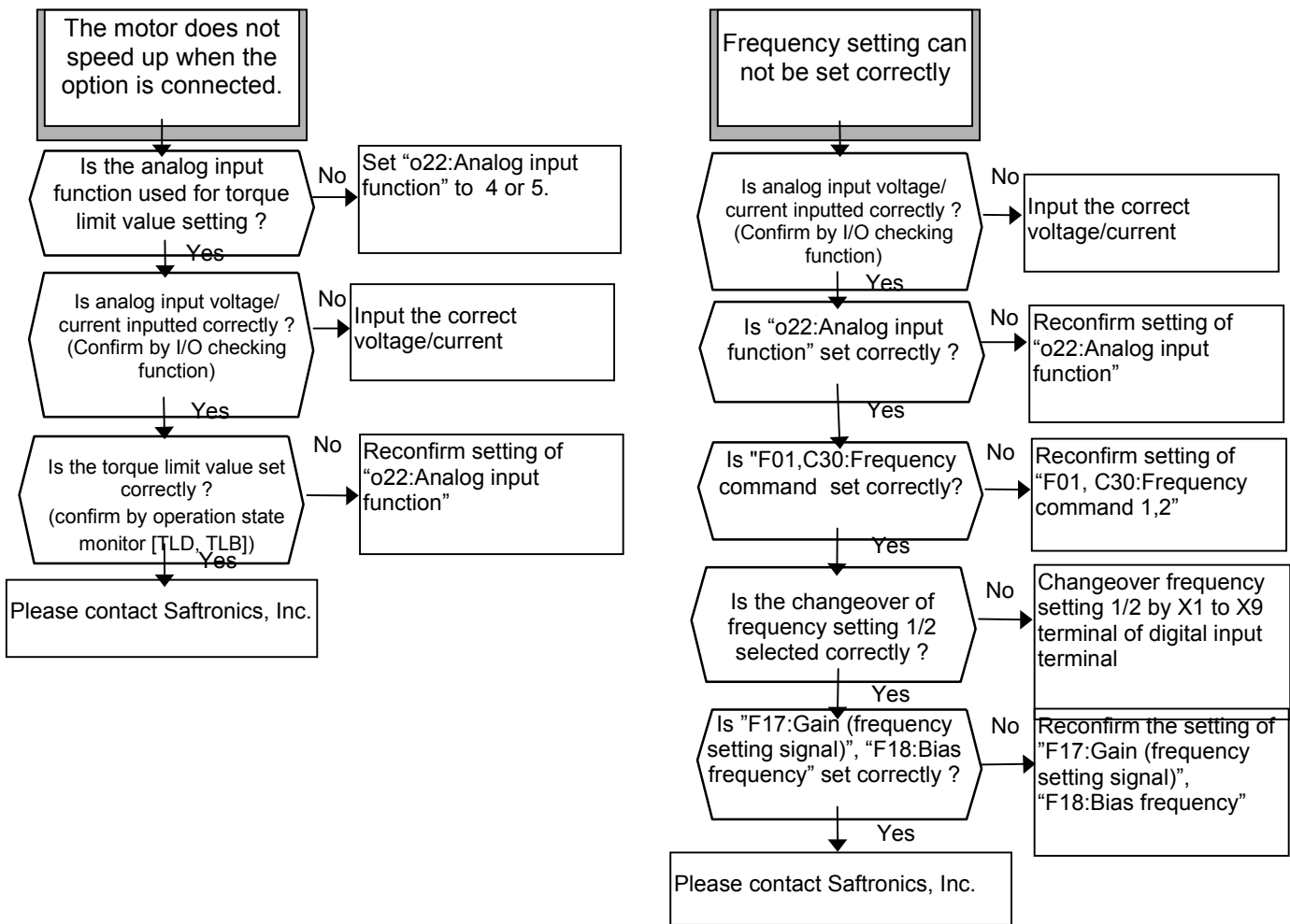

7 Standard Specification

Item		Specification	
Designation		Analog Interface Option	
Model		SOPCG11SAIO	
Protecting function		Er4	Option communication error (communication error between option and drive)
		Er5	Option abnormal (Abnormality of option hardware)
Environment	Location	Indoor (Remove the ventilation cover for drives of 5HP or less).	
	Ambient temperature	-10 to +50C [+14 to 122F]	When ambient temperature exceed +40C [104F], remove the ventilation cover for Drive of 30HP or less.(NEMA1 only) -10 to +40C for NEMA4/12
	Relative humidity	5 to 95%	
	Atmosphere	The product must not be exposed to dust, direct sunlight, corrosive gas, oil mist, vapor, or water drops. There must be a minimum salt content in the atmosphere. Do not store where condensation may occur as a result of sudden changes in temperature.	
	Altitude	1000m[3300feet] or lower	
	Vibration	5.9m/s ² (0.6G) or less	
Storage	Ambient temperature	-25 to +65C[-13 to +149F]	Applicable for short term such as transportation
	Ambient humidity	5 to 95% (There should be no dew condensation)	

Note

- 1) This option is a specific option for general use with the GP10/VG10 series of the Safronics drives. It is impossible to use other products.
- 2) Confirm the ROM version by checking the maintenance information on the keypad panel.
(The ROM version of the option can confirm also by checking the IC1 seal name plate on the option).

INV =Hxxxxx
KEYPAD=Kxxxxx
OPTION=Pxxxxx

Keypad panel screen

←ROM version :Drive 40HP or more: Hxxxxx, 30HP or less: Sxxxxx)

←ROM version :Keypad panel

←ROM version :Option

- 3) Do not perform a megger test at the terminals of the option.
- 4) When actuate protection function of the drive, operation should start again after removal of the cause of alarm, referring troubleshooting in the operation manual of drive.
- 5) The items for maintenance and inspection are the same as the drive. Refer to the Drive User's Guide.
- 6) When the environmental condition cannot be satisfied, it may result in deterioration of performance or usable life as well as failure.