



PG2 Encoder Feedback Option Card for The VG10

Option Card Part Number
SOPCG11SPG2

Saftronics, Inc.

5580 Enterprise Pkwy., Ft. Myers, FL 33905

Telephone: (239) 693-7200

Fax: (239) 693-2431

www.saftronics.com

Document Part Number 027-2137

Preface

These instructions do not purport to cover all details or variations in equipment, nor to provide every possible contingency to be met during installation, operation, and maintenance. If further information is desired or if particular problems arise that is not covered sufficiently for the purchaser's purpose, the matter should be referred to Safronics, Inc., Ft. Myers, and FL.

To Use the Option Safely

Note the following items when using the option. Improper use may result in unexpected failure, electric shock, or possible injury.

(1) Installation and Wiring

WARNING

Wait at least five minutes after turning off the power before installing or wiring the drive option.
Use a multi-meter or similar instrument to check the voltage before performing installation or wiring. (Check whether the charge lamp goes off.), **as electric shock may occur**
Discharge static electricity from your body before handling the drive option. Never touch the drive option with wet hands, **as accident or electric shock may occur**
No foreign matter such as screws, metal patches, lint, chips, and dust in the drive option.
There is risk of fire or accident.
Do not damage or stress the wiring, **as accident or electric shock may occur.**

CAUTION

Do not install or operate a damaged option or one that is lacking parts, **as injury may occur.**
Since noise is generated by the drive, motor, and wiring, carefully monitor surrounding sensors and devices for abnormal operation. **There is a risk of accident.**

(2) Operation

WARNING

Check and adjust parameters before operation. Improper parameters may cause an unexpected action for some machines. **There is a risk of accident.**

CAUTION

High-speed operation can be set easily for the drive. Fully check motor or device performance before changing the setup, **as accident may occur.**

(3) Maintenance and Inspection, and Parts Replacement

WARNING

Wait at least five minutes after turning off the power before inspecting the drive option. (Check whether the charge lamp goes off.) **There is a risk of electric shock.**
Only authorized personnel are allowed to maintain and inspect the drive option and replace parts, **as electric shock or injury may occur.**
Never modify the drive option, **as electric shock or injury may occur.**

CAUTION

Do not execute a megger test (insulation resistance measurement).

(4) Discard

CAUTION

Since the drive option uses soldering lead, treat it as an industrial waste when discarding it.

1 Before Using this Product	
1-1 Applicable CPU Number	3
1-2 Checking Accessories	3
1-3 Product Appearance.....	3
2 Product Inquiries	
2-1 Overview.....	4
2-2 Product Guarantee	4
3 Installation	
3-1 Installation Environment	4
3-2 Installation Procedure.....	5
3-3 Wiring.....	7
3-4 Applicable PG.....	8
4 Option Power Supply Settings	
4-1 Option Power Supply Settings.....	8
4-2 Setting of SW.....	9
5 PG Vector Control	
5-1 Basic Connection Diagram	9
5-2 Terminal Functions	10
5-3 Function Codes.....	12
5-4 PG Polarity.....	13
5-5 Function Code Settings	13
5-6 Notes on Use.....	15
5-7 Control Specifications.....	15
5-8 Function Codes (Specifications when PG Vector Control Used)	15
6 Additional Information	
6-1 Alarm Protection Function	19
6-2 I/O Check.....	19

If anything is unclear about the option or there is something doubtful about its condition, contact your distributor or our nearest branch office.

1 Before Using this Product

Check the items described below when you receive this product. Also check whether this product has been damaged during transport. If anything is amiss, contact your distributor or our nearest branch office.

1-1 Applicable CPU Number

The drive option can be used in a drive with a ROM version number listed in Table 1-1-1. Check the ROM number in the maintenance information on the keypad panel.

Table 1-1-1 Applicable ROM version numbers.

Drive Series	Drive Capacity	Drive ROM Version Number
VG10	30 HP or less	S07000 or later
	40 HP or more	H07000 or later

1-2 Checking Accessories

Confirm that the following accessories are included in the package:

- 1. Instruction Manual..... 1
- 2. Accessories 1) Mounting screw M3 x 6..... 1
- 2) Supports 3

1-3 Checking Accessories

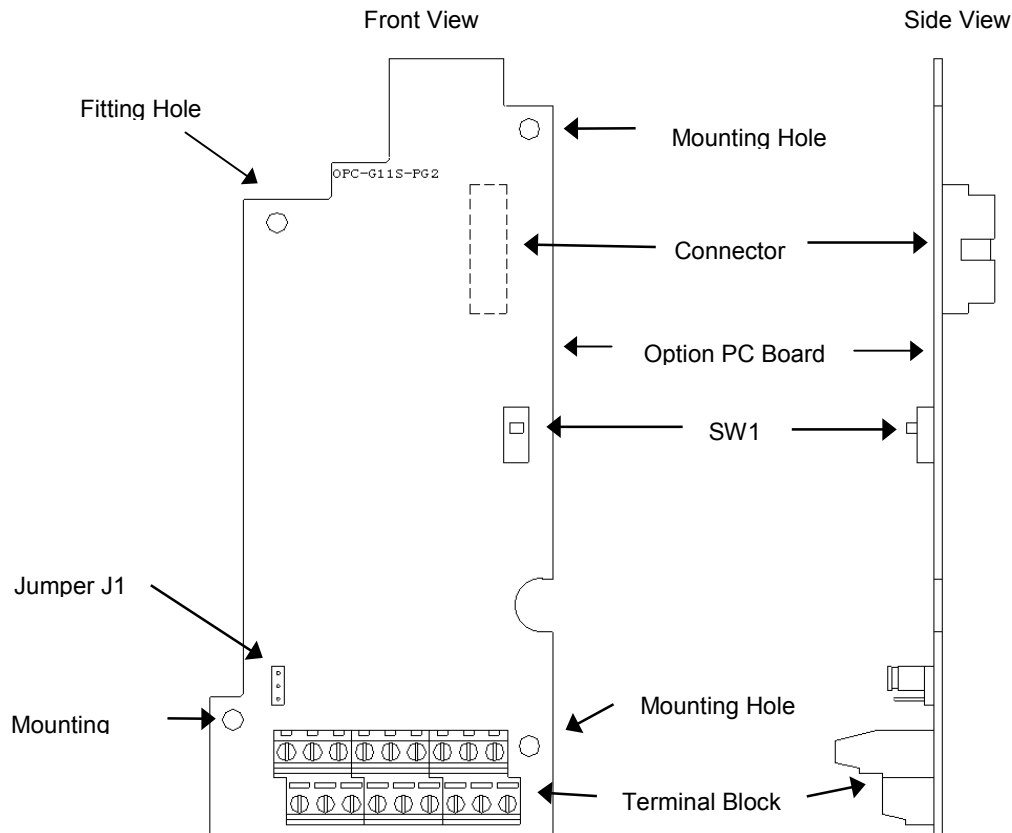

Figure1-3-1 Product Appearance.

2 Product Inquiries

2-1 Overview

This product is an interface card that is installed in the VG10 general-purpose drive. "Vector control" is possible because of the feedback signal by PG (5V Line driver type).

2-2 Product Guarantee

The product guarantee term is twelve (12) months after installation or eighteen (18) months after manufacturing on the nameplate, whichever expires first.

However, the guarantee will not apply in the following cases, even if the guarantee term has not expired:

- (1) Problems caused by incorrect operation or by unauthorized repairs or modifications.
- (2) Problems resulting from using the drive in the range outside the standard specification.
- (3) Damage to the drive after purchase or during delivery.
- (4) Damage caused by earthquakes, fire, floods, lightning, abnormal voltage fluctuations or other natural disasters and secondary disasters.

3 Installation

3-1 Installation Environment

The installation environment for the drive in which this product is being installed is listed Table 3-1-1

Table 3-1-1 Installation Environment.

Item	Specifications	Remarks
Location	Indoors	
Ambient temperature	-10 to 50°C(+14 to +122°F) , -10 to 40°C(+14 to 104°F) for NEMA4/12 (Remove the ventilation cover of the Drive when the temperature exceeds +40°C (30HP or less).)	
Ambient relative humidity	5 to 95%	
Environment	The place should be away from direct sunlight and free from dust, corrosive gases, inflammable gases, oil mists, steam, dripping water or vibration. Salty environments should preferably be avoided. Avoid places where sudden changes in temperature occur which could cause condensation or freezing.	
Altitude	Up to 3300 feet (1000m)	

3-2 Installation Procedure

Before installing or removing the option, be sure to turn off input power to the drive and confirm that the charge lamp (CHARGE or CRG) is off.

**Applicable Drive
VG10 30 HP or less**

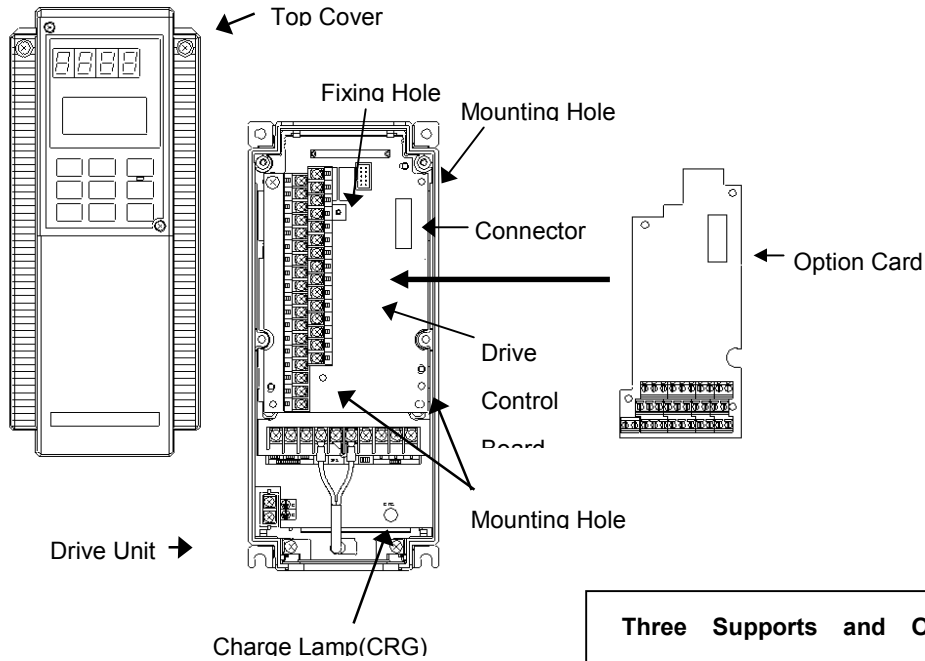

**Three Supports and One
Screw of Accessories are**

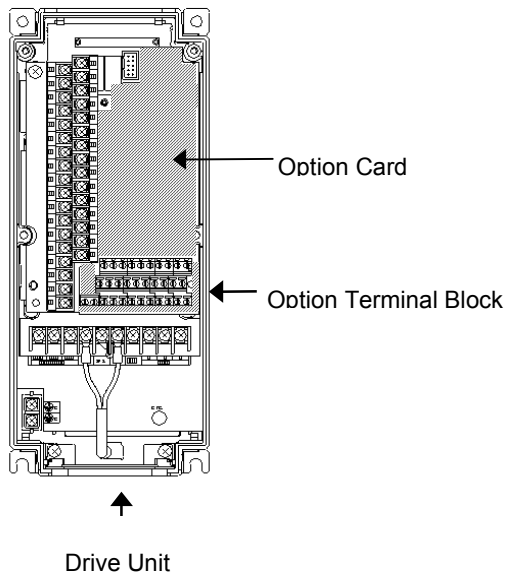

Step1

Remove the top cover, and insert the accessory supports into the three mounting holes on the drive control board

Step2

Set the supports inserted in step 1 on the option card, and insert the drive control board connector to the option card connector. After that, check that you can see the pins of the supports on the option card

Step3

Insert and tighten the screw (M3 x 6) in the fixing holes to secure the option card.

Step4

Wire the option according to the basic connection diagram.

Step5

Confirm that the option card and all wires are installed correctly, then replace the top cover of the drive.

**Applicable Drive
VG10 40 HP and above**

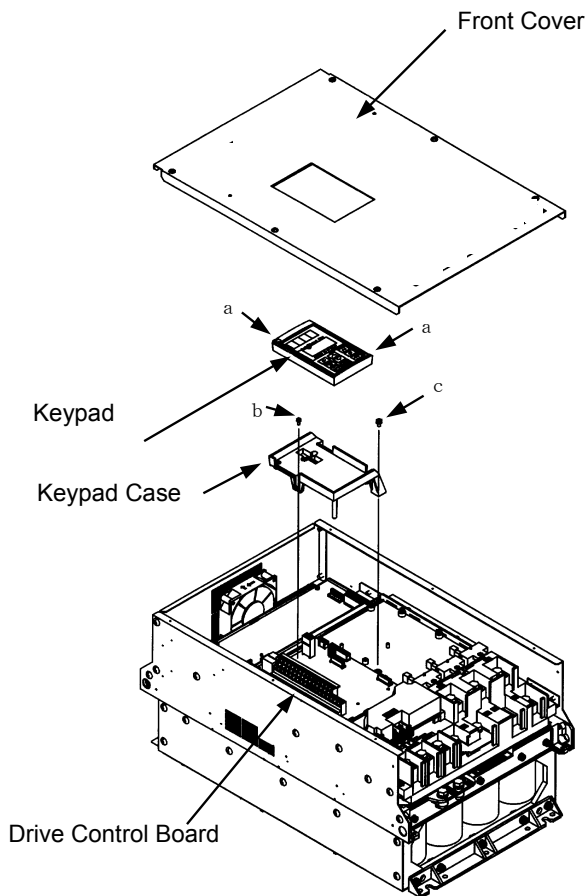

**Two Supports and One Screw of
Accessories are used.**

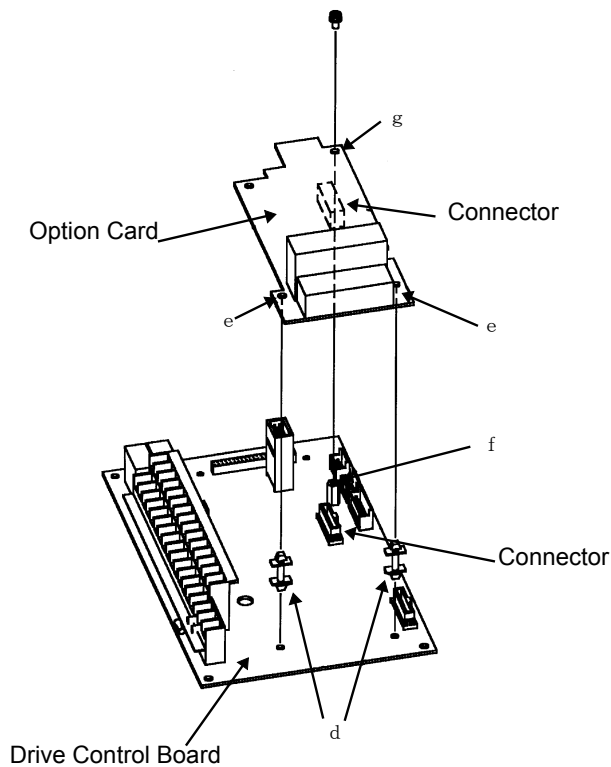
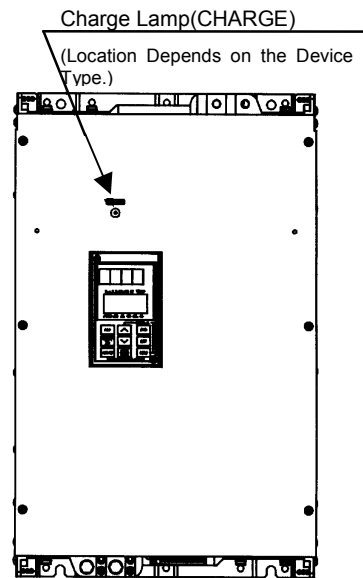

Step 1

Remove the front cover and loosen the two M3 screws (a) to remove the keypad panel.

Step 2

Remove one M3 screw (b) and one M4 screw (c) to remove the keypad panel case.

Step 3

Insert the two accessory supports (d) into the drive control board.

Step 4

Insert the two supports (d) into the holes (e) on the option card. Align the support (f) with the hole (g) on the option card, then and insert one connector.

Step 5

Insert and tighten the accessory screws (M3 x 6) at (f) and (g) to secure the option card.

Step 6

Replace the keypad panel, case, keypad, and the front cover. then reassemble the drive.

3-3 Wiring

CAUTION

- Check the wiring again before operating the drive. Improper wiring may cause unexpected drive operation or device operation. **There is a risk of accident or injury.**

Wiring the option and PG

- Use a shielded cable for wiring the drive option, keeping the wiring length to within 328 feet (100m).
- Connect the sheath of the shielded cable to terminal G of the drive, leaving the other end open.
- Run the option wiring at least 4 inches (10 cm) from the main circuit wiring of the drive main unit and other power cables to avoid abnormal operation due to electrical noise. Do not run the option wiring in the same electrical duct with any other power cables.

Terminal Connection on Option

The wire size for the option connection terminal is AWG: 16-26. When an unshielded connection terminal is used, make the length of the unshielded wire ¼ inch (6 mm). When using a crimp terminal, be sure to use an insulated ferrule. Insert the wire into the upper side of the metal bracket on the terminal block, and tighten the screw.

Wiring AWG: 16 to 26

1/4 inch (6 mm)

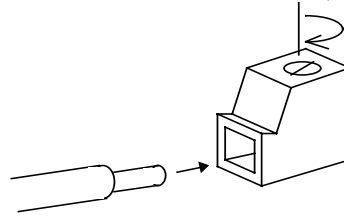

Figure 3-3-1 Wire Terminal on Option
Connection Terminal Side

Figure 3-3-2 Connection of Wiring on Optional
Terminal Side

3-4 Applicable PG

The PG specifications that can be applied to the drive option are listed in table 3-4-1.

Table 3-4-1 Specifications of Applicable PG.

Item		Specifications
Applicable PG	Output Pulse	20 to 3000P/R
	PG Power Supply	+5VDC± 10% / 200mA
	Maximum Response Frequency	100kHz
	Pulse Output System	AM26LS31
PG Power Supply	Internal Power Supply	+5VDC± 10% / 200mA(*1)
	External Power Supply	5VDC± 10%

*1) Please use an external power supply when load exceeds 200mA.

PG Installation and Signal

Forward motor running is counterclockwise rotation viewed from the drive side. (see Figure 3-4-1) In forward running, the PG output pulse is the forward signal, shown in Figure 3-4-2. (phase B signal advances by 90 degree from phase A signal) In reverse running, the PG output pulse is the reverse signal, shown in Figure 3-4-2. (phase A signal advances by 90 degree from phase B signal). Connect the PG directly to the motor using a coupling.

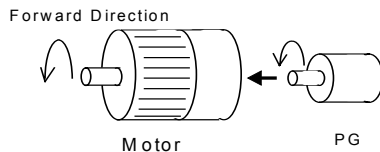

Figure 3-4-1 Motor and PG Forward Direction.

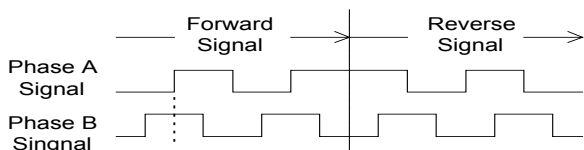

Figure 3-4-2 PG signals.

4 Option Power Supply Settings

CAUTION

- Set the option power supply so that it matches the PG power voltage or pulse oscillator voltage.

There is a risk of failure.

4-1 Option Power Supply Settings

Before applying power to the drive, set jumper J1 on the PG power supply.

4-1-1 Setup of Jumper J1 (Switching between the drive internal power supply and an external power supply)

Jumper J1 is used to set the PG power supply. See Table 4-1-1 and Figure 4-1-1 to set the power supply.

Table 4-1-1 Setting Jumper J1

Power Supply Used	Jumper Setting
Internal Power Supply	Use the switching cap to connect the INT side of jumper J1.
External Power Supply	Use the switching cap to connect the EXT side of jumper J1. Please connect the power supply of $+5V_{dc} \pm 10\%$ with terminal PI.

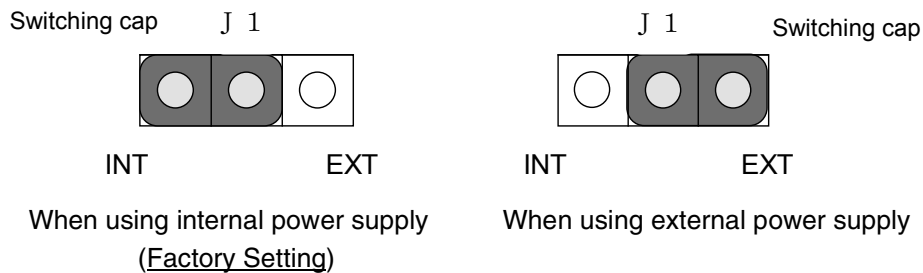

Figure 4-1-1 Jumper J1 setting

5 PG Vector Control

The PG feedback signals are used to control the PG vector.

5-1 Basic Connection Diagram

Figure 5-1-1 shows the connection example when PG vector control is used.

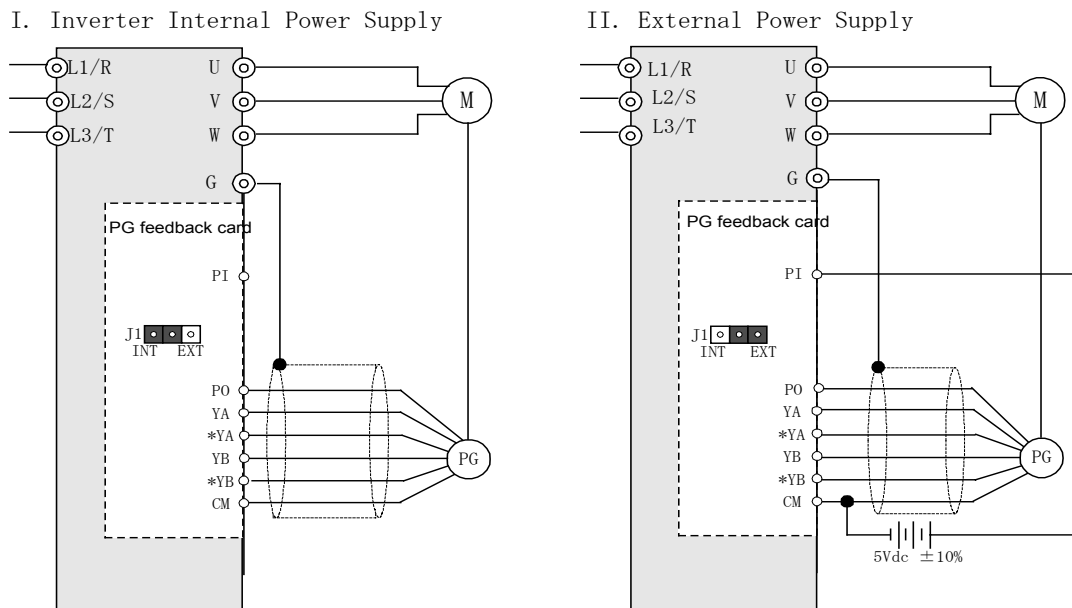

Figure 5-1-1 Connection diagram when PG vector control is used.

5-2 Terminal Functions

Terminal Arrangement

PI	PO	XA	XB	XZ	PO	YA	YB	YZ	
	CM	CM	*XA	*XB	*XZ	CM	*YA	*YB	*YZ

Table 5-2-1 Terminal functions When PG Vector Control Is Used.

Terminal Strip	Terminal Name	Function
Option Card Side	PI	PG External Power Supply Input Supplies PG power from external power supply.
	PO	PG Power Supply Output Outputs power to PG.
	CM	Common PG power supply common terminal
	YA	Input of Feedback PG Phase-A (+) Pulse Connects feedback PG phase A (+) signal.
	*YA	Input of Feedback PG Phase-A (-) Pulse Connects feedback PG phase A (-) signal.
	YB	Input of Feedback PG Phase-B (+) Pulse Connects feedback PG phase B (+) signal.
	*YB	Input of Feedback PG Phase-B (-) Pulse Connects feedback PG phase B (-) signal.
		Terminals YZ/*YZ/XA/*XA/XB/*XB/XZ/*XZ Do not use.
Drive Side	X Terminal	(*)

(*) PG Feedback Command FUNCTION

When "27: SY/PG control selection [PG/Hz]" is set as the data of function codes E01 to E09, the PG option (speed feedback control) can be canceled with terminals from X1 to X9 (effective when the unit's digit of o01 is set to 1).

Note that this ON or OFF command is not effective during operation and becomes effective after the drive stops.

When terminals X1 to X9 are not allocated for PG/Hz, speed feedback control is always effective.

Table 5-2-2 Terminal Function.

PG/Hz " 27 "	Function
ON	With speed feedback control
OFF	Speed feedback control canceled

(*) ZERO SPEED COMMAND FUNCTION

Zero speed command function is to maintain torque at zero speed, when PG vector control is used.

When "29: ZERO speed command selection [ZERO]" is set as the data of function codes E01 to E09, Zero speed torque can be used with terminals from X1 to X9 (effective when the unit's digit of o01 is set to 1).

Table 5-2-3 Terminal Function.

ZERO " 29 "	Function
ON	With zero speed command
OFF	zero speed command canceled

(*) PRE-EXCITATION COMMAND FUNCTION

Pre-excitation command function is to improve starting characteristics by exciting the motor before the drive .

Pre- excitation function is canceled ,while driving a motor.

When "32: Pre-excitation command [EXITE]" is set as the data of function codes E01 to E09, pre-excitation function can be used with terminals from X1 to X9 (effective when the unit's digit of o01 is set to 1).

DC braking function takes precedence over pre-excitation function. You should set the sequence that pre-excitation starts before driving a motor and that pre-excitation stops before stopping a motor.

Table 5-2-4 Terminal Function.

EXITE " 32 "	Function
ON	With pre-excitation command
OFF	pre-excitation command canceled

5-3 Function Codes

Parameters related to PG vector control is listed in Table 5-3-1.

Table 5-3-1 Function Code.

Func No.	Name	Setting Range	Unit	Min. Unit	Factory Setting	Change during operation
F03	Maximum frequency 1	50 to 400Hz	Hz	1	60	x
F04	Base frequency 1	25 to 400Hz	Hz	1	60	x
F05	Rated voltage 1	0V: Outputs voltage proportion to input voltage. 80 to 240V : 230V class 320 to 480V : 460V class	V	1	230/460	x
F40	Torque limiter 1 (Driving)	20 to 200% ,999% (No limit)	%	1	999	O
F41	Torque limiter 1 (Braking)	0% (Automatic deceleration control) 20 to 150% ,999% (No limit)	%	1	999	O
E16	Torque limiter 2 (Driving)	20 to 200% ,999% (No limit)	%	1	999	O
E17	Torque limiter 2 (Braking)	0% (Automatic deceleration control), 20 to 150% ,999% (No limit)	%	1	999	O
E01 ~ E09	Terminal X function	27: SY/PG control selection 29: ZERO speed command selection 32: Pre-excitation command	- - -	- - -	- - -	x x x
P01	Motor 1 (Number of poles)	2 to 14	Pole	2	4	x
P02	(Capacity)	22kW or less :0.01 to 45.00kW 30kW or more :0.01 to 500.00kW	kW	0.01	Typical value of standard motor	x
P03	(Rated current)	0.00 to 2000A	A	0.01	Typical value of standard motor	x
P05	(On-line tuning)	0 : Inactive 1 : Active	-	-	0	x
P06	(No-load current)	0.00 to 2000A	A	0.01	Typical value of standard motor	x
P07	(%R1)	0.00 to 50.00%	%	0.01	Typical value of standard motor	O
P08	(%X)	0.00 to 50.00%	%	0.01	Typical value of standard motor	O
P09	(Slip compensation control 1)	0.00 to 5.00Hz	Hz	0.01	Typical value of standard motor	O
H18	Torque control	0, 1, 2	-	-	0	x
H28	Droop control	-9.9 to 0.0Hz	Hz	0.1	0.0	O
o01	Speed command system / automatic speed control system	00 ,01 ,10 ,11 ,20 ,21	-	-	00	x
o02	Time constant of PG vector and speed command filter	0.000 to 5.000	s	0.001	0.02	O
o03	Number of feedback PG pulses	20 to 3000	p	1	1024	x
o04	Constant P of feedback speed controller	0.01 to 200.00	Times	0.01	10.00	O
o05	Constant I of feedback speed controller	0.000 to 5.000	s	0.001	0.100	O
o06	Time constant of feedback speed detection filter	0.000 to 5.000	s	0.001	0.005	O
o07	Feedback pulse correction coefficient 1	1 to 10000	-	1	1	x
o08	Feedback pulse correction coefficient 2	1 to 10000	-	1	1	x

5-4 PG Polarity

Figure 5-4-1 shows the PG polarity. See Section 3-4, "Applicable PG," for details about forward and reverse motor directions and the PG.

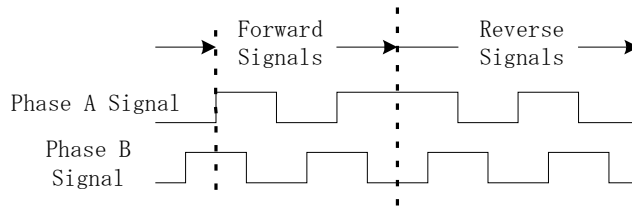

Figure 5-4-1 PG Signals.

5-5 Function Code Settings

WARNING

•Check and adjust parameters before operation. Improper parameters may cause an unexpected operation for some devices. **There is a risk of accident.**

To perform PG vector control, the function codes below must be set. Set the function codes according to the procedure below. Operating the drive without setting function codes may cause unexpected drive or device operation.

Before Option Function Settings (Motor Parameters Setting)

Setting function codes F, P, and A

Set function codes F03 (*1), F04, F05, P01, P02, P03, P06, P07, P08, and P09 according to the VG10 User's Guide. When using a second motor, set function codes A01, A02, A03, A10, A11, A12, A15, A16, A17, and A18 according to the VG10 User's Guide.

*1) Function codes o04 and o05 must be readjusted when the value of function code F03 is changed.

Option Function Settings

Speed Command System and Automatic Speed Control System Selection

- Function code o01: The unit's digit of o01 selects the speed command system.
The ten's digit of o01 selects the automatic speed control system.

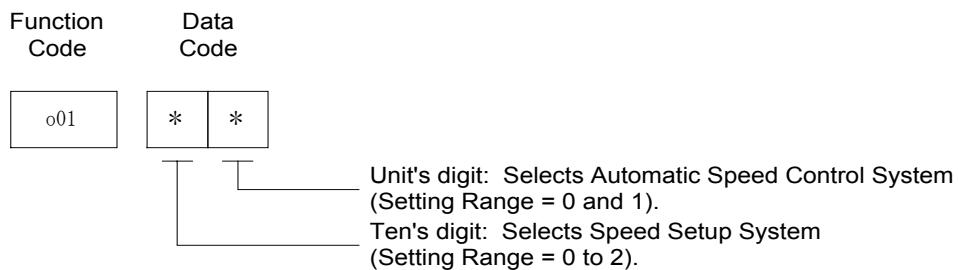

Table 5-5-1 Function Codes.

Function code			Function
o01	Unit's Digit	0	Without speed feedback control
	Unit's Digit	1	PG vector control
	Ten's Digit	0	Without pulse train input
	Ten's Digit	1	Phase A or phase B pulse train input
	Ten's Digit	2	Phase B pulse train input

- Function code o02: Sets the time constants of primary delay filter for the speed setting. This code is used to suppress overshoot when speed commands are changed.
- Function code o03: Sets the number of feedback PG pulses.
- Function code o04: Sets constant P of the feedback speed controller. (*1)
- Function code o05: Sets constant I of the feedback speed controller. (*1)

The transfer function of the speed controller is expressed as follows:
$$\tau^* = k_p \left(1 + \frac{1}{sT_I} \right) \times \varepsilon$$

K_p : Constant P
 T_I : Constant I
 τ* : Torque command
 ε : Speed deviation

When speed deviation ε = 100%, Constant P (for torque command τ* = 100%) is assumed to be 1.

- Function code o06: Sets the time constants of primary delay filter for the speed detection value. This code is used to suppress the large ripple in the speed detection signal.
 Set function code o07 and o08 for a motor equipped with speed reducer.
- Function code o07: Sets pulse compensation coefficient 1. (*2)
- Function code o08: Sets pulse compensation coefficient 2. (*2)

(*1) Function codes o04 and o05 must be readjusted when the value of function code F03 is changed.

(*2) Set a value of $\frac{o08}{o07}$ to 1 or more. Any value less than 1 is treated as 1.

Reference

PG Vector Control Setting Procedure

Set function codes o02: 0.02 (s), o04: 10 (times), o05: 0.1 (s), and o06: 0.005 (s). See the setting procedure for constants P (o04) and I (o05) below to adjust stability and response. Adjusting constants with function codes o02 (time constant of speed command filter) and o06 (time constant of feedback speed filter) can also improve stability and response.

Constant P (o04)

Constant P (o04) is a parameter used to determine response speed for any deviation in proportion operation. Specifying a larger value for constant P enables a quicker response. Specifying a value that is too large results in an oscillating (hunting) response. Specifying a smaller value for constant P slows the response.

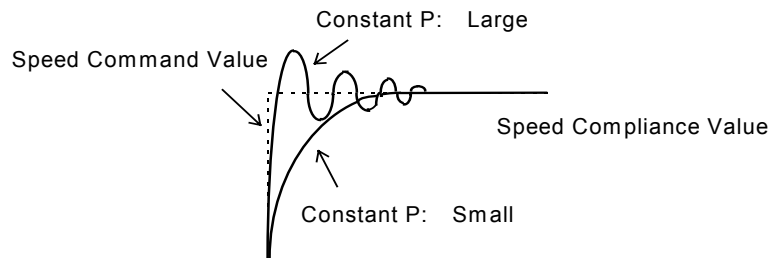

Figure 5-5-1 Response When Constant P Adjusted.

Constant I (o05)

Specifying a larger value for constant I (o05) slows the response and weakens the reaction to external force. Specifying a smaller value for constant I (o05) enables a quicker response. Specifying a value that is too small results in an unstable oscillating (hunting) response. Vibration in a larger cycle than constant I (o05) can be suppressed.

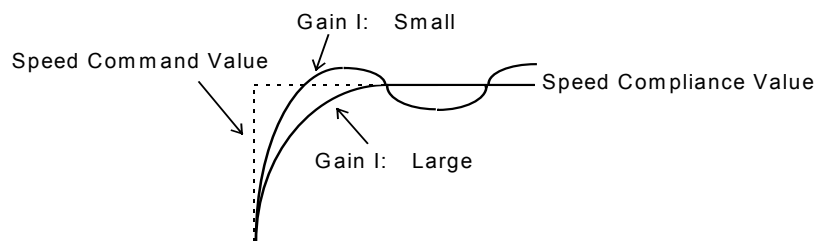

Figure 5-5-2 Response When Gain I Adjusted.

5-6 Notes on use

WARNING

•Check the parameters and wiring before operation. Improper parameters or wiring may cause an unexpected operation for some devices. **There is a risk of accident.**

Carrier Frequency

Set the carrier frequency (F26) more than 5(kHz) to suppress the hunting , when using PG vector control.

Electronic Thermal Overload Relay Protection

Prevent motor overheating by using the electronic thermal overload relay function when PG vector control is used. See the drive User's Guide for details of the electronic thermal overload relay setup.

When Torque Control Used

When PG vector control and torque control are used concurrently, a line power interruption may not be detected depending on the load state. In this case, input the line power interruption signal at any X1 through X9 terminal that is not in use. Set the corresponding function code E01 through E09 to 7 to stop the drive. Figure 5-6-1 shows an example of the connection.

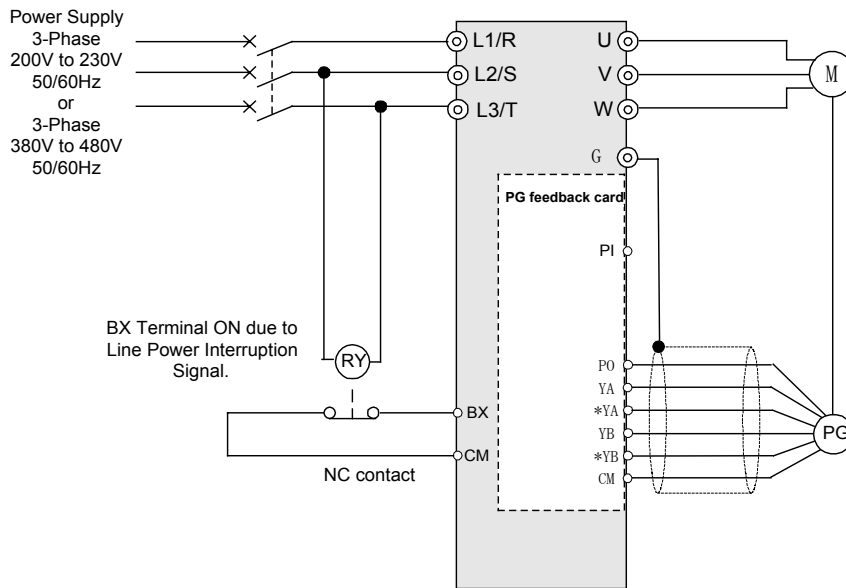

Figure 5-6-1 Recommended Circuit When Torque Control Used.

5-7 Control Specifications

Table 5-7-1 Control Specifications.

Item	Control Specifications	Remarks
Speed Control Range	3 to 3600 [rpm] (for 4-pole motor)	-
Speed Control Accuracy	±0.02%	
Starting Torque	150% / zero-speed (at ZERO signal ON) short time	
Maximum Number of Input Pulse	100(kp/s)	

5-8 Function Codes (Specifications when PG vector Control is Used)

The functions that differ from the standard specifications are listed as follows, when PG vector control is used.

List of Functions when PG Vector Control is Used

F: Fundamental Functions

Func.	Function Name	LCD Display	Setting Range	Units	Spec. when PG Vector Mode
F03	Max. Frequency 1	F03 MAX_Hz-1	50 to 400Hz	Hz.	Note: 120hz is limit in PG Vector Mode.
F05	Rated Voltage 1 (at base frequency)	F05 Rated_V-1	0V: Output Voltage proportion to input voltage	V.	Set to 0V for AVR operation
F06	Max. Voltage 1 (at Max. Freq. 1)	F06 Max V-1	80 to 240V (230 unit) 320 to 480V (460 unit)	V.	Invalid in Vector Mode
F09	Torque Boost 1	F09 TRQ Boost 1	0 to 20	-	Invalid in Vector Mode
F15	Freq. Limit(High)	F15 H LIMITER	0 to 400Hz.	Hz.	Note: 120hz is limit in PG Vector Mode.
F20	DCBrake Start Freq.	F20 DC BRK Hz	0 to 60Hz.	Hz.	DC inj. Braking operates when the run command is off and the output frequency is equal to or less than the start freq.
F21	DC Braking Level	F21 DC BRK LVL	0 to 100%	%	
F22	DC Braking Time	F22 DC BRK t	0 to 30 Seconds	S	
F31	FMA Function	F31 FMA FUNC	0 = Output Freq.(before slip) 1 = Output Freq.(after slip) 2 = Output Current 3 = Output Voltage 4 = Output Torque 5 = Load Factor 6 = Input Power 7 = PID feedback 8 = PG feedback		0 = ASR setting Value 1 = Output Freq. 2 = Output Current 3 = Output Voltage 4 = ASR output or torque command 5 = ASR output or torque command 6 = Input Power 7 = PID feedback 8 = Speed Detection Value
F35	FMP Function	F35 FMP FUNC	0 = Output Freq.(before slip) 1 = Output Freq.(after slip) 2 = Output Current 3 = Output Voltage 4 = Output Torque 5 = Load Factor 6 = Input Power 7 = PID feedback 8 = PG feedback		0 = ASR setting Value 1 = Output Freq. 2 = Output Current 3 = Output Voltage 4 = ASR output or torque command 5 = ASR output or torque command 6 = Input Power 7 = PID feedback 8 = Speed Detectiopn Value
F40	TRQ Limiter (DRV)	F40 DRV TRQ 1	20 to 200% 999 disable	%	200% when 999 is set
F41	TRQ Limiter (BRK)	F41 BRK TRQ 1	20 to 200% 999 disable	%	200% when 999 is set
F42	TRQ Vector Control	F42 TRQVECTOR	0 - 1		set to 1 for PG Vector Mode

E: Extension Terminal Functions

Func.	Function Name	LCD Display	Setting Range	Units	Spec. when PG. Vector Mode
E01	X1 Term. Function	E01 X1 FUNC	0 = Multi-step Freq.		0 = Multi-step Freq.
E02	X2 Term. Function	E02 X2 FUNC	1 = Multi-step Freq.		1 = Multi-step Freq.
E03	X3 Term. Function	E03 X3 FUNC	2 = Multi-step Freq.		2 = Multi-step Freq.
E04	X4 Term. Function	E04 X4 FUNC	3 = Multi-step Freq.		3 = Multi-step Freq.
E05	X5 Term. Function	E05 X5 FUNC	4= ACC/DEC time 1		4= ACC/DEC time 1
E06	X6 Term. Function	E06 X6 FUNC	5= ACC/DEC time 2		5= ACC/DEC time 2
E07	X7 Term. Function	E07 X7 FUNC	6= 3-wire Start/Stop		6= 3-wire Start/Stop
E08	X8 Term. Function	E08 X8 FUNC	7= Coast to Stop		7= Coast to Stop
E09	X9 Term. Function	E09 X9 FUNC	8= Alarm reset		8= Alarm reset
			9= Trip Command(OH2)		9= Trip Command(OH2)
			10= Jog Operation		10= Jog Operation
			11= Freq. 1 to Freq. 2		11= Freq. 1 to Freq. 2
			12= Motor2/Motor1		12= Motor2/Motor1
			13= DC Brake Command		13= DC Brake Command
			14= Trq limiter1/Limiter2		14= Trq limiter1/Limiter2
			15= Switch Line to Drive/50Hz		15= detects motor speed/switch to line
			16= Switch Line to Drive/60Hz		16= detects motor speed/switch to line
			17= Up Command		17= Up Command
			18= Down Command		18= Down Command
			19= Disable changing Func,		19= Disable changing Func,
			20= PID Cancel		20= PID Cancel
			21= Inverse Mode Select		21= Inverse Mode Select
			22= Interlock		22= Interlock
			23= TRQ Control Cancel		23= TRQ Control Cancel
			24= Serial Link enable		24= Serial Link enable
			25= Universal DI		25= Universal DI
			26= Pickup Start Mode		26= Pickup Start Mode
			27= SY-PG enable		27= Cancel Speed Feedback control
			29= Zero Speed Command		29= Zero Speed Comm.(PG. Vector)
			30= Alarm Stop		30= Alarm Stop
			31= Alarm Stop dec4		31= Alarm Stop dec4
			32= Pre-exciting Command		32= Pre-exciting Command(PG. vector)

E : Extension Terminal Functions

E20	Y1Term. Function	E20 Y1 FUNC	0 = Drive Running		0 = Drive Running
E21	Y2Term. Function	E21 Y2 FUNC	1= Freq. arrival Det.		1= Freq. arrival Det.
E22	Y3Term. Function	E22 Y3 FUNC	2= Freq. Level Det.		2= Freq. Level Det.
E23	Y4Term. Function	E23 Y4 FUNC	3= Under-voltage Det.		3= Under-voltage Det.
E24	Y5a/Y5cTerm. Func	E24 Y5 FUNC	4= TRQ Polarity(BRK/DRV)		4= ASR Output
			5= TRQ Limiting		5= ASR output limit
			6= Auto-Restarting		6= Auto-Restarting
			7= Overload early Warning		7= Overload early Warning
			8= Keypad Operation		8= Keypad Operation
			9= Drive Stopping		9= Drive Stopping
			10= Ready Output		10= Ready Output
			11= Line/INV Changeover		11= Line/INV Changeover
			12= Line/INV Changeover		12= Line/INV Changeover
			13= Line/INV Changeover		13= Line/INV Changeover
			14= Motor 2/Motor 1		14= Motor 2/Motor 1
			15= Terminal AX Function		15= Terminal AX Function
			16= Patt. Oper. Completed		16= Patt. Oper. Completed
			17= Patt. Oper Cycle		17= Patt. Oper Cycle
			18= Patt. Stage 1		18= Patt. Stage 1
			19= Patt. Stage 2		19= Patt. Stage 2
			20= Patt. Stage 4		20= Patt. Stage 4
			21= Alarm Indication 1		21= Alarm Indication 1
			22= Alarm Indication 2		22= Alarm Indication 2
			23= Alarm Indication 4		23= Alarm Indication 4
			24= Alarm Indication 8		24= Alarm Indication 8
			25= Fan Operating Signal		25= Fan Operating Signal
			26= Auto-resetting		26= Auto-resetting
E30	FAR function(HYS)	E30 FAR HYSTR	0.0 to 10Hz	Hz	According to Actual Motor Speed
E31	FDT Signal Level	E31 FDT1 LEVEL	0 to 400Hz	Hz	According to Actual Motor Speed
E32	FDT Hystersis	E32 FDT HYSTR	0.0 to 300Hz	Hz	According to Actual Motor Speed
E40	Display Coe. A	E40 COEF A	(-)999.00 to 999.00		Coefficient for Motor Speed
E41	Display Coe. B	E41 COEF B	(-)999.00 to 999.00		Coefficient for Motor Speed

C: Control Functions of Frequency

Func.	Function Name	LCD Display	Setting Range	Units	Spec. when PG. Vector Mode
C05	Multi-step Freq.	C05 MULTI HZ-1	0 to 400Hz	Hz	Limit is 120hz with PG. feedback
C20	Jog Frequency	C20 JOG HZ	0 to 400Hz	Hz	Limit is 120hz with PG. feedback

H: High Performance Functions

Func.	Function Name	LCD Display	Setting Range	Units	Spec. when PG. Vector Mode
H09	Start Mode	H09 START MOD	0 : Inactive		0 : Inactive(active at auto-restart)
			1 : Active		1 : Active
			2 : Active		2 : Active
H10	Energy Saving	H10 ENERGY SA	0 : Inactive		Invalid in PG. Vector Mode
			1 : Active		

A: Alternative Motor Parameters

Func.	Function Name	LCD Display	Setting Range	Units	Spec. when PG. Vector Mode
A01	Max. Frequency 2	A01 MAX_Hz-2	50 to 400Hz	Hz.	Note: 120hz is limit in PG. Vector Mode.
A02	Base Frequency 2	A02 BASE Hz-2	25 to 400Hz	Hz.	Note: 120hz is limit in PG. Vector Mode.
A03	Rated Voltage 2	A03 Rated_V-2	0V: Output Voltage	V.	Set to 0V for AVR operation
	(at base frequency)		proportion to input voltage		
A04	Max. Voltage 2	A04 Max V-2	80 to 240V (230 unit)	V.	Invalid in Vector Mode
	(at Max. Freq. 2)		320 to 480V (460 unit)		
A05	Torque Boost 2	A05 TRQ Boost 2	0 to 20	-	Invalid in Vector Mode

6 Additional Information

6-1 Alarm Protection Function

When the drive protection function is activated, the drive is immediately tripped, an alarm is displayed on the keypad panel LED, and the motor coasts to a stop. If this protection function is activated, remove the cause of the trip, then restart the drive. Do not use an external sequence to automatically reset the alarm. See Table 7-1-1 for details about tripping related to this option. For other types of tripping, see "Protective operations" regarding the drive main unit.

Table 7-1-1 List of Alarm Protection Functions.

Trip Display	30ABC	Cause of Trip
OS	ON	1.Overspeed error : Displays an error if detection speed exceeds the [minimum setup value from 120 [Hz], F03 (A01), and F15] by 1.2 times. 2.Overspeed error : Displays an error when trains specification of applicable PG is not satisfied.
PG	ON	1.PG disconnection error : Judges feedback disconnection and displays an error.

6-2 I/O Check

The digital input status of the PG option can be checked on the drive keypad panel. Switch from the run mode screen to the program menu screen, then select 4, [I/O check]. The I/O check monitor has seven screens. Using the up and down keys, scroll through the screens to check the digital input status of the PG option. See the explanation of how to operate the keypad panel in Section 4 of the Drive User's Guide.

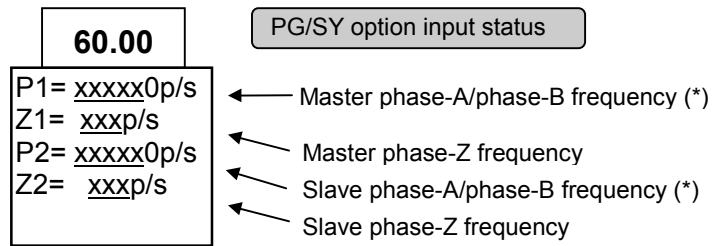

(*) A drive with a Drive ROM version number G11S05000 displays the frequency multiplied by four.