



[www.saftronics.com](http://www.saftronics.com)

**dcM6+ & dcM12+  
ES800 Control Board and  
IC U11 Replacement Manual**

**Saftronics, Inc.**

5580 Enterprise Pkwy., Ft. Myers, FL 33905

Telephone: (941) 693-7200

Fax: (941) 693-2431

[www.saftronics.com](http://www.saftronics.com)

BOARD P/N ES800-X

DOC. NO. 027-2116

# **SAFETY FIRST !**

*LETHAL VOLTAGES MAY BE PRESENT!*

PLEASE READ THIS INSTRUCTION MANUAL THOROUGHLY BEFORE ATTEMPTING ANY INSTALLATION, OPERATION, MAINTENANCE OR INSPECTION. FAILURE TO FOLLOW THE RECOMMENDED PROCEDURES OR CAUTIONS IN THIS MANUAL COULD RESULT IN INJURY TO PERSONNEL AND/OR DAMAGE TO EQUIPMENT.

## **CAUTION !**

1. CHECK THE NAME WRITTEN ON THE PRODUCTS AND INSURE THAT THE PROPER PART HAS BEEN RECEIVED.
2. THOROUGHLY INSPECT THE PART(S) FOR ANY DAMAGE DUE TO SHIPMENT OR HANDLING.
3. THE PART(S) MAY CONTAIN CMOS CHIPS AND CAN BE DAMAGED BY STATIC ELECTRICITY. HANDLING SHOULD BE IN ACCORDANCE WITH INDUSTRY STANDARDS.
4. BEFORE INSTALLING THE PART(S) TURN OFF ALL POWER TO THE EQUIPMENT. **LETHAL VOLTAGES ARE PRESENT !**
5. DO NOT CONNECT OR DISCONNECT WIRING WHILE POWER IS **ON!**
6. FOLLOW GOOD STANDARD WIRING PRACTICES AND ANY APPLICABLE CODES THAT MAY APPLY.

## **Introduction**

When replacing the Control Board for the dcM6+ or dcM12+ Drive it is recommended that the non-volatile memory chip IC U11 be transferred from the “old” board to the replacement board so that the original factory programmed parameters are preserved. If this is not done then significant programming steps will be required which is both time consuming and error prone. In the case that IC U11 is damaged, please consult factory before proceeding. When handling IC U11 maintain good practices as set forth by industry standards avoiding static electricity and mechanical damage.

## **Replacement Procedure**

The following tools will be required to disassemble and replace the control board and IC U11.

- flat blade screwdriver
- small bladed screwdriver
- needle nose pliers
- IC puller (optional)

*REFERRING TO FIGURE 1:*

## **Disassembly**

- 1- Remove Terminal Cover with (2) screws.
- 2- Remove Main Cover with (4) screws.
- 3- Remove Keypad Retainer with (1) screw.
- 4- Remove Keypad by inserting a small bladed screwdriver as per instructions on Keypad.
- 5- Remove Keypad Mounting Plate from stand-offs with (4) screws and washers.
- 6- *IC U11 should now be visible on the Control Board and should be removed at this time and saved. **Proceed with CAUTION as this component can be easily damaged if not handled properly.*** An IC puller is preferred but if one is not available, using a small bladed screwdriver, slide the blade under one end of the IC above the socket and gently pry. Do not try to remove the IC completely. Then go to the other end and repeat. Alternate this procedure until the IC is loose and can easily be removed. After removal inspect the IC to insure that there is no damage and the pins have not been bent. Put the IC in a plastic container as it will be assembled in the new Control Board.
- 7- Disconnect (3) cables connected to CN1, CN2, and CN3.

- 8- Remove (1) mounting screw from the Interface Board.
- 9- The Control Board and Interface Board are held by plastic mounting clips to the chassis. Using a pair of needle nose pliers, gently squeeze each clip across the rib and at the same time pull up on the board so that it is free of the clip. There are (4) clips on the Control Board and (1) on the Interface Board.
- 10 & 11- Once the boards are free from the chassis, they may be separated at connectors CN1(Interface Board) and CN10 (Control Board), and the Control Board completely removed. NOTE: The connections to the Interface Board 11 terminal block do not need to be removed unless this board is also being replaced.

## **Re-Assembly**

Connect the new Control Board 10 CN10 to the Interface Board 11 CN1 and place over the plastic locking clips 9 on the chassis. Gently push down on each clip until the board(s) is seated at the bottom of clip. Assemble mounting screw 8 to Interface Board.

Using the procedure previously described, remove IC U116 and put aside. Insert the IC removed from the “old” Control Board by gently pushing into the socket making sure that the pins are aligned and properly seated.

***NOTE: INSURE THAT THE NOTCH ON THE IC IS ORIENTED PROPERLY AS SHOWN IN FIGURE 1 (6).***

Reconnect (3) cables 7 and insure they are properly seated. Replace Keypad Mounting Plate 5 with (4) screws and washers. Align Keypad 4 and connecting cable and push into Mounting Plate making sure the Keypad connecting cable is properly seated. Replace Keypad Retainer 3 then Main Cover 2 and finally Terminal Cover 1.

***CHECK ALL CONNECTIONS FOR INTEGRITY BEFORE APPLYING POWER.***

# DISCONNECT ALL POWER BEFORE PROCEEDING !

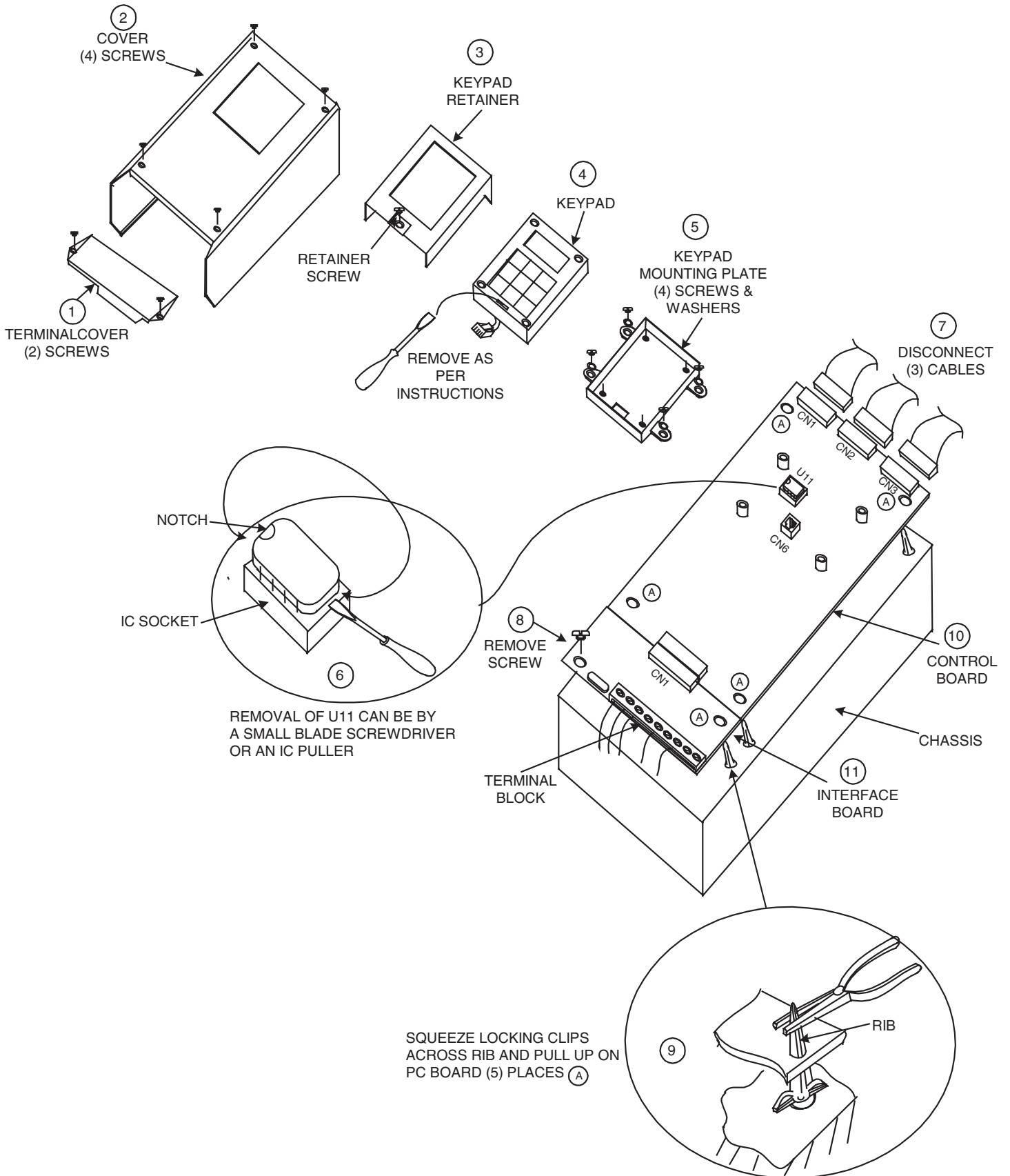

Fig. 1 dcM6/12+ CONTROL BOARD AND IC U11 REPLACEMENT

## **WARNING!**

*Saftronics* manufactures component parts that can be used in a wide variety of industrial applications. The selection and application of *Saftronics* products remains the responsibility of the equipment designer or end user. *Saftronics* accepts no responsibility for how its products may be incorporated into the final design.

Under no circumstances should any *Saftronics* product be incorporated into any product or design as the exclusive or sole safety control. Without exception, all controls should be designed to dynamically fault detect and fail safe under all circumstances. All products designed to incorporate a component part manufactured by *Saftronics*, must be supplied to the end user with appropriate warnings and instructions as to the safe use and operation. Any warnings provided by *Saftronics* must be passed through to the end user.

*Saftronics* offers an express warranty only as to the quality of its products to conform to the catalog specifications. NO OTHER WARRANTY, EXPRESS OR IMPLIED, IS OFFERED. *Saftronics* assumes no liability for any personal injury, property damage, losses or claims, arising out of the misapplication of its products.