



# DG2 PLUS SERIES

¼ to 5 HP

SCR Speed Controls  
for DC Motors

## CAUTION

Equipment is at possibly lethal AC line voltage when AC power is connected. Pressing the STOP pushbutton does not remove AC line voltage. Both phases must be disconnected before it is safe to touch motor terminals or control equipment parts.

### **Saftronics, Inc.**

5580 Enterprise Pkwy., Ft. Myers, FL 33905

Telephone: (941) 693-7200

Fax: (941) 693-2431

P/N X010031

Rev: 5

# DG2 PLUS

## INSTRUCTION MANUAL

### CONTENTS

#### Section 1.0: Description

1.1	Overview .....	1
1.2	Standard Features .....	1

#### Section 2.0: Specifications

2.1	Electrical .....	2
2.2	Electrical protection .....	3
2.3	Mechanical .....	3
2.4	Adjustments .....	3

#### Section 3.0: Receiving & Installation

3.1	Installation .....	4
3.2	Derating data .....	4
3.3	Wiring .....	4

#### Section 4.0: Startup

4.1	Inspection .....	5
4.2	Pre-start adjustments .....	5
4.3	Starting .....	6

#### Section 5.0: Troubleshooting

.....	7
-------	---

#### Section 6.0: Wiring diagrams

6.1	DG2P-10 & DG2P-15 .....	8
6.2	DG2P-25 .....	9
6.3	Typical torque control connection .....	10
6.4	AA1128 Control card schematic .....	11
6.5	Motor connections .....	12

#### Section 7.0: Dimensional outlines

7.1	DGP2-10 & DG2P-15 .....	13
7.2	DG2P-25 .....	14
7.3	Enclosed .....	15

#### Section 8.0: Spare parts

.....	16
-------	----

#### Section 9.0: Warranty

.....	17
-------	----

## 1.0 DESCRIPTION

**1.1 Overview** DG2 PLUS series non-regenerative two quadrant thyristor controllers are designed to control the speed of wound field or permanent magnet dc motors from ¼ to 5 hp. These drives can also be modified to become torque control regulators.

- Control block diagram

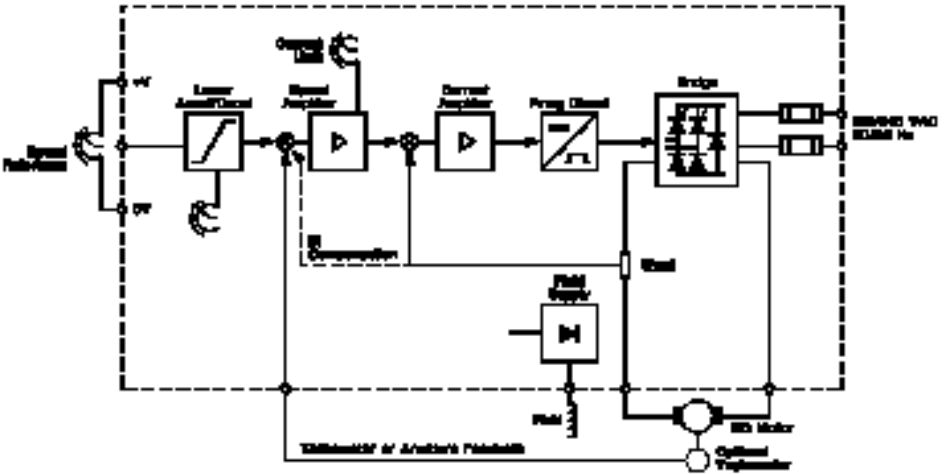

- 1.2 Standard Features**
- **Impedance-isolated armature voltage feedback**  
High impedance resistive voltage divider network used for armature voltage feedback.
  - **Tachogenerator feedback**  
50 volt/1000 rpm tachometers may be used for speed feedback.
  - **Dual AC line voltage**  
120 or 240 vac line voltages are plug selectable.
  - **Dual field voltage**  
50/100 or 100/200 volt field supplies are link selectable.
  - **10V reference supply**
  - **LED indication**  
Run relay energized  
Power "ON"

# SAFTRONICS

## 2.0 SPECIFICATIONS

- 2.1 Electrical**
- **Power**  
Single phase 120 or 240 vac, 50/60 Hz., ( $\pm 10\%$ ).
  - **Speed range**  
10:1 with armature feedback, 50:1 with tachometer feedback.
  - **Load regulation**  
 $\pm 3\%$  with armature voltage, ( $\pm 10\%$  line voltage change).
  - **Acceleration/Deceleration**  
Adjustable: 0.1-30 seconds from 0 to full speed.
  - **Temperature range**  
32°F - 104°F (0-40°C).
  - **Altitude**  
2000 feet (600m) maximum without derating.
  - **Rectifier configuration**  
The DG2 PLUS employs a single phase, half-wave bridge.
  - **HP & Current rating**

MODEL	HP		AMPS	
	120 VAC	240 VAC	INPUT	OUTPUT
DG2P-10	1	2	18	10
DG2P-15	-	3	25	15
DG2P-25	-	5	34	25

- **Voltage rating (selectable via JMP1, see P.5.)**

INPUT	OUTPUT VDC	
	ARMATURE	FIELD
120 VAC	0-90	50/100
240 VAC	0-180	100/200

- **Short circuit rating**  
Suitable for use on a circuit capable of delivering not more than 5000 rms symmetrical amperes, 240 V maximum.

- 2.2 Electrical Protection
- **Fusing**  
One fast-acting fuse in each AC leg.
  - **Current limit**  
Adjustable current limit circuit 0 - 125%.
  - **Surge suppression**  
MOV surge suppressor.

2.3 Mechanical For dimensional information see page 13.

- 2.4 Adjustments
- **RV1 Acceleration**  
This control adjusts both acceleration and deceleration time. In the fully clockwise position, acceleration/deceleration time is 0.1 seconds, and in the fully counter-clockwise position, acceleration/deceleration time is 30 seconds.
  - **RV2 Current stability**  
This control, which has been factory preset, adjusts the stability of the current loop.
  - **RV3 Voltage stability**  
This is factory preset and very seldom needs adjustment. If the motor should hunt, rotate this trimpot until the motor runs smoothly. The normal position of this trimpot is approximately 1/5 turn clockwise.

**CAUTION:** *Adjusting RV4 to over 50% clockwise rotation, may cause drive instability which cannot be corrected by RV3 voltage stability. In such a case, back off slightly from the position where RV4 causes instability. This may result in a slight decrease in speed holding.*

- **RV4 IR Compensaion**  
Factory set to CCW for Tach Feedback, this control rarely needs to be used. However, when using armature voltage feedback with cyclical loading applications where there is a speed drop due to operation from high to low load, the "IR Comp" adjustment corrects for voltage changes inside the DC motor when load is applied. If speed variations with load are a problem, set the "SPEED" control knob to the desired operating speed. Now load the drive. Adjust RV4 until the motor speed returns to its unloaded speed. Remove the load and ensure motor speed is stable.
- **RV5 Current limit**  
This control is preset at factory and seldom needs field adjustment.
- **RV6 Maximum speed**  
This adjustment is used to set the maximum armature voltage or motor speed.
- **RV7 Minimum speed**  
This control sets the minimum armature voltage or motor speed.

# SAFTRONICS

---

---

## 3.0 RECEIVING & INSTALLATION

---

**3.1 Installation** The cabinet containing the DG2 PLUS must be installed in an area where the following conditions exist:

Ambient temperature does not exceed 40°C (104°F).

Ambient temperature is not less than 10°C (50°F).

Altitude above sea level is 2000 feet (600m) or less.

Ambient air is reasonably clean, dry and free of flammable or combustible vapors, steam, or corrosive gases, etc.

The cabinet must be installed away from any heat source, and a minimum of 1 foot (30.48 cm) is required around the air inlet and outlet, on ventilated units.

The DG2 PLUS has been designed for 50°C maximum inside the enclosure.

**3.2 Derating Data** When the unit is installed in poor environmental conditions, it must be derated as follows:

1.5% per C° above 40°C, or 0.75% per F° above 104°F.

15% per 1000 feet (300m) above 2000 feet (600m).

**3.3 Wiring** The DG2 PLUS is to be connected according to the NEC and any other applicable Electrical Codes in the customer's area. The chassis must be bonded to earth ground.

Section 6 pages 7, 8, and 9 show typical connections for speed controlled wound field motors. For permanent magnet motors, there will be no connections to F+ and F-.

See page 10 for typical torque control connections.

## 4.0 STARTUP

**4.1 Inspection** Ensure that the drive has been installed according to the previous guidelines. Also, ensure that the unit has been wired according to the schematics. Check that all connections are tight and that the motor can rotate freely.

- **AC input voltage selection**

Before power is applied, confirm that the voltage selection plug on the AA1128 card matches the supply voltage. DG2P-15 drives are factory set for 240 VAC input and are not reconfigurable. DG2P-10 drives may be configured for either 120 VAC or 240 VAC as follows. Locate 2 wire jumpers and a nylon plug housing in a plastic bag attached to the heatsink. Insert the wire jumpers into the housing according to one of the two drawings below depending on the AC input voltage. Insert the plug into connector JMP1. **If the input voltage is 240 VAC then jumper J4 must be removed.**

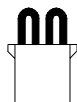

120 VAC

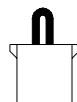

240 VAC

- **Field voltage selection**

Confirm that the field voltage is configured to match the field voltage of the motor according to its nameplate rating. Permanent magnet motors do not require field voltage configuration. Terminals 12 and 13 are jumpered as the factory standard default.

INPUT	TERMINALS 12-13	
	REMOVED	INSTALLED
120 VAC	50 VDC	100 VDC
240 VAC	100 VDC	200 VDC

**4.2 Prestart adjustments** All controls have been preset at the factory and should not require further adjustment.

*To prevent drive runaway, be very careful to establish tachogenerator polarity with the motor rotating in the desired direction. Then connect tach (+) to terminal 2 and tach (-) to terminal 1.*

The DG2 PLUS has been factory set for armature voltage feedback. To use tachometer feedback, remove the "ARM" link and install the "TACH" link (LK-3).

The "IR COMP" trimpot is not used with tachogenerator feedback, and must remain fully counterclockwise.

**4.3 Starting** Before applying power, refer to section 6.0 and ensure that all control and power wiring is correct, the power source, motor, and drive are matched, and that all links are properly set. Turn the speed pot to the zero reference position and ensure that the run circuit is disabled.

1. Measure and confirm that the AC supply voltage is correct according to the table on page 2. Confirm that the field voltage is correct according to the motor nameplate. Apply power and observe that LED1 "POWER" is illuminated.
2. Press the "START" pushbutton. Observe that LED2, "RUN", is illuminated and that the motor does not rotate. To set minimum speed, slowly increase RV7 until the motor reaches the desired speed. The external speed reference should be set at zero.
3. With the speed reference set at maximum, the motor should rotate at rated speed and/or voltage. If not, adjust RV6 for the correct setting.
4. If the acceleration and deceleration rates are not suitable, see section 2.4, p.3, for adjustment.

## 5.0 TROUBLESHOOTING

SYMPTOM	PROBABLE CAUSE
Motor does not run	<ul style="list-style-type: none"> <li>- No Run command.</li> <li>- Speed reference at 0 volts.</li> <li>- Blown fuses or no AC source.</li> </ul>
AC line fuse/fuses blown	<ul style="list-style-type: none"> <li>- SCR block shorted.</li> <li>- Field diodes shorted.</li> <li>- Grounded motor armature or field.</li> </ul>
Motor runs at slow speed with the speed pot set fully cw.	<ul style="list-style-type: none"> <li>- Max speed set too low.</li> <li>- Drive in current limit.</li> <li>- Bad speed pot.</li> </ul>
Motor unstable.	<ul style="list-style-type: none"> <li>- IR comp turned too high</li> <li>- Voltage stability set incorrectly.</li> <li>- Current stability set incorrectly.</li> <li>- Max speed set too high.</li> </ul>
Motor overspeeds with low speed reference	<ul style="list-style-type: none"> <li>- Max speed set too high.</li> <li>- Tach input reversed (if used).</li> <li>- No tach feedback if in tach mode.</li> </ul>
Motor drifts at zero speed	<ul style="list-style-type: none"> <li>- Requires anti-drift board p/n AA1060-B</li> </ul>

# SAFTRONICS

## 6.0 WIRING DIAGRAMS

### 6.1 DG2P-10 & DG2P-15

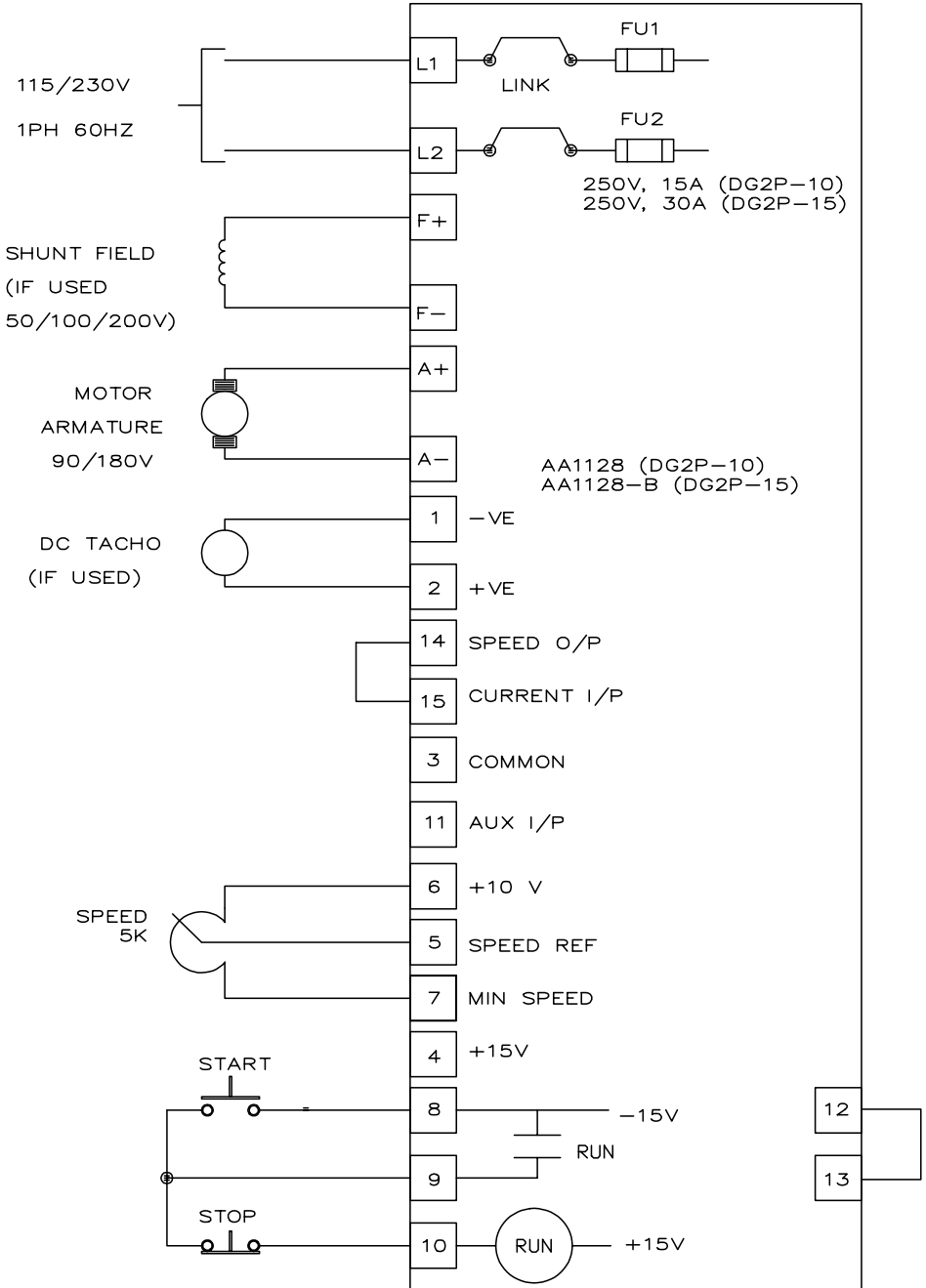

## 6.0 WIRING DIAGRAMS CONT'D

### 6.2 DG2P-25

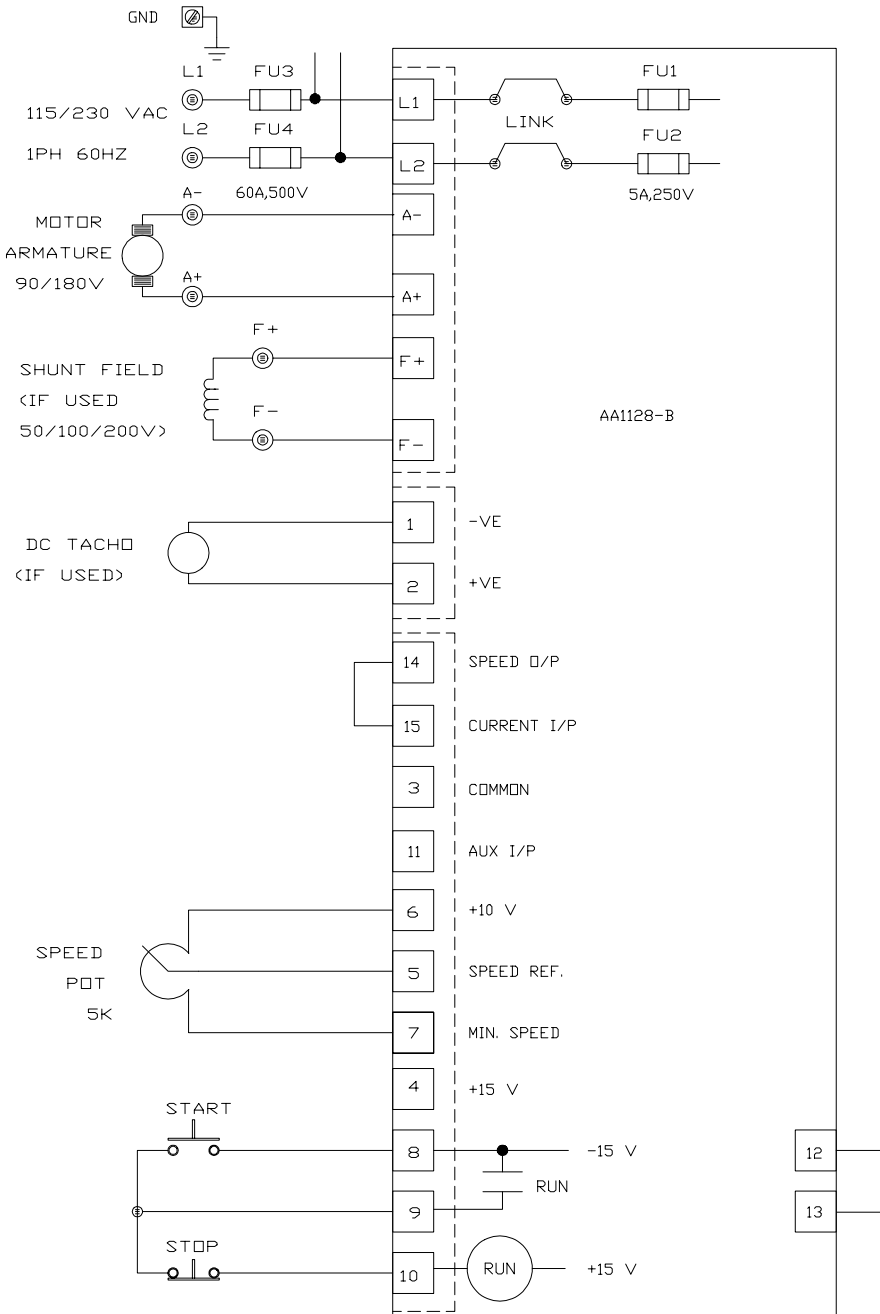

# SAFTRONICS

## 6.0 WIRING DIAGRAMS CONT'D

### 6.3 Typical Torque control connection

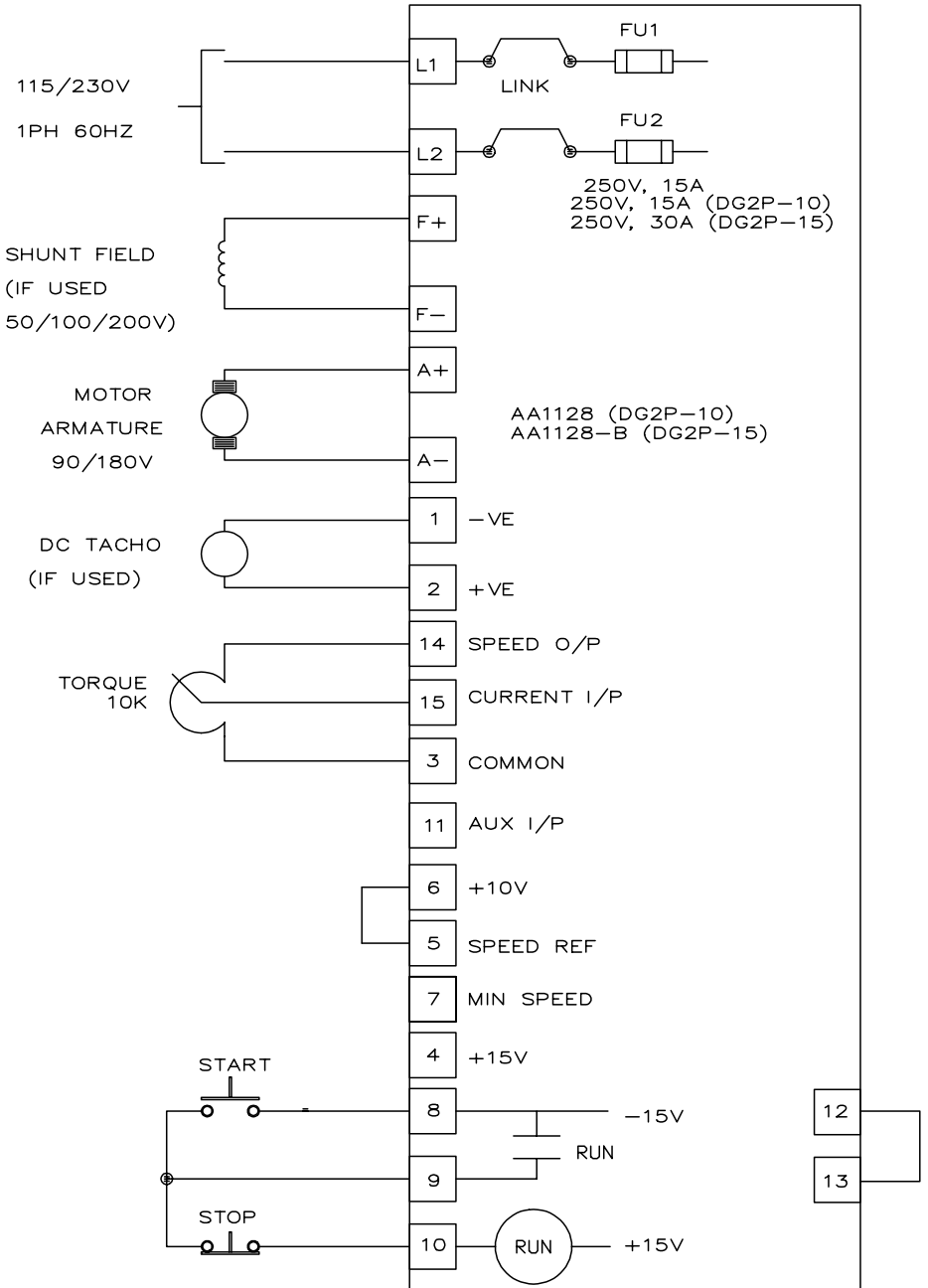

## 6.0 WIRING DIAGRAMS CONT'D

### 6.4 AA1128 schematic

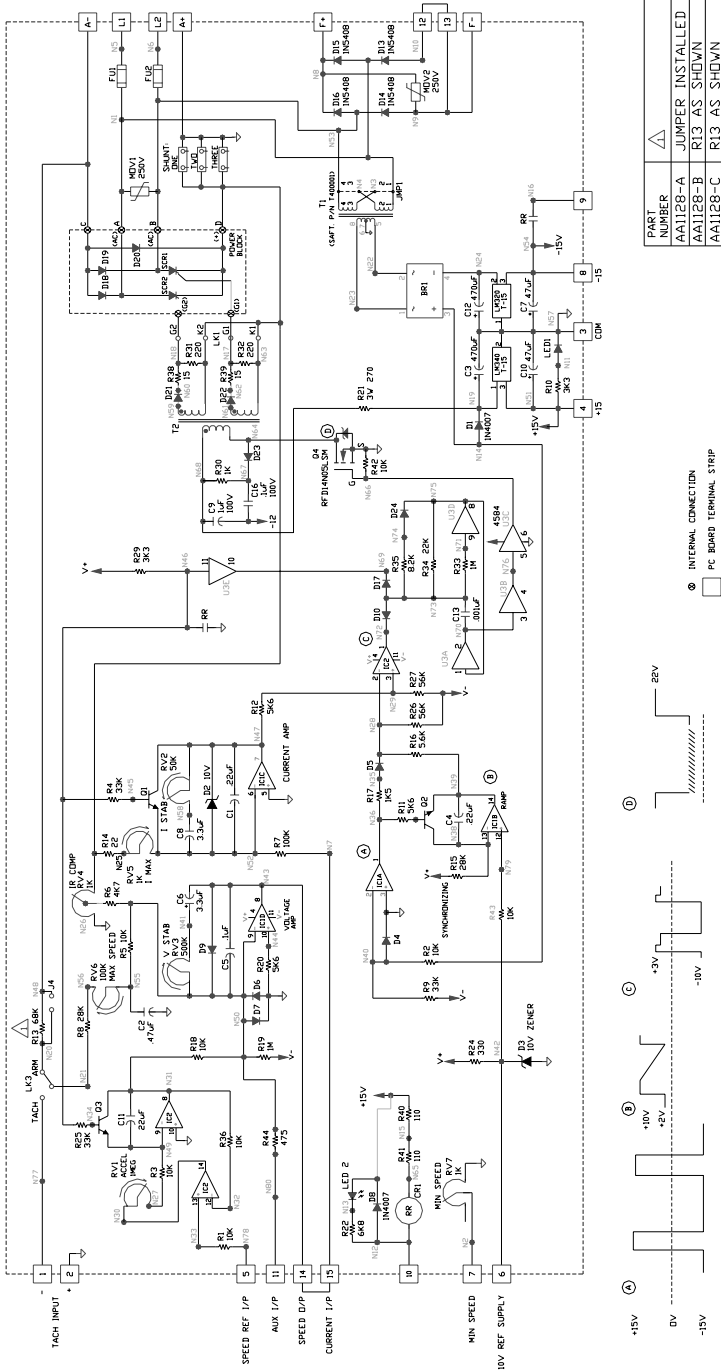

# SAFTRONICS

## 6.0 WIRING DIAGRAMS CONT'D

### 6.5 MOTOR CONNECTIONS

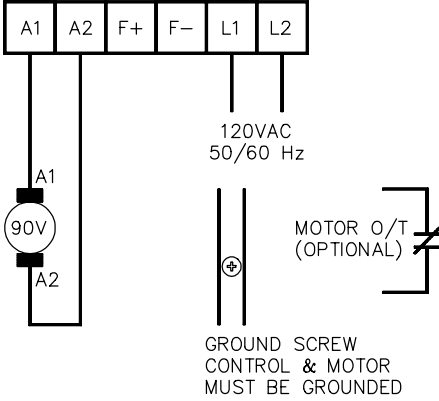

90V PERMANENT MAGNET

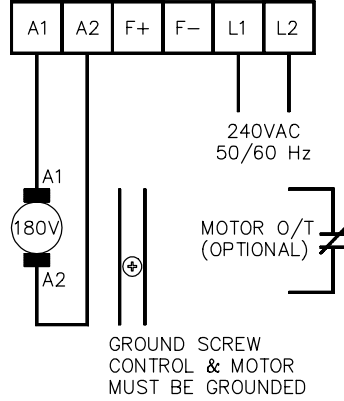

180V PERMANENT MAGNET

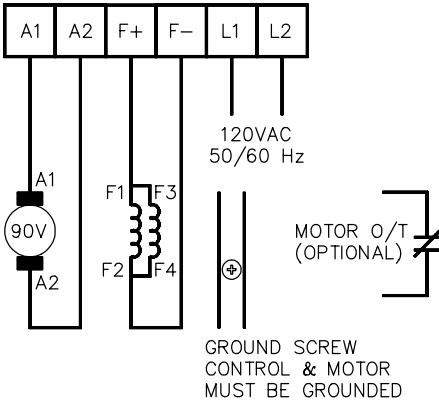

90V WOUND FIELD

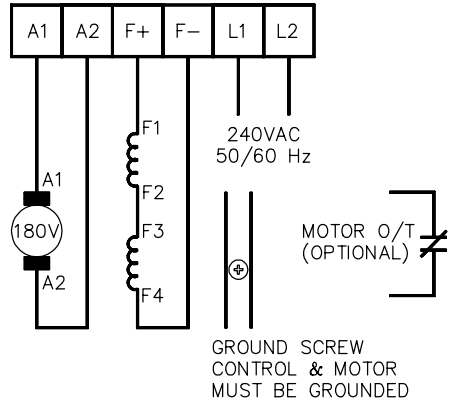

180V WOUND FIELD

## 7.0 DIMENSIONAL OUTLINES

### 7.1 DG2P-10 & DG2P-15

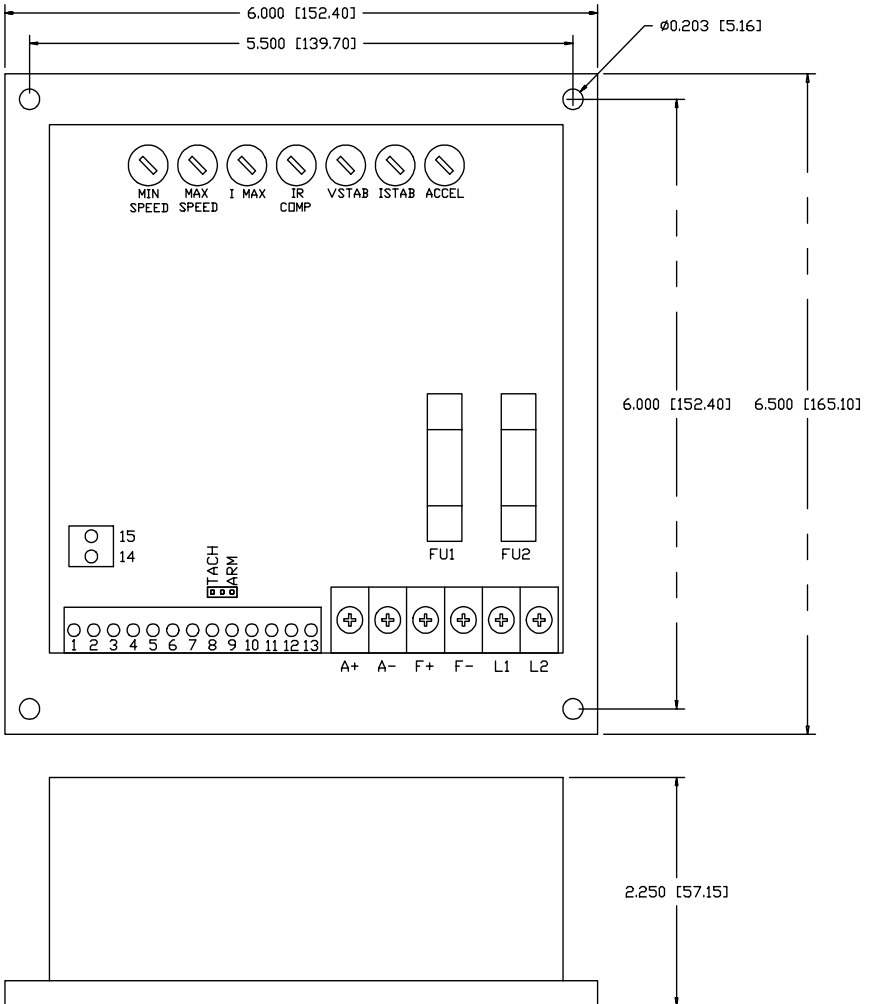

DIMENSIONS: INCHES [MILLIMETERS]

# SAFTRONICS

## 7.0 DIMENSIONAL OUTLINES CONT'D

### 7.2 DG2P-25

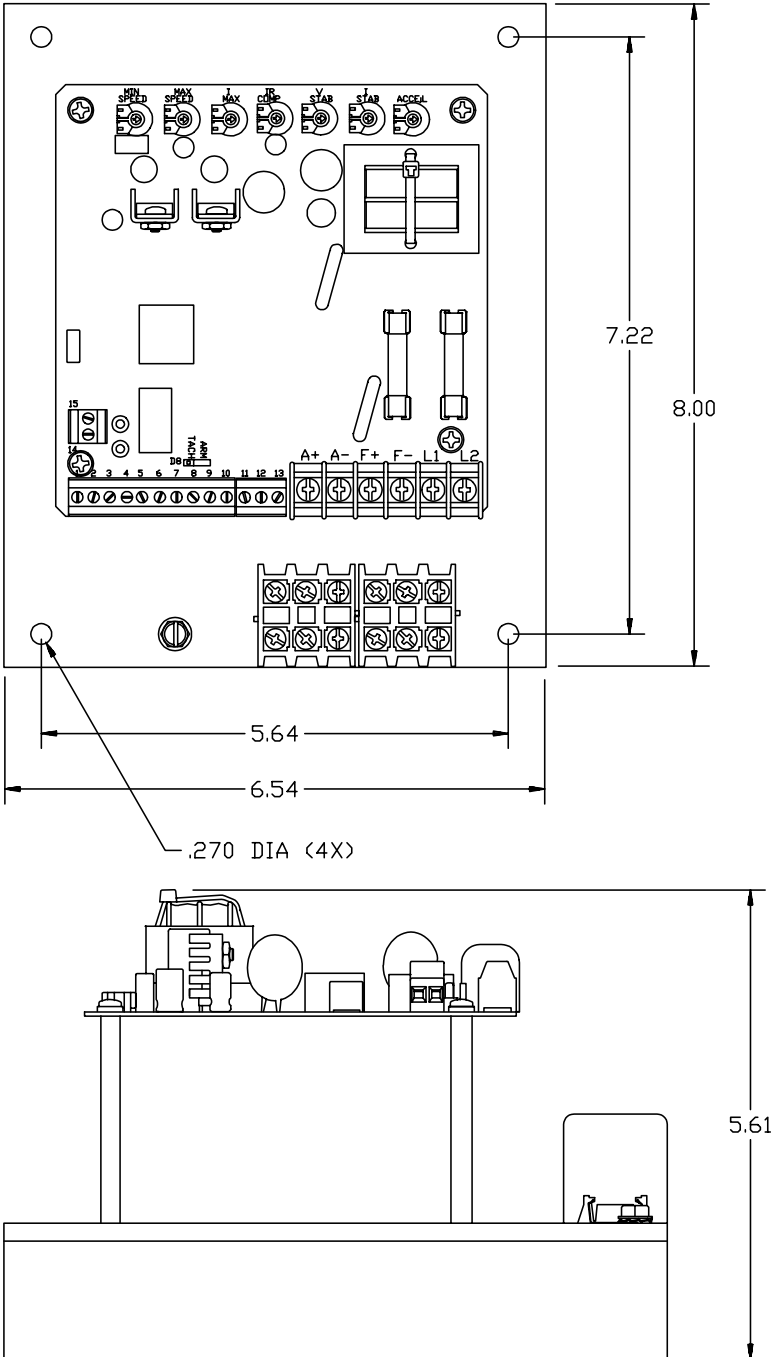

## 7.0 DIMENSIONAL OUTLINES CONT'D

### 7.3 DG2P-10, 15, 25 Enclosed

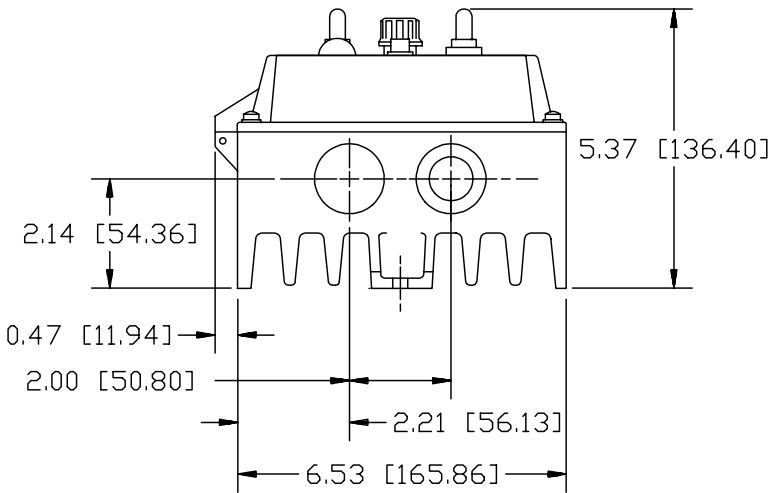
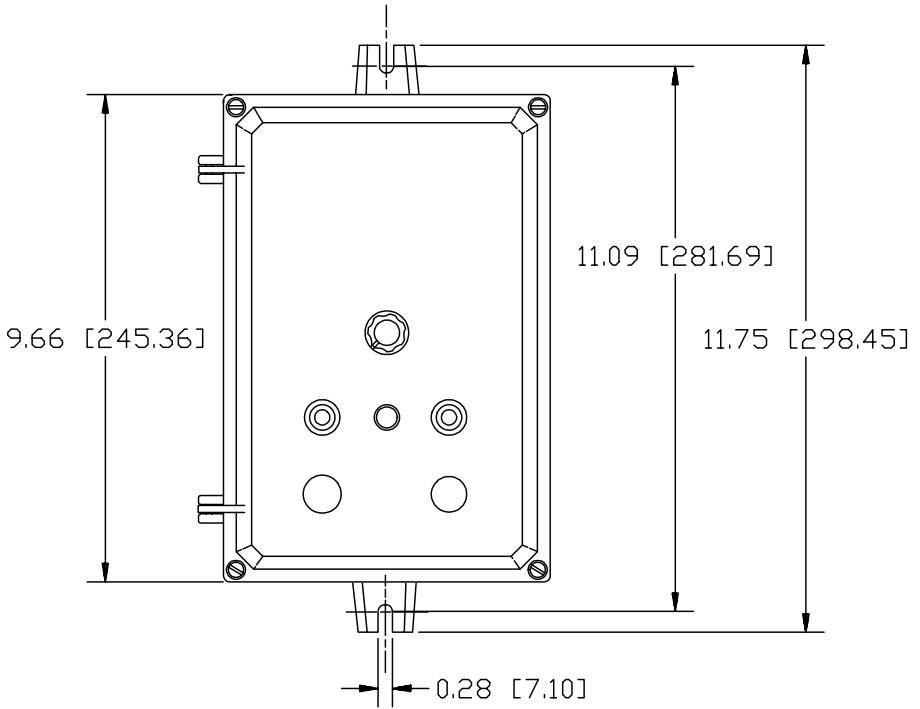

# SAFTRONICS

## 8.0 SPARE PARTS

SPARE PART	MODEL			
	DG2P-10	DG2P-15	DG2P-25	QTY
Controller Card AA1128	AA1128	AA1128-B	AA1128-B	1
SCR Bridge Assy	N500004	N500007	N500002	1
Fuses F1, F2	F601011-17 (20A)	F601012-36 (30A)	F601011-10 (5A)	2
Field Diodes	D3001-11	D3001-11	D3001-11	4
Power Fuses	—	—	F602003-05 (60A)	2

**Note:**

When replacing the controller card AA1128, ensure that

- 1) Incoming voltage selection plug is in the proper location.
- 2) Links match those of the previous card.

---

---

## 9.0 WARRANTY

---

Safronics warrants to buyer that products, and any services furnished hereunder will be free from defects in material, workmanship and title, and will be of the kind and quality specified in the quotation. The foregoing shall apply only to failures to meet said warranties (excluding any defects in title) which appear within one year from the date of shipment hereunder, provided, however, that if buyer, in the course of its regular and usual business, transfers title to or leases such products (including equipment incorporating such products) to a third party, such period shall run until one year from such transfer or lease or eighteen months from shipment by Safronics whichever occurs first. The warranties and remedies set forth herein are conditioned upon (a) proper storage, installation, use and maintenance, and conformance with any applicable recommendations of Safronics and, (b) buyer promptly notifying Safronics of any defects and, if required, promptly making the product available for correction.

If any products or services fails to meet the foregoing warranties (except title), Safronics shall thereupon correct any such failure either, at its option, (i) by repairing any defective or damaged part or parts of the products, or (ii) by making available FOB Safronics plant or other point of shipment, any necessary repaired or replacement parts. The preceding paragraph sets forth the exclusive remedies for claims (except as to title) based on defect in or failure of products or services, whether claim in contract or tort (including negligence) and however instituted. Upon expiration of the warranty period, all such liability shall terminate. The foregoing warranties are exclusive and in lieu of all other warranties, whether written, oral, implied or statutory. No implied statutory warranty of merchantability or fitness for particular purpose shall apply and Safronics will not be liable for any consequential damage arising from any product defect or failure to deliver on time. Safronics does not warrant any products or services of others which buyer has designated.