

**SECTION IX**

**DRAWINGS**

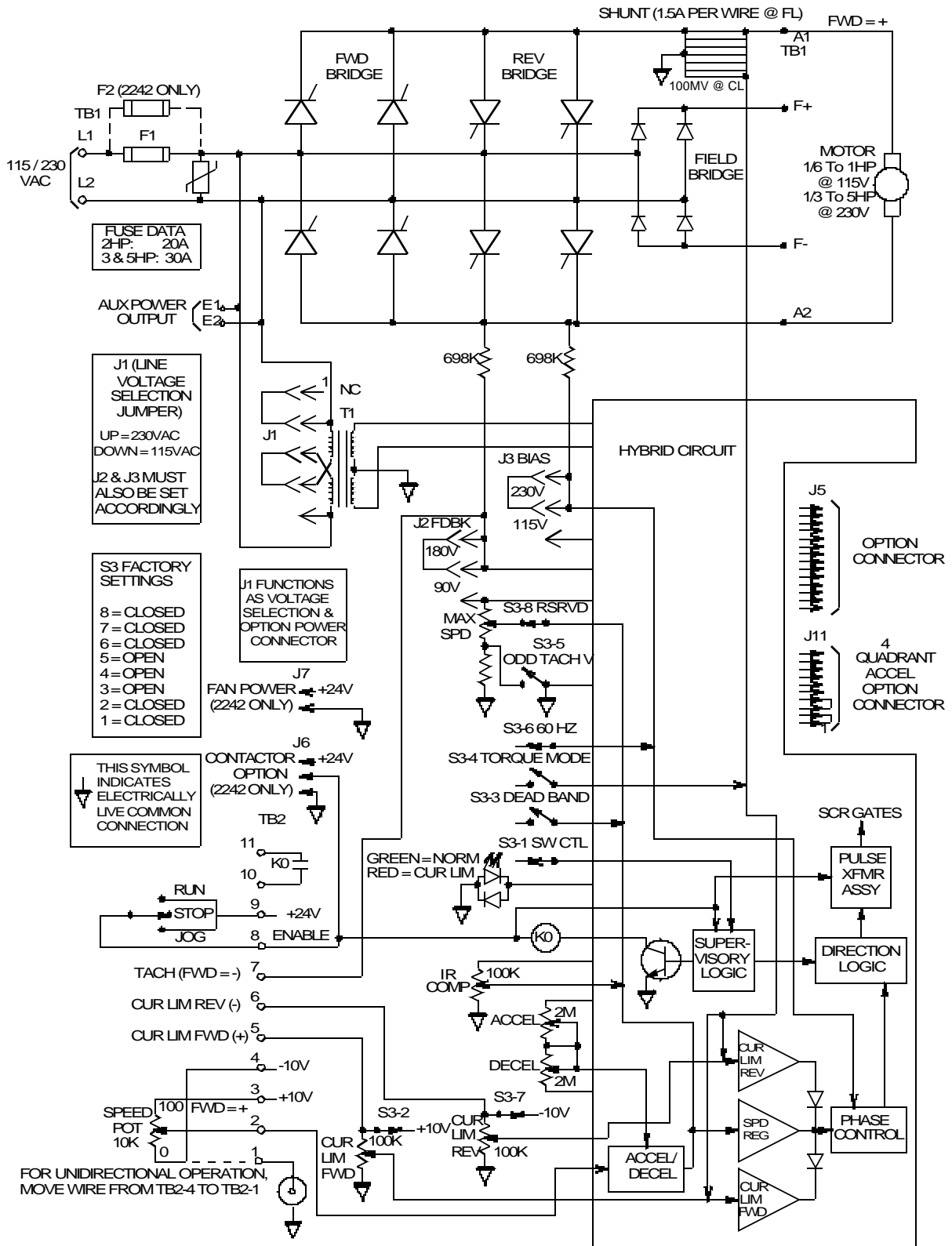

FIGURE 9-1. FUNCTIONAL SCHEMATIC, SERIES 2230/2240 CONTROLLERS

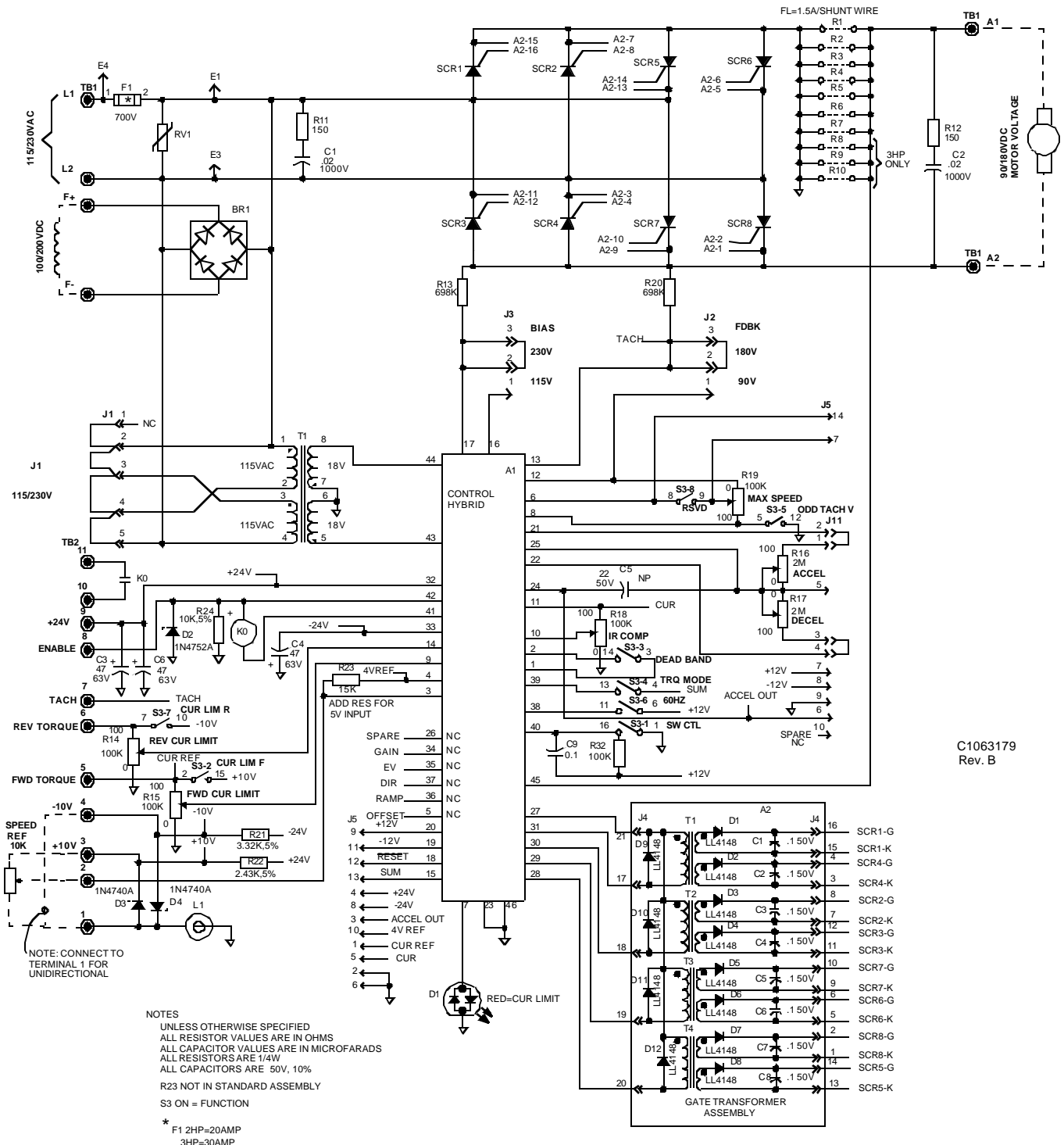
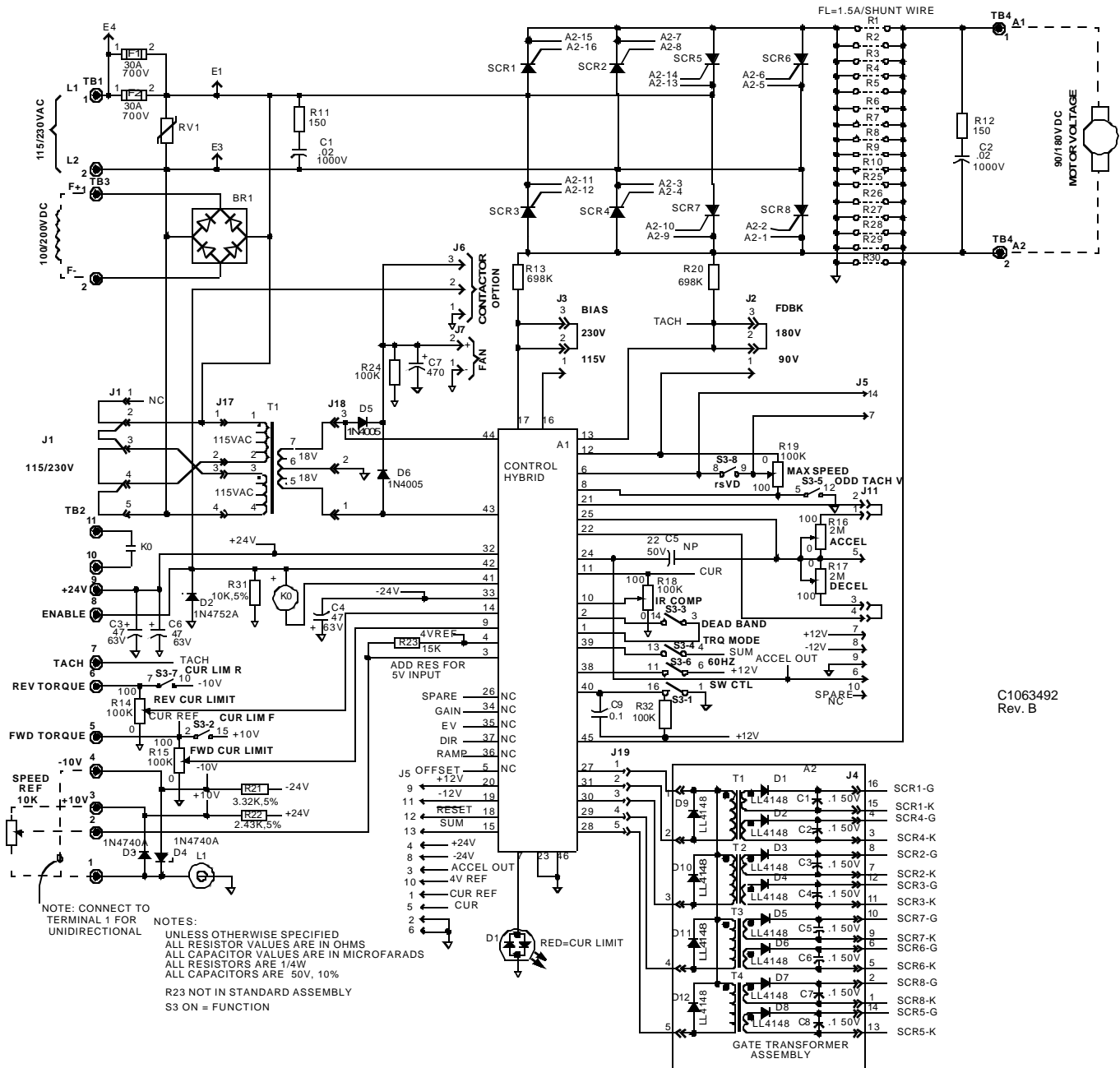
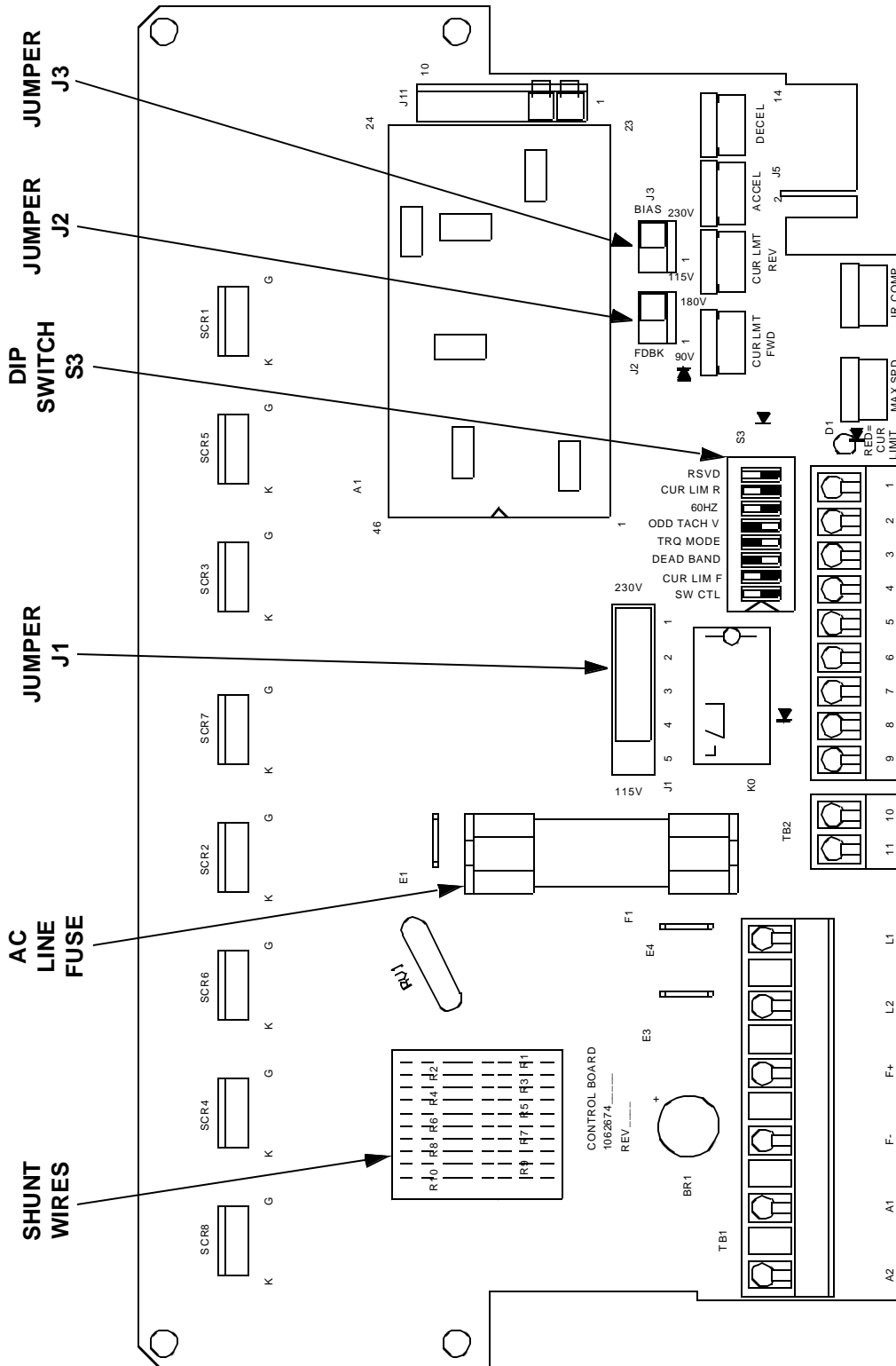

FIGURE 9-2. SCHEMATIC, MODEL 2231, 2232, 2235, AND 2236 CONTROLLERS



C1063492  
Rev. B

FIGURE 9-3. SCHEMATIC, MODEL 2242 CONTROLLER



NOTE: Not all components are shown.

FIGURE 9-4. CONTROL BOARD FOR MODEL 2231, 2232, 2235, AND 2236 CONTROLLERS

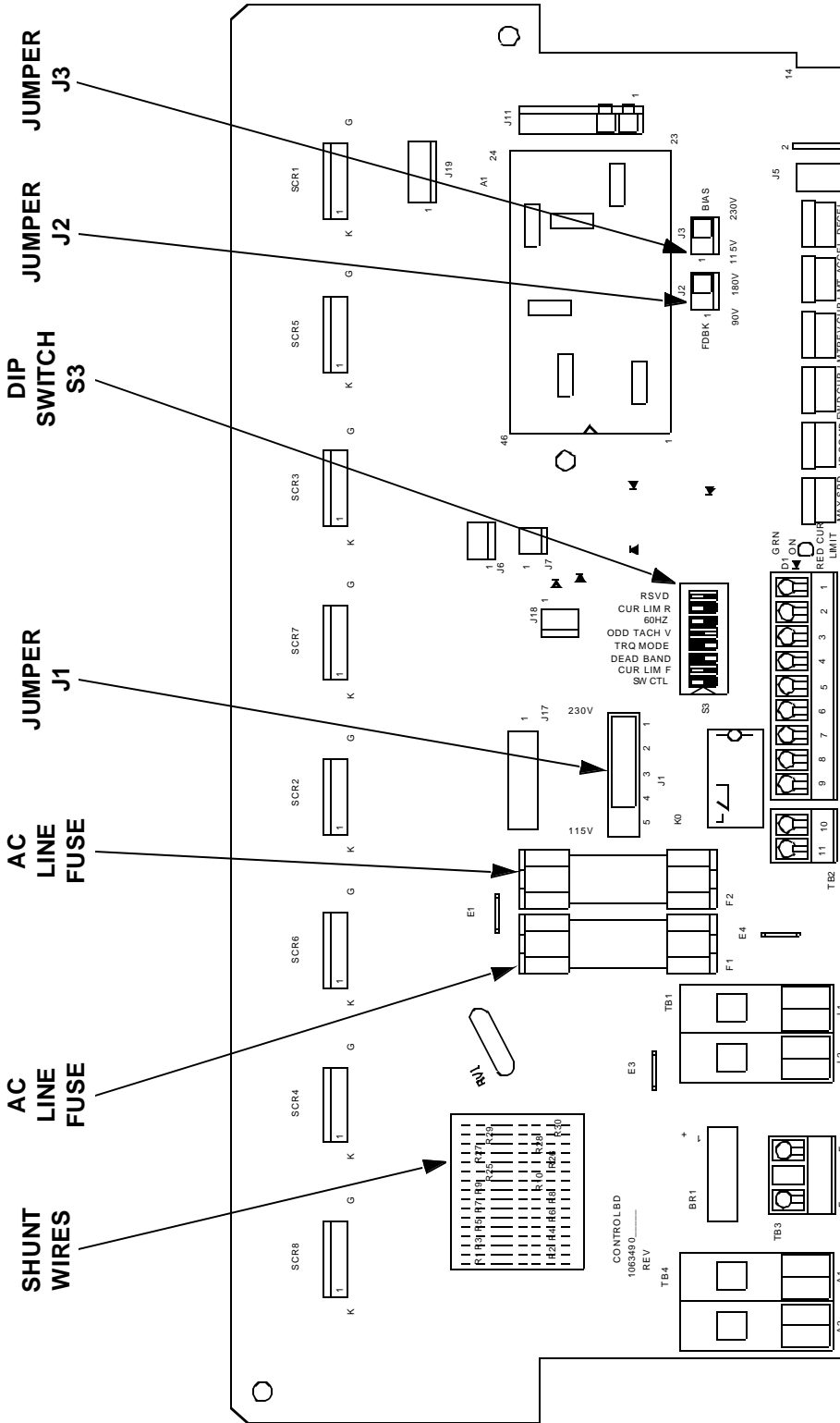

NOTE: Not all components are shown.

FIGURE 9-5. CONTROL BOARD FOR MODEL 2242 CONTROLLER