

5 through 1000 HP Adjustable Speed DC Motor Controllers

- HP Ratings 5-1000
- Voltage Ratings – 230, 380, 460
- NEMA C-Full Converter
- Isolated Regulator
- Overload Protection
- Commonality of Components
- Built-In Test Meter
- Voltage Transient Protection
- Extensive Options
- Field Economy
- Phase Loss Protection
- Phase Insensitive
- NEC & NEMA Compliance
- UL and cUL Listed†



FIGURE 1. Typical Series 3120S Module

TABLE 1. QUICK SELECT††

| HP | Voltage | Model Number |
|-------|---------|--------------|
| 5 | 230 | 3121S0051A |
| | 380 | 3121S00522A |
| | 460 | 3121S0053A |
| 7-1/2 | 230 | 3121S0071A |
| | 380 | 3121S00722A |
| | 460 | 3121S0073A |
| 10 | 230 | 3121S0101A |
| | 380 | 3121S01022A |
| | 460 | 3121S0103A |
| 15 | 230 | 3122S0151A |
| | 380 | 3121S01522A |
| | 460 | 3121S0153A |
| 20 | 230 | 3122S0201A |
| | 380 | 3122S02022A |
| | 460 | 3121S0203A |
| 25 | 230 | 3122S0251A |
| | 380 | 3122S02522A |
| | 460 | 3122S0253A |
| 30 | 230 | 3122S0301A |
| | 380 | 3122S03022A |
| | 460 | 3122S0303A |

| HP | Voltage | Model Number |
|-----|---------|--------------|
| 40 | 230 | 3123S0401A |
| | 380 | 3122S04022A |
| | 460 | 3122S0403A |
| 50 | 230 | 3123S0501A |
| | 380 | 3122S05022A |
| | 460 | 3122S0503A |
| 60 | 230 | 3123S0601A |
| | 380 | 3123S06022A |
| | 460 | 3122S0603A |
| 75 | 230 | 3123S0751A |
| | 380 | 3123S07522A |
| | 460 | 3123S0753A |
| 100 | 230 | 3124S1001A |
| | 380 | 3123S10022A |
| | 460 | 3123S1003A |
| 125 | 230 | 3124S1251A |
| | 380 | 3123S125221 |
| | 460 | 3123S1253A |
| 150 | 380 | 3124S15022A |
| | 460 | 3123S1503A |

| HP | Voltage | Model Number |
|------|---------|--------------|
| 200 | 380 | 3124S20022A |
| | 460 | 3124S2003A |
| 250 | 380 | 3125S250SSA |
| | 460 | 3124S2503A |
| 300 | 380 | 3125S30022A |
| | 460 | 3125S3003A |
| 400 | 380 | 3126S40022A |
| | 460 | 3125S4003A |
| 500 | 380 | 3126S50022A |
| | 460 | 3126S5003A |
| 600 | 380 | 3126S60022A |
| | 460 | 3126S6003A |
| 700 | 380 | 3127S70022A |
| | 460 | 3126S7003A |
| 800 | 380 | 3127S80022A |
| | 460 | 3127S8003A |
| 900 | 380 | 3127S90022A |
| | 460 | 3127S9003A |
| 1000 | 460 | 3127S10003A |

† Models through 125 HP-230V, 200 HP-460V

††See page B45 for current ratings.

DESIGN FEATURES AND FUNCTIONS

Model Type 3120M

1. **Power Conversion** — NEMA Type C full converter, using six silicon controlled rectifiers. Rated 1200 PIV. Power devices may be replaced with conventional tools without removing the 3120M module from the controller.
2. **Voltage Transient Protection** — Metal oxide suppressors across the AC line are combined with RC snubbers across the power bridge to limit potentially damaging high voltage spikes from the AC power source.
3. **Isolated Regulator** — Internal DC circuits are isolated from the AC power source for operator and equipment safety and for simplified application. The control reference input common may be grounded or connected without additional isolation to other drive units or grounded external signal sources. Isolation eliminates line voltage to ground potential being present on the speed control potentiometer.
4. **Feedback Isolation** —
 - (a) Current Feedback — Optical Isolation
 - (b) Voltage Feedback — High impedance circuit (4 megohms).
5. **Start-up Phase Insensitive** — Unit may be started-up with any phase rotation.
6. **Reference Power Supply** — Regulated + 10 VDC
7. **Armature Feedback** — Counter EMF voltage feedback and IR compensation are standard features. IR compensation is adjustable to suit individual motor characteristics.
8. **Phase-Loss Protection** — Interlocked with the controller run/stop logic.
9. **Overload Protection** — A protective circuit continuously monitors motor armature current and shuts down the Regulated Power Conversion Module should the armature current exceeds 120% for 80 seconds.
10. **Undervoltage Protection** — Interlocked to the controller run/stop logic.
11. **Field Supply** — Independent, 3-phase half-wave, DC excitation source, transient and fuse protected.
12. **Field Economy** — Automatically reduces the field voltage to 66% of rated whenever the armature contactor is opened. Reduces power consumption and motor heating during idle periods, extending the life of the motor.
13. **Test Meter** — A meter and multiple position switch monitors essential controller parameters:

| | |
|-----------------------------|--------------------------|
| a. 3 Phase AC line voltages | f. + 24 VDC Power Supply |
| b. DC armature load current | g. - 24 VDC Power Supply |
| c. + 12 VDC Power Supply | h. Field Voltage |
| d. - 12 VDC Power Supply | i. Reference Voltage |
| e. Error Voltage | j. Feedback Voltage |

Test meter is calibrated 0-150% with color coded scale segments for simplified troubleshooting.
14. **Static Current Limit Adjustment** — Permits simplified field adjustment of the current limit setting. This can be accomplished with the motor contactor open.

15. **Visual Indicators** — Included are individual LED's showing:

| | |
|----------------------------|-----------------------|
| a. Current limit operation | c. Phase-Loss |
| b. Overload Trip | d. Run Enable Command |

16. **Reconnectable Operation** — Units through Model 3124 may be programmed by a slide switch on the main control circuit board for either low (190-230V) or high (380-460V) voltage operation. Larger units (Model 3125 and above) are offered for 380-460V operation.
17. **50 Hz Operation** — Selected by a programming module on the main control circuit board.
18. **Auxiliary Interface Connections** — Terminals are provided for connection of the following inputs and outputs to external indicating and control devices to interface the 3120 with external system elements.
 - a. Control overload or phase-loss reset (input)
 - b. Current feedback signal 0 to - 5 VDC (output) equivalent to 0-150% armature current
 - c. + 24 VDC power supply for optional features (output) (1)
 - d. - 12 VDC regulated power supply @ 30 mA for optional features or external use (output) (1)
 - e. + 24 VDC run enable signal (output) (1)

Note: (1) 30 mA combined total for these outputs.
19. **Horsepower Calibration** — A multi-tap armature current shunt is provided for HP calibration.
20. **Modular Construction** — Rugged, lightweight, compact construction with deadback/front access to all components

Model Type 3120S

21. **Circuit Breaker** — A magnetic only, adjustable trip circuit breaker is provided as a means of disconnecting the AC input power to the controller and automatic instantaneous trip protection from a peak load.

This circuit breaker will qualify as a branch circuit protective device only when its interrupting capacity is coordinated with the distribution system (feeder) supplying the drive. Since the control circuit breaker is rated to protect the drive, it may not have sufficient capacity to protect the branch circuit from short circuit current. Optional current limiting fuses (Option 1018) or an additional circuit breaker may be required ahead of the control circuit breaker to protect both the drive and branch circuit. Table 5 shows the circuit breaker interrupting ratings.
22. **Enclosure** — NEMA Type 12 ventilated with hinged, latching door(s). See Table 6 for dimensions.
23. **Control Transformer** — 115 VAC secondary transformer isolates all magnetic control and logic from the AC power source for operator protection.
24. **Safety Features** — Isolated regulator • Low voltage operator control • High interrupting capacity AC circuit breaker • Armature contactor.
25. **Motor Contactor** — Magnetic DC contactor provides a positive disconnection of the motor armature from the controller power source. Action of the contactor is coordinated with the electronic power removal provided by a regulator sequencing circuit to ensure that only no power, "dry-switching" occurs for improved contactor longevity. Run logic interlocks are provided for use with a normally closed motor thermostat. Contactor is two-pole through the 3124 and single-pole above the 3124 with the two-pole optional.

TABLE 2. DESIGN SELECTION CHART

| HP | Input Voltage | Model Number | Line Amps | KVA | Motor Arm. Volts | Motor Arm. Amps | Max. Field Volts | Max. Field Amps | Rated Kilowatts (KW) | Std. Encl. & Approx. Wt. (lbs)† |
|-------|---------------|--------------|-----------|------|------------------|-----------------|------------------|-----------------|----------------------|-------------------------------------|
| 5 | 230 | 3121S0051A | 18 | 8 | 240V | 18 | 150V | 5 | 3.7 | W8, 160 |
| | 380 | 3121S00522A | 11 | 8 | 440V | 10 | 240V | | | |
| | 460 | 3121S0053A | 10 | 8 | 500V | 9 | 300V | | | |
| 7-1/2 | 230 | 3121S0071A | 26 | 11 | 240V | 28 | 150V | 5 | 5.6 | W8, 160 |
| | 380 | 3121S00722A | 16 | 11 | 440V | 16 | 240V | | | |
| | 460 | 3121S0073A | 14 | 11 | 500V | 14 | 300V | | | |
| 10 | 230 | 3122S0101A | 32 | 14 | 240V | 36 | 150V | 5 | 7.5 | W8, 160 |
| | 380 | 3121S01022A | 20 | 14 | 440V | 21 | 240V | | | |
| | 460 | 3121S0103A | 17 | 14 | 500V | 18 | 300V | | | |
| 15 | 230 | 3122S0151A | 48 | 19 | 240V | 55 | 150V | 5 | 11.2 | W8, 160 |
| | 380 | 3121S01522A | 27 | 19 | 440V | 29 | 240V | | | |
| | 460 | 3121S0153A | 23 | 19 | 500V | 25 | 300V | | | |
| 20 | 230 | 3122S0201A | 60 | 25 | 240V | 70 | 150V | 5 | 14.9 | W8, 160 |
| | 380 | 3122S02022A | 35 | 25 | 440V | 40 | 240V | | | |
| | 460 | 3121S0203A | 31 | 25 | 500V | 35 | 300V | | | |
| 25 | 230 | 3122S0251A | 78 | 31 | 240V | 90 | 150V | 5 | 18.7 | W8, 160 |
| | 380 | 3122S02522A | 43 | 31 | 440V | 49 | 240V | | | |
| | 460 | 3122S0253A | 38 | 31 | 500V | 43 | 300V | | | |
| 30 | 230 | 3122S0301A | 90 | 36 | 240V | 105 | 150V | 5 | 22.4 | W8, 160 |
| | 380 | 3122S03022A | 51 | 36 | 440V | 58 | 240V | | | |
| | 460 | 3122S0303A | 44 | 36 | 500V | 51 | 300V | | | |
| 40 | 230 | 3123S0401A | 119 | 47 | 240V | 140 | 150V | 5 | 29.8 | U200, 370 W8, 160 W8, 160 |
| | 380 | 3122S04022A | 65 | 47 | 440V | 75 | 240V | | | |
| | 460 | 3122S0403A | 57 | 47 | 500V | 66 | 300V | | | |
| 50 | 230 | 3123S0501A | 148 | 59 | 240V | 175 | 150V | 5 | 37.3 | U200, 370 W8, 160 W8, 160 |
| | 380 | 3122S05022A | 80 | 59 | 440V | 94 | 240V | | | |
| | 460 | 3122S0503A | 71 | 59 | 500V | 83 | 300V | | | |
| 60 | 230 | 3123S0601A | 177 | 70 | 240V | 210 | 150V | 5 | 44.8 | U200, 370 U200, 370 W8, 160 |
| | 380 | 3123S06022A | 95 | 70 | 440V | 112 | 240V | | | |
| | 460 | 3122S0603A | 83 | 70 | 500V | 98 | 300V | | | |
| 75 | 230 | 3123S0751A | 216 | 86 | 240V | 258 | 150V | 5 | 56.0 | U200, 370 |
| | 380 | 3123S07522A | 118 | 86 | 440V | 140 | 240V | | | |
| | 460 | 3123S0753A | 103 | 86 | 500V | 123 | 300V | | | |
| 100 | 230 | 3124S1001A | 285 | 114 | 240V | 342 | 150V | 10 5 5 | 74.6 | U200, 420 U200, 370 U200, 370 |
| | 380 | 3123S10022A | 155 | 114 | 440V | 185 | 240V | | | |
| | 460 | 3123S1003A | 136 | 114 | 500V | 163 | 300V | | | |
| 125 | 230 | 3124S1251A | 336 | 137 | 240V | 426 | 150V | 10 5 5 | 93.3 | U200, 420 U200, 370 U200, 370 |
| | 380 | 3123S125221 | 194 | 137 | 440V | 233 | 240V | | | |
| | 460 | 3123S1253A | 173 | 137 | 500V | 205 | 300V | | | |
| 150 | 380 | 3124S15022A | 231 | 163 | 440V | 278 | 240V | 10 5 | 111.9 | U200, 420 U200, 370 |
| | 460 | 3123S1503A | 205 | 163 | 500V | 245 | 300V | | | |
| 200 | 380 | 3124S20022A | 306 | 219 | 440V | 370 | 240V | 10 | 149.2 | U200, 420 |
| | 460 | 3124S2003A | 275 | 219 | 500V | 325 | 300v | | | |
| 250 | 380 | 3125S250SSA | 376 | 267 | 440V | 455 | 240V | 10 | 186.5 | F3, 1500 U200, 420 |
| | 460 | 3124S2503A | 336 | 267 | 500V | 400 | 300V | | | |
| 300 | 380 | 3125S30022A | 451 | 314 | 440V | 546 | 240V | 10 | 223.8 | F3, 1500 |
| | 460 | 3125S3003A | 402 | 314 | 500V | 480 | 300V | | | |
| 400 | 380 | 3126S40022A | 595 | 421 | 440V | 722 | 240V | 10 | 298.4 | F3, 1793 F3, 1500 |
| | 460 | 3125S4003A | 529 | 421 | 500V | 635 | 300V | | | |
| 500 | 380 | 3126S50022A | 739 | 522 | 440V | 898 | 240V | 10 | 373 | F3, 1793 |
| | 460 | 3126S5003A | 656 | 522 | 500V | 790 | 300V | | | |
| 600 | 380 | 3126S60022A | 889 | 633 | 440V | 1091 | 240V | 10 | 447.6 | F3, 1793 |
| | 460 | 3126S6003A | 795 | 633 | 500V | 960 | 300V | | | |
| 700 | 380 | 3127S70022A | 1047 | 738 | 440V | 1120 | 240V | 10 | 522.2 | F3, 1893 F3, 1793 |
| | 460 | 3126S7003A | 927 | 738 | 500V | 1120 | 300V | | | |
| 800 | 380 | 3127S80022A | 1196 | 842 | 440V | 1280 | 240V | 10 | 596.8 | F3, 1893 |
| | 460 | 3127S8003A | 1058 | 842 | 500V | 1280 | 300V | | | |
| 900 | 380 | 3127S90022A | 1345 | 947 | 440V | 1637 | 240V | 10 | 671.4 | F3, 1893 |
| | 460 | 3127S9003A | 1190 | 947 | 500V | 1440 | 300V | | | |
| 1000 | 460 | 3127S10003A | 1320 | 1050 | 500V | 1600 | 300V | 10 | 746 | F3, 1893 |

†Refer to Table 6 for dimensions.

THREE-PHASE DC SERIES

RATINGS AND CHARACTERISTICS

OPERATING CONDITIONS

1. **Line Voltage Variation** ±10% of rated
2. **Line Frequency Variation** ±2 Hz
3. **Ambient Temperature (1)** 0 to 40°C (32° to 104°F)
4. **Altitude (Standard)** 3300 feet (1000m) maximum

NOTE: (1) Series 3120 modules are designed for panel mounting where the internal temperature of the enclosure does not exceed 55°C (131°F).

PERFORMANCE CHARACTERISTICS

1. **Controlled speed range** – Zero to motor base speed. Speed range with respect to the specified regulation is as shown in Table 4. See Catalog Section E for constant torque continuous duty application limitations of DC motors.
2. **Speed Regulation** – Regulation percentages shown in Table 4 are of motor base speed under steady-state conditions.
3. **Efficiency** (maximum speed and rated load)
 - (a) Controller SCR regulator 99%
 - (b) Complete drive with motor (typical) 87%
4. **Displacement Power Factor** (maximum speed and rated load) 88%

ADJUSTMENTS

1. **Acceleration/Deceleration** 1-30 seconds
Linear, independently adjustable
2. **Current Limit** 50-150% full-load torque
3. **Maximum Current** 150% full-load torque (factory set)
4. **Minimum Speed** 0-25% of motor base speed
5. **Maximum Speed** 70-100% of motor base speed
6. **IR (load) Compensation** 0-100% of rated load

RATINGS

1. **Horsepower Range** 5-1000 HP
2. **Power Source** See Table 3.
3. **Output Voltages** See Table 3.
4. **Reference Voltage** See Table 3.
5. **Service Factor** 1.0
6. **Duty** Continuous
7. **Overload Capacity** (armature circuit current) 150% for 1 minute
8. **AC Line Circuit Breaker, Interrupting Ratings** See Table 5.
9. **Run-Speed Potentiometer** 5K, 1/2 W

TABLE 3. SERIES 3120 OPERATING VOLTAGES

| Power Source (3-Phase) | | Output VDC | | Magnetic Control Voltage | Control Reference Voltage |
|------------------------|----------|------------|----------|--------------------------|---------------------------|
| Volts | Hz. | Armature | Field(1) | | |
| 230 | 50 or 60 | 0-240 | 150 | 115 VAC | 10 VDC |
| 460 | 50 or 60 | 0-500 | 300 | | |
| 220 | 50 | 0-260 | 150 | | |
| 380 | 50 | 0-440 | 250 | | |
| 415 | 50 | 0-460 | 270 | | |

Note (1) For field voltages other than those shown, see Option Number 1079, Constant Current Field Power Supply.

TABLE 4. SPEED REGULATION CHARACTERISTICS

| Regulation Method | Variable | | | | |
|--|-----------------|-------------------------|---------------------|-------------------|-------------|
| | Load Change 95% | Field Line Voltage +10% | Heating Cold-Normal | Temperature +10°C | Speed Range |
| Standard Voltage Feedback with IR Compensation | 2% | ±1% | 5-12% | +2% | 50:1 |
| Optional Speed Feedback 1061C w/5PY DC Tach | 0.5% | ±1% | 0.2% | ±2% | 200:1 |
| Optional Speed Feedback 1061C w/BC42 DC Tach and Precision Reference Option 1059 | 0.2% | ±0.1% | 0.2% | ±0.1% (1) | 500:1 |

NOTE: (1) With BC 46 Tach ±0.05%, all other data the same as BC-42.

TABLE 5. CIRCUIT BREAKER FAULT INTERRUPTING CAPACITY

| Maximum HP | | | Circuit Breaker Data | | | | |
|------------|------|------|----------------------|-----------------|-------------------|---|---------|
| | | | Type | Trip Range Amps | Cont. Rating Amps | Interrupting Rating-Symmetrical Amperes | |
| 230V | 380V | 460V | | | | 230V | 460V |
| 10 | 15 | 20 | HMCP | 115-170 | 70 | 100,000 | 65,000 |
| 30 | 50 | 60 | HMCP | 210-560 | 100 | 100,000 | 65,000 |
| 75 | 125 | 150 | HMCP | 350-700 | 250 | 100,000 | 65,000 |
| 125 | 200 | 250 | HMCP | 350-700 | 400 | 100,000 | 65,000 |
| — | 250 | 300 | MAL | 2500-5000 | 500 | 30,000 | 30,000 |
| — | 310 | 400 | MAL | 2500-5000 | 600 | 30,000 | 30,000 |
| — | 400 | 500 | MAL | 5000-10000 | 800 | 30,000 | 30,000 |
| — | 500 | 600 | MAL | 5000-10000 | 1000 | 30,000 | 30,000 |
| — | 600 | 700 | NAL | 5000-10000 | 1200 | 50,000 | 50,000 |
| — | 700 | 800 | NAL | 5000-10000 | 1200 | 50,000 | 50,000 |
| — | 800 | 900 | PB | 2500-7000 | 1400 | 200,000 | 200,000 |
| — | 900 | 1000 | PB | 3000-8000 | 1600 | 200,000 | 200,000 |

DIMENSIONS

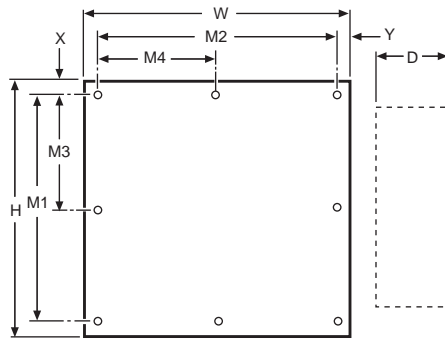

| Model Number | Maximum Horsepower | | | Dimensions, Inches (mm) | | | | | | | | |
|--------------|--------------------|------|------|-------------------------|----------------|---------------|-----------------|-----------------|-----------------|----------------|-------------|-------------|
| | 230V | 380V | 460V | Panel | | | Mounting | | | | | |
| | H | W | D | M1 | M2 | M3 | M4 | X | Y | | | |
| 3121S | 10 | 15 | 20 | 27.0 (686) | 29.0 (737) | 8.6 (218) | 26.0 (660) | 28.0 (711) | — | — | 0.5 (13) | 0.5 (13) |
| 3122S | 30 | 50 | 60 | 45.0 (1143) | 35.0 (889) | 10.4 (264) | 44.0 (1118) | 34.0 (864) | 22.0 (559) | — | 0.5 (13) | 0.5 (13) |
| 3123S | 75 | 125 | 150 | 45.0 (1143) | 35.0 (889) | 11.6 (295) | 44.0 (1118) | 34.0 (864) | 22.0 (559) | — | 0.5 (13) | 0.5 (13) |
| 3124S | 125 | 200 | 250 | 45.0 (1143) | 35.0 (889) | 11.6 (295) | 44.0 (1118) | 34.0 (864) | 22.0 (559) | — | 0.5 (13) | 0.5 (13) |
| 3125S | — | 300 | 400 | 86.0 (2184) | 70.0 (1778) | 18.0 (457) | 84.25 (2140) | 68.25 (1734) | 42.13 (1070) | 34.13 (867) | 0.9 (23) | 0.9 (23) |
| 3126S | — | 600 | 700 | | | | | | | | | |
| 3127S | — | 900 | 1000 | | | | | | | | | |

FIGURE 2. 3120S Unenclosed (Panel Mounted) Configuration

TABLE 6. ENCLOSURE DIMENSIONS

| Enclosure Model | Dimensions, Inches (mm) (1) | | | | | | | |
|--------------------|-----------------------------|--------------|----------------|---------------|----------------|---------------|---------------|---------------|
| | Enclosure | | | | Mounting | | | |
| | H | H2 (2) | W | D | M1 | M2 | M3 | M4 |
| W8 (Figure 3) | 30.3 (770) | — | 30.3 (770) | 12.0 (305) | 28.5 (724) | 25.0 (635) | — | — |
| U200 (Figure 4) | 55.0 (1397) | 62 (1575) | 36.5 (927) | 15.3 (389) | 51.0 (1295) | 32.0 (813) | 33.5 (851) | 11.0 (279) |
| F3 (Figure 5) | 90.0 (2286) | — | 72.0 (1824) | 25.5 (648) | — | — | — | — |

Notes: (1) Dimensions are for reference only.
(2) With Option 1039 (Penthouse).

OPERATOR CONTROLS

Table 7 lists companion operator control stations for use with Series 3120 controllers. All operator stations listed are NEMA 1, nonventilated; essential dimensions are shown in Figure 6. All control stations are suitable for use when Dynamic Braking, Option 1039, is combined with the listed options.

TABLE 7. OPERATOR CONTROL STATIONS

| Catalog Number | Use With Controller Options | Control Elements | | |
|----------------|-----------------------------|------------------|---------------|--------------------------|
| | | Pushbuttons | Toggle Switch | Potentiometer |
| SCS 161 | Basic | Run, Stop | — | 1-Turn Run |
| SCS 163 | 1022 | Run, Stop | Run-Jog | 1-Turn Run 1-Turn Jog |
| SCS 165 | 1019 or 1023 or 1024 | Run, Stop, Jog | — | 1-Turn Run |
| SCS 166 | 1004 | Fwd, Rev, Stop | — | 1-Turn Run |

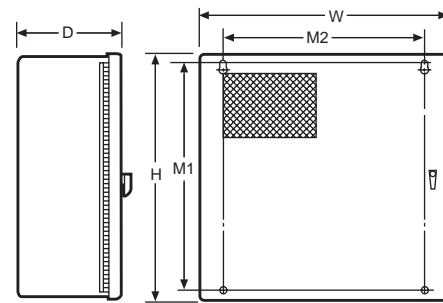
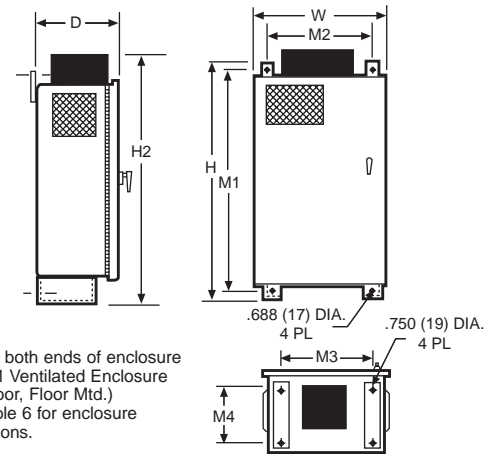

FIGURE 3. NEMA 1 Ventilated Enclosure, W8



NOTES:
(1) Vent on both ends of enclosure
(2) NEMA 1 Ventilated Enclosure (Two Door, Floor Mtd.)
(3) See Table 6 for enclosure dimensions.

FIGURE 4. NEMA 1 Ventilated Enclosure, U200

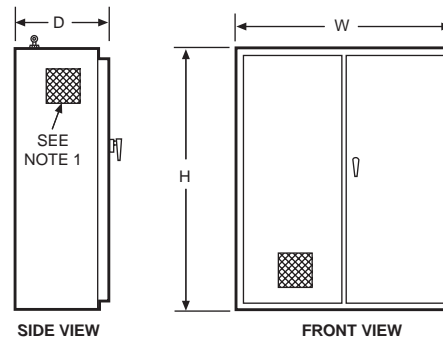

FIGURE 5. NEMA 1 Ventilated Enclosure, F3

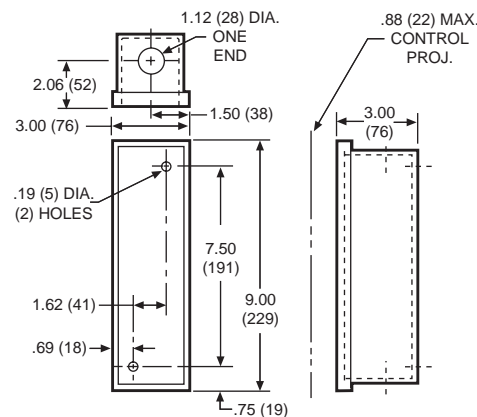

FIGURE 6. Operator Control Stations

POWER CONVERSION MODULES



FIGURE 7. Typical 3120M Regulator Power Conversion Module

3120M – Basic six-pulse power conversion and regulator module. Offered as a chassis-mount unit for the OEM or panel builder who may want to build his own custom system by adding protective devices, armature contactor and magnetic control logic. The 3120M, shown in Figure 7, forms the nucleus of all other 3120 models. See Figure 8 for 3120M dimensions. Seven modules cover the design range of 5-100 HP and uses design features and functions 1 through 23 only.

TABLE 8. HORSEPOWER RANGE

| Model Number | Rated Armature Amps. (1) | Max. Horsepower (2) | | |
|--------------|--------------------------|---------------------|------|------|
| | | 230V | 380V | 460V |
| 3121 M | 36 | 15 | 15 | 20 |
| 3122 M | 105 | 30 | 50 | 60 |
| 3123 M | 258 | 75 | 125 | 150 |
| 3124 M | 426 | 125 | 200 | 250 |
| 3125 M | 635 | NA | 300 | 400 |
| 3126 M | 1120 | NA | 600 | 700 |
| 3127 M | 1600 | NA | 900 | 1000 |

NOTES:

- (1) Armature current ratings listed are the maximum continuous rating at 100% rated load. A 150% overload capacity permits current limit operation up to one minute.
- (2) Horsepower ratings are typical. If motor data plate armature amps exceed those listed a higher rated 3120 must be selected.

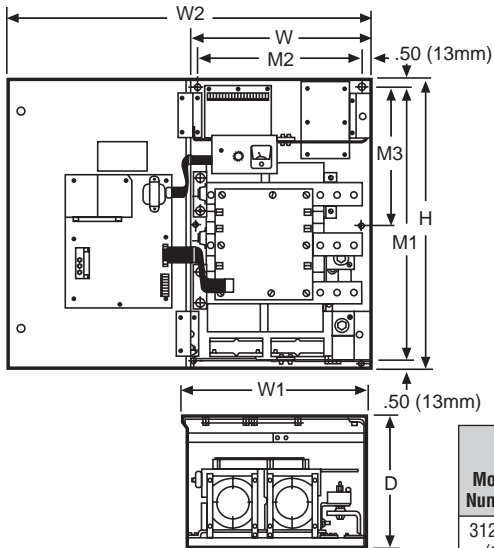

FIGURE A

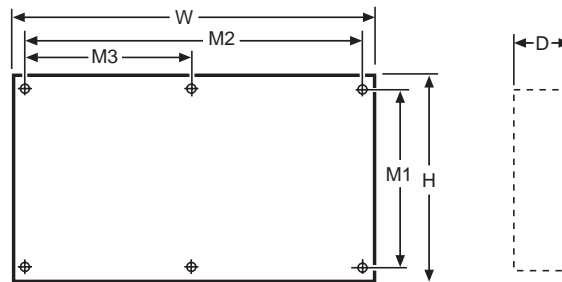

FIGURE B

| Model Number | Maximum Horsepower | | | Weight lbs. (kgs) | Dimensions, Inches (mm) (3) | | | | | | | | | Fig. | | | | | | | |
|--------------|--------------------|------|------|-------------------|-----------------------------------|-------|-------|-------|----------|-------|-------|-------|---------------|------|-------|--------|-------|-------|--------|-------|-----------------|
| | 230V | 380V | 460V | | Regulated Power Conversion Module | | | | Mounting | | | | | | | | | | | | |
| | | | | | H | W | D | W1 | W2 | M1 | M2 | M3 | Holes | | | | | | | | |
| 3121M (1) | 15 | 15 | 20 | 24 (10.8) | 19.0 | 12.0 | 8.5 | 12.3 | 24.5 | 18.0 | 11.0 | — | 4x | A | | | | | | | |
| 3122M (1) | 30 | 50 | 60 | 26 (11.7) | (483) | (305) | (216) | (312) | (622) | (457) | (279) | — | .281 (7) Dia. | A | | | | | | | |
| 3123M (1) | 75 | 125 | 150 | 49 (22.1) | 19.5 | 14.5 | 10.3 | 14.8 | 29.6 | 18.5 | 13.5 | — | 4x | A | | | | | | | |
| 3124M (1) | 125 | 200 | 250 | 66 (29.7) | 26.0 | 16.0 | 11.5 | 16.3 | 32.6 | 25.0 | 15.0 | 12.5 | 6x | A | | | | | | | |
| 3125M (2) | — | 300 | 400 | 225 (102.3) | 30.0 | 48.0 | 11.2 | — | — | 28.25 | 46.25 | 23.13 | 6x | B | | | | | | | |
| 3126M (2) | — | 600 | 700 | | | | | | | | | | | | (762) | (1219) | (285) | (718) | (1175) | (588) | .41 (10.4) Dia. |
| 3127M (2) | — | 900 | 1000 | | | | | | | | | | | | | | | | | | |

NOTE: (3) Dimensions are for reference only.

FIGURE 8. 3120M Regulator Power Conversion Module Dimensions

OPTIONS

The versatility of the Series 3120 controllers is further extended by selecting one or more of the following options. Table 9 lists the allowable combinations of options by Groups, Option Number and Type as well as the Section reference for a detailed description of the option.

Where functional, physical or environmental requirements demand special configurations not possible with the standard options listed. Fincor offers Custom Engineered Controllers and Systems. Custom Engineered Controllers are subject to individual quotation and are manufactured to order. Consult factory for lead time and pricing.

TABLE 9. ALLOWABLE OPTION COMBINATIONS

| Remarks | Option Group | Option Number | Option | Type (4) | Mounted in Module (4) |
|--|--------------------------------------|---------------|---|----------|-----------------------|
| Feedback Options: Choice of one within this group unless Option 1037 is selected. Can be combined with Option selected from all groups except Group C. | A(1) | 1037 | Input and Feedback Interface Board | SP | Y(6) |
| | | 1061C | Feedback, Tachometer, AC or DC | SP | Y |
| | | 1062A | Feedback, Digital Pulse Generator | SP | Y |
| | | 1064 | Torque (Current) Limit Control | SP | Y |
| | | 1190 | Torque Taper | SP | Y |
| Input Options: Choice of one within this group unless Option 1037 is selected. Can be combined with Options selected from all groups except Group C. Note: (a) Specify AC Load Current - Current transformer must be separately mounted. | B(1) | 1034(Std) | Acceleration/Deceleration Linear | STD | Y |
| | | 1037 | Input and Feedback Interface Board | SP | Y(6) |
| | | 1049 | Follower, External DC Signal | SP | Y |
| | | 1050 | Follower, External AC Signal | SP | Y |
| | | 1050A(a) | Follower, AC Current Transducer | SP/SE | Y |
| | | 1051 | Follower, Master Isolated Reference Controller | SP | Y |
| | | 1055 | Follower, AC or DC Tachometer Generator | SP | Y |
| | | 1057A | Follower, Digital Pulse Generator | SP | Y |
| | | 1059 | Reference, Precision | SP | Y |
| 1065 | Isolator, Speed Potentiometer | SP | Y | | |
| Input and Feedback Options: Choice of one within this group. Can be combined with Options selected from all groups except Group A and B. | C(1) | 1064A | Follower, Current Regulator | SP | Y |
| | | 1191 | Centerwind Torque Taper | SP | Y |
| | | 1220 | Constant Velocity Winder | SP | Y |
| Miscellaneous Options: Choice of any or all within this group. Can be combined with options selected from any and all groups. Notes: (a) Requires Option 1076, Antiplug Protection (b) Line Reactor on Model 3121 and 3122 is mounted within the power module (c) Requires Option 1061C, Tachometer Feedback (d) Can only select 1029 or 1079, not both (e) Cannot be used with Options from Group B. (f) Does not include provisions for switching (g) Requires Option 1004 or 1004C (h) Can only select 1058 or 1058A, not both. | D(2) | 1011 | Circuit Breaker Handle and Enclosure Modification | s | n |
| | | 1018 | Fuses, Current Limiting | S | N(6) |
| | | 1019B(g) | Job, Reverse | S | N |
| | | 1024 | Preset Speed, (Independent, Adjustable) | S | N(6) |
| | | 1027(std) | Field Economy | STD | Y |
| | | 1029(c) | Field Regulator | S | N(6) |
| | | 1032 | Potentiometer, Motor Operated | S | N(6) |
| | | 1037A(g) | Input and Feedback Adapter, 1-Position | S | N(6) |
| | | 1037B(f) | Input and Feedback Adapter, 2-Position | S | N(6) |
| | | 1039(a) | Dynamic Braking | S | N |
| | | 1047(e) | Controlled (Ramp) Stop | S | N(6) |
| | | 1058(h) | Follower/Manual Mode Select (Relays) | S | N(6) |
| | | 1058A(h) | Follower/Manual Mode Select (Toggle-Switch) | SE | N |
| | | 1066 | Light, "Power On" | S | N(6) |
| | | 1067 | Light, "Motor On" | S | N(6) |
| | | 1070 | Meter, Load, Door Mounted | S | N(6) |
| | | 1070A | Meter, Speed Indicator (Analog), Door Mounted | S | N(6) |
| | | 1070B | Meter, Speed Indicator (Digital), Door Mounted | S | N(6) |
| | | 1072A | Auxiliary Contacts | S | N |
| | | 1073 | Test Meter | STD | Y |
| 1074(b) | Reactors, AC Line Inductors | S | Y(5) | | |
| 1076 | Antiplug Protection (APR) | SP | Y | | |
| 1077 | Field Loss Protection | S | N | | |
| 1079(d) | Field Power Supply, Constant Current | S | Y(6) | | |

(continued on next page)

TABLE 9. ALLOWABLE OPTION COMBINATIONS (Continued)

| Remarks | Option Group | Option Number | Option | Type (4) | Mounted in Module (4) |
|---|--------------|---------------|---|----------|-----------------------|
| (i) Can only select 1081B or 1081C, not both. (j) Can only select 1081B or 1081C, not both. | D(2) | 1081B(i) | Torque (Current) Monitor | S | N(6) |
| | | 1081C(i) | Torque (Current) Monitor, Inverse | S | N(6) |
| | | 1085 | Controller Less Enclosure | S | N |
| | | 1135 | Thermal Overload, Power Bridge | S | Y |
| | | 1139 | Enclosure, Larger NEMA 1 | S | N(6) |
| | | 1147 | Enclosure, Modification NEMA Type 12, Ventilated | S | N(6) |
| | | 1165 | Paint Finish, Special | S | N |
| | | 1166 | Manual, Instruction | — | N |
| | | 1170 | Fans, Power Bridge | S | Y |
| Reversing Options: Choice of one within this group. Can be combined with options selected from any and all groups. Note: (a) Requires Options 1076, Antiplug Protection | E(2) | 1004(a) | Reversing, Armature (Magnetic Control) | S | N |
| | | 1004C(a) | Reversing, Field | S | N(6) |
| Jog Forward Options: Choice of one within this group. Can be combined with options selected from any and all groups. | F(2) | 1019 | Jog, Forward (Push-Button Selection) | S | N |
| | | 1019A | Jog, Hard (Push-Button Selection) | S | N(6) |
| | | 1022 | Jog, Toggle-Switch Selection | SE | N |
| Thread and Crawl Options: Choice of one within this group. Can be combined with options selected from any and all groups. Note: (a) Requires Option 1061C. Tach Feedback. | G(2) | 1023 | Thread, (Preset, Independent, Adjustable) | S | N |
| | | 1023(a) | Crawl, (Preset, Independent, Adjustable) | S | N |
| Blower Motor Control Options: Choice of one within this group. Can be combined with options selected from any and all groups. Note: (a) Unit-cooled motors require two blower circuits. | H(2) | 1071(a) | Blower Motor Control | S | N(6) |
| | | 1071A(a) | Blower Motor Fuses | S | N(6) |
| Operator Control Options: Choice of any or all within this group. Can be combined with options selected from any or all groups. | K(3) | 1120 | Control Station | SE | N |
| | | 1120A | Potentiometer, Ten-Turn Motor Speed | SE | N |
| | | 1120B | Potentiometer, Single-Turn Motor Speed Assembly | SE | N |
| | | 1120C | Potentiometer, Ten-Turn Motor Speed Digital Counter | SE | N |

NOTES: (1) Options in Groups A, B and C can be furnished as factory installed or as field kits. Group A, B and C options are simple plug-in additions.

(2) Options in Groups D, E, F, G and H are offered as factory installed only unless they are listed in the 2910 Option Description Section in which case they can be furnished as factory installed or as field kits.

(3) Options in Group K are offered as field kits only for separate mounting.

(4) Codes: S – Standard Internal Mounted Option
SE – Standard External Mounted Option
SP – Standard Plug-In Internal Mounted Option
STD – Standard Feature
Y – Yes
N – No

(5) External to module in Models 3123 through 3127.

(6) Requires application engineering.

(7) See Option for a complete description of all options. The Option Description Section Number indicates the Section where the description is located.

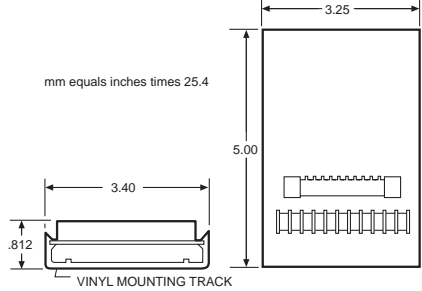
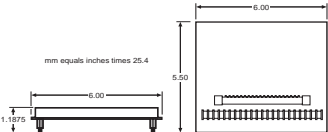
| Option Number | Description | | | | | | | | | | | | | | | | | | | | | | | | | | | | | |
|----------------------------|---|----------------------------|-------------------------------|--|-------------|-------------|-----|----|------|------|----|-----|------|----|-----|------|---|-----|-----|----|------|------|----|-----|------|----|-----|-------|---|-----|
| 1022 | <p>Jog, Toggle Switch Selection Option includes a RUN-JOG selector switch and a JOG SPEED potentiometer for installation in the operator control panel. The RUN-JOG toggle switch (maintained) contacts in the operator station open the contactor seal-in circuit. Controller then jogs when the RUN pushbutton is pressed and held at the JOG SPEED potentiometer setting.</p> <p>Jog action is momentary, causing motor rotation only when the RUN pushbutton is depressed. This option is also suitable for reversing units where identical forward and reverse jog speeds are acceptable.</p> | | | | | | | | | | | | | | | | | | | | | | | | | | | | | |
| 1034 | <p>Acceleration/Deceleration, Linear Permits simple potentiometer adjustments of solid-state timing circuits to establish a desired time span to attain a preset speed. The speed change is linear with respect to time, and is effective any time the speed control potentiometer is changed, not just from start-up. Acceleration and deceleration rates are independently adjustable from 1 to 30 seconds. This option is a suggested method of accelerating high inertia loads, for controlling the slowdown of high friction loads, matching the acceleration and deceleration rates of multiple drives, and other applications where acceleration and deceleration are critical.</p> <p>Where high inertia loads are encountered, the deceleration control may be limited, as the coast time may exceed the programmed deceleration time.</p> <p><i>Option 1034 consists of a small plug-in circuit board which inserts into the INPUT connector of the control circuit board.</i></p> | | | | | | | | | | | | | | | | | | | | | | | | | | | | | |
| 1037 | <p>Feedback/Input Adapter, Interface Board Signal input or feedback circuit boards plug directly into the control board of the controller. Some applications require multiple operating modes with the ability to selectively track two or more external reference signals, i.e., a tachometer signal or an external DC signal. This option provides an extender circuit board with a terminal strip which replaces the standard input or feedback board. This brings the internal regulator circuits of the control board to screw terminal connection points. The input or feedback boards are mounted externally from the controller and wired through selection logic to the external input or feedback interface terminal board.</p> | | | | | | | | | | | | | | | | | | | | | | | | | | | | | |
| 1037A | <p>Feedback/Input Adapter, 1-Position Provides an assembly capable of accepting either a standard input option board or a feedback option board.</p> <p><i>Option 1037A consists of a vinyl mounting track with P.C. socket and terminal board.</i></p>  | | | | | | | | | | | | | | | | | | | | | | | | | | | | | |
| 1037B | <p>Feedback/Input Adapter, 2-Position Provides an assembly capable of accepting feedback and input boards or a double width board containing both the feedback and input function (i.e., Option 1191).</p> <p><i>Option 1037B consists of a base with P.C. socket and terminal board.</i></p>  | | | | | | | | | | | | | | | | | | | | | | | | | | | | | |
| 1049 | <p>Follower, External DC Signal Provides necessary impedance matching circuitry to interface a customer supplied DC signal source with the drive controller reference input. Typical applications are those where motor speed must be controlled as a function of a process variable such as temperature, weight, flow, pressure, etc.</p> <p>In many applications, the reference signal is obtained from a process instrument controller or other commercially available transducer with a DC milliamper output. Devices of this type normally provide signal levels compatible with requirements listed in the table:</p> <p>Included are suitable adjustments for linear transfer of instrument output current to motor speed. The adjustments will normally be set so minimum transducer signal results in minimum or zero motor speed. Also provided is an adjustment to extend or compress the transducer signal output so a 5:1 transducer output signal range, for example, could provide a 10:1 or 20:1 drive speed range. Included are individual potentiometer adjustments for:</p> <table border="1" data-bbox="859 1528 1401 1871"> <thead> <tr> <th rowspan="2">DC Input Signal Range (mA)</th> <th colspan="2">Option Input Impedance (Ohms)</th> </tr> <tr> <th>Option 1049</th> <th>Option 1052</th> </tr> </thead> <tbody> <tr> <td>0-5</td> <td>80</td> <td>1000</td> </tr> <tr> <td>0-10</td> <td>40</td> <td>500</td> </tr> <tr> <td>0-25</td> <td>16</td> <td>200</td> </tr> <tr> <td>0-50</td> <td>8</td> <td>200</td> </tr> <tr> <td>1-5</td> <td>80</td> <td>1000</td> </tr> <tr> <td>2-10</td> <td>40</td> <td>500</td> </tr> <tr> <td>4-20</td> <td>16</td> <td>250</td> </tr> <tr> <td>10-50</td> <td>8</td> <td>250</td> </tr> </tbody> </table> | DC Input Signal Range (mA) | Option Input Impedance (Ohms) | | Option 1049 | Option 1052 | 0-5 | 80 | 1000 | 0-10 | 40 | 500 | 0-25 | 16 | 200 | 0-50 | 8 | 200 | 1-5 | 80 | 1000 | 2-10 | 40 | 500 | 4-20 | 16 | 250 | 10-50 | 8 | 250 |
| DC Input Signal Range (mA) | Option Input Impedance (Ohms) | | | | | | | | | | | | | | | | | | | | | | | | | | | | | |
| | Option 1049 | Option 1052 | | | | | | | | | | | | | | | | | | | | | | | | | | | | |
| 0-5 | 80 | 1000 | | | | | | | | | | | | | | | | | | | | | | | | | | | | |
| 0-10 | 40 | 500 | | | | | | | | | | | | | | | | | | | | | | | | | | | | |
| 0-25 | 16 | 200 | | | | | | | | | | | | | | | | | | | | | | | | | | | | |
| 0-50 | 8 | 200 | | | | | | | | | | | | | | | | | | | | | | | | | | | | |
| 1-5 | 80 | 1000 | | | | | | | | | | | | | | | | | | | | | | | | | | | | |
| 2-10 | 40 | 500 | | | | | | | | | | | | | | | | | | | | | | | | | | | | |
| 4-20 | 16 | 250 | | | | | | | | | | | | | | | | | | | | | | | | | | | | |
| 10-50 | 8 | 250 | | | | | | | | | | | | | | | | | | | | | | | | | | | | |

| | |
|----------------------------|--|
| <p>1049 (Cont.)</p> | <p>MINIMUM SPEED (Override) — Adjustable by the MOTOR SPEED potentiometer to establish a minimum drive speed independent of the external reference signal. The MOTOR SPEED potentiometer is also used as a manual speed setting control when no external reference signal is present. See Figure A. A MANUAL/FOLLOWER selector switch is therefore unnecessary for most applications and is not included with this option. See Option 1058A when a switch is required. The MOTOR SPEED potentiometer is mounted in the operator control station.</p> <p>IMPEDANCE MATCH — Provides a means of matching the impedance of the signal source. Also functions as a GAIN adjustment as shown by Figure B.</p> <p>OFFSET — See Figure B for adjustment range.</p> <p>IMPEDANCE MATCH and OFFSET potentiometers are mounted on the Option Circuit Board.</p> <p>This option does not provide signal isolation. It is therefore not recommended for use with units which have non-isolated regulators such as Series 3135 drive controllers unless:</p> <p>(a) The signal source is ungrounded and isolated. (b) The drive controller is isolated from the AC line with an isolation transformer when the control signal is grounded. (c) The drive controller is isolated from the AC line with an isolation transformer whenever the control signal is also connected to the control input terminals of any other drive controller(s) with non-isolated regulator(s).</p> <p><i>Whenever these conditions are not practical, Option 1052 is suggested for single drive applications, and Option 1051 with the MIRC master controller is suggested for multiple drive systems.</i></p> <p><i>Option 1049 consists of a small plug-in circuit board which inserts into the INPUT connector of the control circuit board.</i></p> <p><i>Option 1049 does not include the external signal source, Motor Speed potentiometer or optional Manual Follower selector switch.</i></p> |
| <p>1050</p> | <p>Follower, External AC Signal</p> <p>Provides necessary impedance matching, isolation, signal conversion and filtering as required to adjust the speed of the drive (or drives) from an external AC signal source. Option 1050 permits full range speed control from an external 0 to 115 VAC adjustable signal source manually controlled by a potentiometer, variable autotransformer or some other suitable means.</p> <p>This option is required for each controller which is to be controlled by the external AC signal.</p> <p>Included in this option are minimum and maximum speed adjustments, with the normal drive run speed potentiometer functioning as a ratio setting when following the external AC signal. This option is useful for multiple section machines where a definite speed relationship must be maintained between sections, while the entire machine is varied over a specified speed range by a common manual speed control device.</p> <p>This option consists of a small plug-in circuit board which inserts into the input connector of the control board.</p> <p><i>The option does not include the external AC signal source.</i></p> |
| <p>1050A</p> | <p>Follower, AC Current Transducer</p> <p>Intended for automatic control systems where it is necessary for the drive to follow an AC signal proportional to the load current of an AC constant speed, induction motor. Typical examples are conveying systems where the material feed rate has a direct influence over the loading of the AC motor, i.e. the carriage or conveyor feeding logs to a saw powered by an AC motor. Since the thickness and density of the wood is not uniform this option permits automatic adjustment of conveyor speed to the highest feed rate which will not overload the saw motor.</p> <p>In order that a proper current transformer may be supplied it is necessary that nameplate data such as horsepower, voltage, load current, etc. be provided from the AC motor.</p> <p>This illustration shows an application which requires an inverse relationship between AC motor load current and the follower drive motor speed. This option may also be programmed for a direct relationship where the follower drive would increase in speed with increasing AC motor load current. Included are independent controls and adjustments for:</p> <p>AUTO/MANUAL SELECTOR SWITCH (1) — Selects the operation function. When the switch is in AUTO position, the drive functions as an AC current follower unit. When the switch is in MANUAL position the drive functions as an adjustable speed unit. When the AUTO function is selected, the separately furnished Motor Speed potentiometer provides speed adjustment of the DC motor at a ratio from 0 to 100% of the AC input signal. When the MANUAL function is selected, the Motor Speed potentiometer provides normal manual speed adjustment of the DC motor.</p> <p>DIRECT/INVERT SLIDE SWITCH (2) — Selects the operation mode. When the switch is in DIR position, the speed of the DC drive motor varies directly proportional to the load current drawn by the AC motor. When the switch is in INVT position the speed of the DC drive motor varies inversely proportional to the AC motor load current, i.e., when the load of the AC motor increases causing it to draw more current, the DC motor speed decreases.</p> <p>BIAS (2) — Set the maximum DC motor speed for the INVERT mode of operation.</p> <p>CURRENT SCALING (2) — Matches the range of the AC input signal to the input signal range requirements of the controller.</p> <p>INTEGRATION RATE (2) — Sets the response rate of the system when the AUTO function is selected.</p> <p>MINIMUM SPEED (2) — Sets minimum speed independently of the input control signal.</p> <p>PROPORTIONAL GAIN (2) — Sets the gain of Circuit Board when the AUTO function is selected.</p> <p><i>This option consists of:</i></p> <p><i>a. Toroidal current transformer for separated mounting by the user for sensing AC motor load current</i> <i>b. A small plug-in circuit board which inserts into the input connector of the control circuit board.</i> <i>c. AUTO/MANUAL selector switch for mounting remotely.</i></p> <p>Notes: (1) Mounted in operator control station. (2) Located on circuit board</p> |

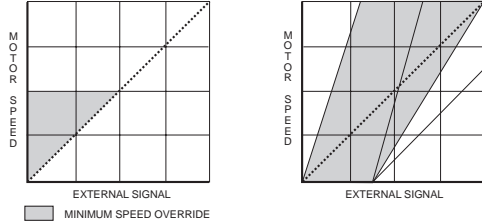
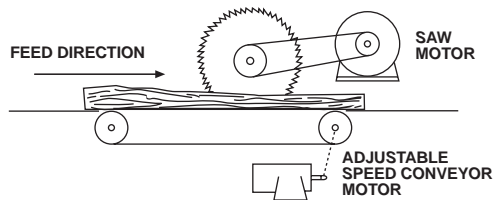
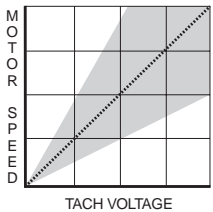
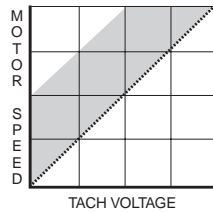
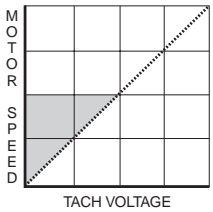

FIGURE A

FIGURE B



| Option Number | Description |
|---------------|---|
| 1051 | <p>Follower, Master Isolated Reference Controller (MIRC) Provides an input circuit board to interface a controller with speed reference signals transmitted by the Model MIRC101 master controller. The receiver circuit board includes necessary isolation impedance matching and frequency to analog conversion.</p> <p>This option is required for each controller whenever one or more is to be controlled by the MIRC101. Option 1051 includes adjustments for maximum ratio, minimum speed and offset as well as the separately furnished MOTOR SPEED potentiometer. The MIRC101 is a versatile master controller suggested for use whenever isolation is required between a controller and a grounded external signal source and/or signal isolation is required between multiple controllers which must track a common speed reference signal.</p> <p>All adjustments excepting the MOTOR SPEED potentiometer are mounted on the option circuit board. The MOTOR SPEED potentiometer functions as a manual speed setting device with the MASTER/LOCAL selector switch in the LOCAL position. In the MASTER position this potentiometer provides a ratio or draw adjustment.</p> <p>See Standard Specification 7140 for additional information on the MIRC101 Master Controller.</p> <p><i>Option 1051 consists of a small plug-in circuit board which inserts into a prewired connector provided for this purpose and a MASTER/LOCAL selector switch.</i></p> <p><i>This option does not include the MIRC101 Master Controller or the MOTOR SPEED potentiometer.</i></p> |
| 1055 | <p>Follower, AC or DC Tachometer Generator Intended for automatic control systems where it is necessary for the drive to follow the speed of a preceding drive unit or rotating machine coupled to an AC or DC tachometer generator. The tachometer voltage signal provides the speed reference for the "follower" drive.</p> <p>Option 1055 is not recommended for use where multiple drive controllers are required to operate from a common signal source, unless the controllers are isolated. A more economical approach if the controllers are not isolated would be the use of the MIRC101 master isolated reference controller which is intended for use with multiple drive controllers. See Option 1051.</p> <p>Adjustments are provided to adapt the unit to a wide range of system requirements. Included are independent adjustments for:</p> <p>TACH SCALING — Adjustable to interface the tachometer generated voltage with the required controller reference voltage when the FOLLOWER RATIO potentiometer is set on maximum. If a plus ratio is required (i.e.: the follower drive is at full speed when the master drive is at half speed) set the FOLLOWER RATIO potentiometer at its midpoint and adjust TACH SCALING for the required controller reference voltage and then adjust the FOLLOWER RATIO potentiometer toward 100.</p> <p>FOLLOWER RATIO — Adjustable to permit tracking the tachometer signal voltage at a plus or minus ratio. See Figure 1. The FOLLOWER RATIO potentiometer is mounted in the operator control panel.</p> <p>MINIMUM SPEED (additive) — Adjustable to permit tracking the tachometer signal at a fixed offset voltage. See Figure 2. MINIMUM SPEED ADDITIVE potentiometer is mounted on the Option 1055 circuit board.</p> <p>MINIMUM SPEED (Override) — Adjustable by the MOTOR SPEED potentiometer to establish a minimum drive speed independent of tachometer signal voltage. The MOTOR SPEED potentiometer is also used as a manual speed setting control when no tachometer signal is present. See Figure 3. The MOTOR SPEED potentiometer is mounted in the operator control station.</p> <p>A MANUAL/FOLLOWER selector switch is therefore unnecessary for most applications and is not included with this option. See Option 1058A when a switch is required. The MOTOR SPEED potentiometer is mounted in the operator control station.</p> <p><i>Option 1055 consists of a small plug-in circuit board which inserts into the INPUT connector of the Control Circuit Board and a FOLLOWER RATIO potentiometer for separate mounting.</i></p> <p><i>This option does not include the tachometer generator which must provide 30 volts at base speed and not to exceed 180 volts at maximum speed.</i></p> <div style="display: flex; justify-content: space-around; align-items: flex-end;"> <div style="text-align: center;">  <p>FIGURE 1. Tach Scaling and Follower Ratio</p> </div> <div style="text-align: center;">  <p>FIGURE 2. Minimum Speed Additive</p> </div> <div style="text-align: center;">  <p>FIGURE 3. Minimum Speed Override</p> </div> </div> |

| Option Number | Description |
|---------------------|---|
| <p>1057A</p> | <p>Follower, Digital Pulse Generator This option provides signal conditioning and isolation for accepting a signal from a magnetic pulse pick-up mechanically coupled to a preceding drive motor, rotating machinery or various static pulse generators permitting the drive to follow at an adjustable ratio.</p> <p><i>This option consists of:</i></p> <ol style="list-style-type: none"> Digital to analog conversion circuit board which inserts into the INPUT connector of the control circuit board. A signal conditioning circuit board which is mounted in the base of the controller or remotely mounted. MANUAL/FOLLOWER selector switch for separate mounting. Interconnection wire harness. <p>Two modes of operation are provided: Manual and Follower, as selected by the MANUAL/FOLLOWER switch. In the Manual mode, the MOTOR SPEED potentiometer controls motor speed. In the Follower mode, the motor follows the digital pulse signal, and the MOTOR SPEED potentiometer functions as the follower ratio adjust potentiometer.</p> <p>The signal conditioner circuit board accepts the output of any one of the following devices:</p> <ol style="list-style-type: none"> Magnetic pulse pick-up capable of providing 450 pulses/second at motor base speed and not exceeding a maximum of 2500 pulses/second at motor base speed. Recommended input: 100 tooth gear on a 1150 RPM motor. 60 tooth gear on a 1750 RPM motor. 30 tooth gear on a 2400 RPM motor. Pulse generator (TTL) with a 0 to +5V output, capable of providing a minimum of 450 pulses/second at motor base speed and not exceeding a maximum of 2500 pulses/second at motor base speed. Pulse generator with an open collector output, capable of conducting 2 milliamperes at 24VDC. <p><i>This option does not include the magnetic pick-up assembly, pulse gear or other signal source, or the MOTOR SPEED potentiometer.</i></p> |
| <p>1058A</p> | <p>Manual/Follower Mode Select (Toggle Switch) This option is intended as a companion to Option 1055, Option 1049 and Option 1052.</p> <p>Options 1055, 1049 and 1052 do not include a selector switch and rely upon a zero speed setting of the MOTOR SPEED potentiometer to transfer to full automatic control by the external signal. Option 1058A, when used with these options, allows manual switch selection of either the MOTOR SPEED potentiometer or automatic control by the external signal.</p> <p><i>Option 1058A includes a switch with a MANUAL/FOLLOWER legend plate for installation in the operator control panel.</i></p> |
| <p>1059</p> | <p>Reference, Precision This option provides a high stability, precision reference circuit that replaces the function of the standard internal reference circuit in the drive controller. This circuit offers important benefits for critical applications where sensitivity to operating variables such as load changes, temperature, line voltage variations, etc. must be held to an absolute minimum. This option may be used in combination with Option 1061C, Feedback, Tachometer AC or DC.</p> <p><i>This option consists of a small plug-in circuit board which replaces the standard input board.</i></p> |
| <p>1061C</p> | <p>Feedback, Tachometer AC or DC Provides impedance matching and terminals for accepting a signal from a 2 phase AC or DC tachometer generator, mechanically coupled to the drive motor armature. The tachometer signal defeats the IR compensation circuitry in the drive controller making the unit directly sensitive to motor speed. This results in expanded speed range, improved speed regulation with load changes, and reduced sensitivity to operating conditions such as line voltage variations, ambient temperature changes, motor field heating and other operating variables. The controller will automatically switch to armature feedback if the tachometer signal is lost.</p> <p>Tachometer generator must provide 30 to 180 volts at maximum motor speed. A MAXIMUM SPEED TACHOMETER potentiometer is provided to scale the tachometer signal.</p> <p><i>Option 1061C consists of a small plug-in circuit board which inserts into the FEEDBACK connector on the control circuit board, replacing the armature feedback circuit board. Option 1061C does not include the tachometer generator.</i></p> |

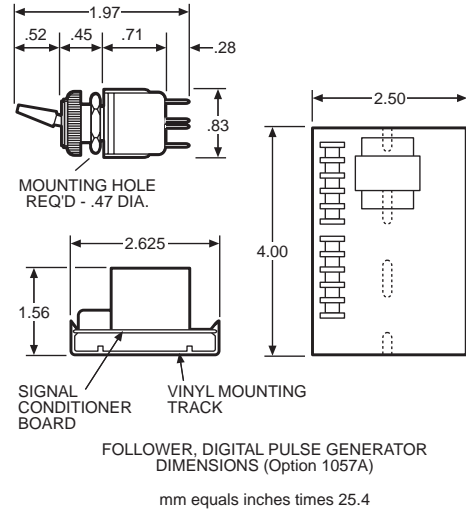

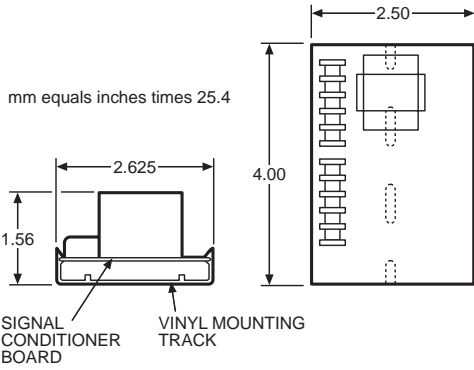
| Option Number | Description |
|---------------|---|
| 1062A | <p>Feedback, Digital Pulse Generator Provides signal conditioning and isolation for accepting a signal from a magnetic pulse pick-up mechanically coupled to the drive motor armature. The magnetic pulse pick-up must provide a minimum of 450 pulses per second at motor speed (60 tooth gear on a 1750 RPM motor). The pulse pick-up signal defeats the IR compensation circuitry in the drive controller, making the unit directly sensitive to motor speed. Speed range is limited to 35:1.</p> <p>The option results in improved speed regulation with load changes (equal to DC tachometer feedback) and reduced sensitivity to operating conditions such as line voltage variations, ambient temperature changes, motor field heating and other variables.</p> <p><i>Option 1062A consists of:</i></p> <ol style="list-style-type: none"> Digital to analog conversion circuit board which inserts into the FEEDBACK connector of the control circuit board. A signal conditioner circuit board which is mounted on the base of the controller or remotely mounted. This option does not include the pulse pick-up assembly.  |
| 1064 | <p>Torque (Current) Limit Control Provides the ability to adjust the drive current limit setting and thus the motor torque over a range of 50-150% by a remote mounted TORQUE ADJUST potentiometer. (See Option 1190).</p> |
| 1064A | <p>Follower, Current Regulator Provides a means of controlling motor armature current and torque by a manually adjusted potentiometer or an external DC voltage reference signal. The circuit includes internal isolation permitting direct connection to a grounded signal source or the armature circuit shunt of another DC drive controller. Since torque is directly controlled independent of motor speed, provision is included for limiting maximum motor speed.</p> <p>Multiple motor applications typically involve a master speed regulated drive which establishes the speed of the system and one or more current regulated follower drive units. The follower units obtain their current reference signal from the master controller. Typical applications include:</p> <ol style="list-style-type: none"> Load sharing between two or more drive units with their motors mechanically coupled. Load sharing between two or more drive units coupled by the process material itself such as steel bar stock being pulled by multiple drive units through separately powered sections of a machine. Tension control of a web of process material being transferred between sections of a multiple section machine. <p>APPLICATION INFORMATION</p> <ol style="list-style-type: none"> Current Response time Zero to full-load current 150 Milliseconds Output Current Control Range 10:1 Signal input required for maximum current output Range 1 3.35 to 36.5 VDC Range 2 0.34 to 3.7 VDC Range 3 0.04 to 0.44 VDC Transfer linearity Input signal to output current 1% <p><i>This option consists of a plug-in circuit board which inserts into both input and feedback connectors of the control board. Included are separate adjustments for:</i></p> <p>Maximum Speed 0-Motor Base Speed Maximum Current 0-150% of rated (1) Input Scaling Adjustable to match the input signal (0.04 to 36.5 VDC) for maximum current output Current offset Adjustable for zero current output with minimum signal output. (1) 0-75% of rated achieved by adjustment of the unit current limit.</p> |
| 1065 | <p>Isolator, Speed Potentiometer Provides isolation between the MOTOR SPEED potentiometer and the controller. Suggested for applications where the potentiometer must be isolated from the controller or mounted more than 100 ft. (30m) from the controller. This option consists of a circuit board which plugs into the INPUT connector of the control circuit board.</p> |
| 1081B | <p>Torque (Current) Monitor Provides an adjustable, static circuit that monitors motor armature current and provides a programmed shutdown of the drive under sustained overload conditions to prevent motor damage. The circuit provides greater versatility than the standard, non-adjustable overload circuit calibrated to trip whenever armature current exceeds 120% for 80 seconds.</p> <p>The static overload circuit supplements the protective benefits of the controller current limit and motor thermostat. It is especially effective in preventing motor damage when:</p> <ol style="list-style-type: none"> The motor is subjected to high torque loads at low speeds. |

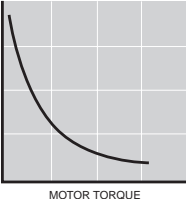
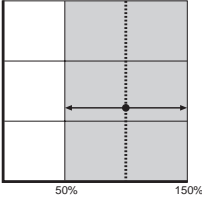
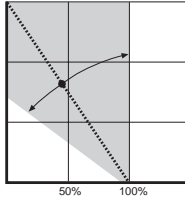
| Option Number | Description |
|-----------------------|---|
| 1081B (cont'd) | <p>Torque (Current) Monitor</p> <p>b. The current limit allows adjustments to 150% of rated armature current. Standard 1.0 service factor motors are rated for 1 minute of operation at this load. Damage or reduced motor life may result if sustained for longer periods since the current limit functions independent of time.</p> <p>c. The motor is forced cooled and must run at speeds below 50% base speed for any sustained period of time.</p> <p>Circuit includes one set of Form C, 2 amp, 120 VAC or 28 VDC rated relay contacts that may be used to signal audible or visual alarms or auxiliary control devices such as lubrication pumps, fans or valves.</p> <p>Circuit includes two adjustments:</p> <p>1. "THRESHOLD" (trip current level) 10-180% Rated Armature Amps 2. "DELAY" (time at trip current level) 1-90 seconds</p> <p>The threshold adjustment establishes the amount of armature current necessary to initiate the timing period set by the delay circuit. When the current remains above the threshold level for a period equal to the delay time setting, the relay energizes.</p> <p>The accuracy of the current monitor is not affected by ambient temperature changes within the design operating limits of the drive controller.</p> |
| 1120 | <p>Control Station</p> <p>Provides a standard model numbered remote control station for separate mounting by the user. Control elements are provided mounted within the station and wired to a terminal board.</p> |
| 1120A | <p>Potentiometer, Ten-Turn Motor Speed (Analog Dial)</p> <p>Provides a ten-turn, 2W potentiometer, knob and analog counting dial for separate mounting by user. See Specification 7100; Table 2 for selection by product series, Figure 2 for dimensions.</p> |
| 1120B | <p>Potentiometer, Single-Turn Motor Speed Assembly</p> <p>Provides a single-turn, 2W potentiometer, knob and dial wired to a terminal board for separate mounting by user. See Specification 7100; Table 5 for selection by product series, Figure 4 for dimensions.</p> |
| 1120C | <p>Potentiometer, Ten-Turn Motor Speed (Digital Dial)</p> <p>Provides a ten-turn, 2W potentiometer, knob and digital counting indicator dial assembly for separate mounting by user. See Specification 7100; Table 5 for selection by product series, Figure 6 for dimensions.</p> |
| 1190 | <p>Torque Taper</p> <p>Center driven winders ideally require a reciprocal speed torque relationship (constant horsepower) to maintain constant tension throughout the range of material buildup as illustrated by Figure 1. Acceptable performance can be economically achieved for many applications with an inverse-linear speed-torque relationship provided by this option. Tension control accuracy of approximately 20% can normally be maintained from empty to full roll at a given production machine speed.</p> <p><i>This option consists of a plug-in circuit board which inserts into the FEEDBACK connector of the control circuit board, and a TORQUE ADJUST potentiometer prewired for installation in the operator control panel. Independent potentiometers are provided for:</i></p> <p>TORQUE ADJUST — Establishes maximum low speed torque as illustrated by Figure 2. The TORQUE ADJUST in combination with the SLOPE ADJUST establishes the torque available at any point throughout the operating speed range. The TORQUE ADJUST potentiometer is mounted in the operator control panel.</p> <p>SLOPE ADJUST — Establishes the slope or rate of linear torque increase with decreasing speed, throughout the operating range. Adjustable from 0 to 100% torque at maximum motor speed with minimum effect on low speed torque. See Figure 3. The SLOPE ADJUST potentiometer is mounted within the controller on the option circuit board.</p> <p>Use caution in the selection of motors for center driven windup applications where torque loads increase in inverse proportions to motor speed. Web break or other process material detectors are recommended to prevent a dangerous over-speed should the process material break.</p> <p><i>Option 1190 normally provides acceptable performance in applications where the material being wound travels a constant speed during winder roll buildup. If the process is such that the speed of the material being wound varies during winder roll buildup or if more accurate tension control is desired, see Option 1191.</i></p> <p><i>Option 1190 can also be used for constant torque applications where conventional operation of the current limit is required and remote mounting of the torque (current) potentiometer is desired. When used in this manner, the Slope adjustment is set for a vertical cut-off of motor (maximum setting) torque (current).</i></p> <div style="display: flex; justify-content: space-around; align-items: flex-end;"> <div style="text-align: center;">  <p>MOTOR TORQUE</p> </div> <div style="text-align: center;">  <p>50% MOTOR TORQUE 150%</p> </div> <div style="text-align: center;">  <p>RPM 50% MOTOR TORQUE 100%</p> </div> </div> <p>FIGURE 1. "Ideal" Constant HP Curve for a Winder Application.</p> <p>FIGURE 2. Torque Adjust with Taper Adjust at Maximum.</p> <p>FIGURE 3. Taper Adjust with Torque Adjust at 100% Torque Setting.</p> |

| Option Number | Description | | | | | | |
|---------------------------------------|--|----------------------------------|------------------------|---------------------------------------|----|--|-------------|
| 1191 | <p>Centerwind Torque Control</p> <p>This option offers a more sophisticated solution to controlling the tension of center driven winders than Torque Taper Option 1190. Tension control is more accurate since this option produces a reciprocal speed-torque relationship which closely matches the ideal constant horsepower curve required to maintain constant tension.</p> <p>Option 1191 has provisions to accept a signal proportional to web speed from either a tachometer generator driven from the production machine feeding the winder or a potentiometer ganged to the production machine speed control. Tension control accuracy of better than 20% can normally be maintained from empty to full roll; and the control automatically compensates for changes in production machine speed.</p> <p><i>This option consists of a plug-in circuit board which inserts into both the INPUT and the FEEDBACK connectors of the control board, and a TORQUE ADJUST potentiometer pre-wired for installation in the operator control panel. Included are independent potentiometer adjustments for:</i></p> <p>TORQUE ADJUST — Sets the desired tension in the material being wound. This potentiometer is mounted in the operator control panel.</p> <p>TACH SCALING (1) — Scales the production machine tachometer signal voltage to the control requirements.</p> <p>MAX TORQUE EMPTY ROLL (1) — Establishes the torque required to maintain proper tension at high winder speed.</p> <p>MAX TORQUE FULL ROLL (1) — Establishes the torque required to maintain proper tension at low winder speed.</p> <p>TORQUE BOOST TIME (1) — Establishes the time that additional torque is supplied to accelerate the winder when the production machine speed is increased.</p> <p>Use caution in the selection of motors for center driven windup applications where torque loads increase in inverse proportion to motor speed. Also, web break or other process material detectors are recommended to prevent a dangerous overspeed should the process material break.</p> <p>An AC or DC tachometer generator with a minimum output of 30 volts at base speed and not exceeding 180 volts at maximum production machine speed or a 5K ohm potentiometer ganged to the production machine speed control is required, but not furnished as part of this option.</p> <p>(1) These potentiometers are mounted on the option circuit board.</p> | | | | | | |
| 1220 | <p>Constant Velocity Winder</p> <p>This option provides an economical but accurate method of automatically controlling the tension of process material in strip, web, wire or cable form as wound by a center driven winder.</p> <p>As shown by the figure below, the option requires the use of a DC tachometer generator coupled to the process material by nip rolls, a pressure roller or capstan in a manner that will provide a continuous feedback of the velocity of the process material.</p> <p>A manually set MOTOR SPEED potentiometer establishes the desired line speed of the process material. As material builds up on the winder core, the diameter increases which would tend to increase the line speed of the material. This will produce a higher voltage output from the tachometer generator which will cause the drive motor and winder to slow down to maintain a constant velocity and uniform winder tension.</p> <p>Should a break occur in the process material, this option will automatically transfer to an adjustable minimum take up speed to minimize damage to the product and winder machinery.</p> <p>RATINGS</p> <table border="0"> <tr> <td>1. Regulation Accuracy</td> <td>2% of motor base speed</td> </tr> <tr> <td>2. Maximum Line Speed Range</td> <td>30</td> </tr> <tr> <td></td> <td style="text-align: right;">Build Ratio</td> </tr> </table> <p>Example: a 3:1 build ratio (3 ft. dia. full roll, 1 ft. dia. empty roll) = 10:1 line speed range.</p> <p>3. MOTOR SPEED potentiometer 5,000 ohms</p> <p><i>The option consists of a plug-in circuit board which inserts into both the INPUT and the FEEDBACK connectors of the control board. Included are independent potentiometer adjustments for :</i></p> <p>ADJUSTMENTS</p> <ol style="list-style-type: none"> 1. Take-Up Speed 0 to 50% of maximum speed 2. Maximum Speed Set maximum range of MOTOR SPEED potentiometer 3. Acceleration (Response Time) 1-60 sec. <p>Use caution in the selection of motors for center driven windup applications where torque loads increase in inverse proportion to motor speed.</p> <p>A DC Tachometer Generator with a minimum output of 1.0 volt at base speed and not to exceed 120 volts at maximum production machine speed and a 5K MOTOR SPEED potentiometer are required but not furnished as part of this option.</p> <div data-bbox="860 1512 1396 1764" style="text-align: center;"> </div> | 1. Regulation Accuracy | 2% of motor base speed | 2. Maximum Line Speed Range | 30 | | Build Ratio |
| 1. Regulation Accuracy | 2% of motor base speed | | | | | | |
| 2. Maximum Line Speed Range | 30 | | | | | | |
| | Build Ratio | | | | | | |