



INSTRUCTION MANUAL

DOCUMENT NO. 027 -0175
Rev. 1.04 Sept. 16, 2003

***Sleep Function + Reference Loss
Detection + Over / Under Torque
Detection Option Card Kit
for the GP10 / VG10
Part Number 100-0175-01***

Saftronics, Inc.

5580 Enterprise Pkwy
Ft. Myers, FL 33905
Tel. (239) 693 - 7200
Fax (239) 639 - 2431
www.saftronics.com

+

SAFETY FIRST !

LETHAL VOLTAGES MAY BE PRESENT

PLEASE READ THIS MANUAL THOROUGHLY BEFORE ATTEMPTING ANY INSTALLATION, OPERATION, MAINTENANCE, OR INSPECTION. FAILURE TO FOLLOW THE RECOMMENDED PROCEDURES OR CAUTIONS IN THIS MANUAL COULD RESULT IN INJURY TO PERSONNEL AND / OR DAMAGE TO THE EQUIPMENT.

CAUTION

- 1 – CHECK THE NAME WRITTEN ON THE PRODUCT AND INSURE THAT THE PROPER PART HAS BEEN RECEIVED.
- 2 – THOROUGHLY INSPECT THE PART(S) FOR ANY DAMAGE DUE TO SHIPMENT OR HANDLING.
- 3 - THE PART(S) MAY CONTAIN CMOS CHIPS AND CAN BE DAMGED BY STATIC ELECTRICITY. HANDLING SHOULD BE IN ACCORDANCE WITH INDUSTRY STANDARDS.
- 4 - BEFORE INSTALLING THE PART(S) TURN OFF ALL POWER TO THE EQUIPMENT AND INSURE THE CHARGE INDICATOR LAMP ON THE INVERTER IS **OFF**. **LETHAL VOLTAGES ARE PRESENT**
- 5 - DO NOT CONNECT OR DISCONNECT WIRING WHILE POWER IS **ON!**
- 6 - FOLLOW GOOD STANDARD WIRING PRACTICES AND ANY APPLICABLE CODES THAT MAY APPLY.

Contents

	<i>Page</i>
1.0 Overview	3
1.1 Specification summary	3
1.2 Kit contents	3
<i>Fig. 1 Product appearance</i>	<i>4</i>
1.3 Terminal functions	5
<i>Table 1 Terminal and settings</i>	<i>5</i>
<i>Fig. 2 Basic connection diagram</i>	<i>5</i>
2.0 Installation	6
2.1 General	6
<i>Fig. 3 30 HP or less</i>	<i>7</i>
<i>Fig. 4 40 HP and above</i>	<i>8</i>
2.2 Wiring	6
3.0 Operation and Programming	9
3.1 Sleep Function	9
<i>Fig. 5 Sleep Function connection diagram</i>	<i>9</i>
3.2 Reference Loss Detection Function	10
<i>Fig. 6 Reference Loss connection diagram</i>	<i>10</i>
3.3 Torque Detection Function	11
<i>Fig. 7 Torque Detection connection diagram</i>	<i>11</i>

Sleep Function + Ref. Loss Detection + Over / Under Torque Detection Option Card

P/N 100 – 0175 – 01

1.0 OVERVIEW

The **100 – 0175 – 01** Option Card is designed for use with the **Saftronics GP10 / VG10** Inverter series. It monitors three independent input functions, and provides three form C dry contact relay outputs for control purposes. Each function can be enabled or disabled by a dipswitch setting. The levels and time for the Sleep Function and the High / Low Torque Level Detection are set by on board potentiometers for ease of setup. LED indicators show the active state of the various functions.

1.1 Specification Summary

Inputs Signals :

FB – Reference (positive)
REF - Reference (positive)
TRQ – Torque (positive)
GND – Signal common

Input Signal Voltage / Current - 0 – +10 VDC **or** 0 – 20 mA / 4 – 20 mA (jumper selectable)
Input Resistance – 10 KOHM (voltage input)
Input Resistance – 500 OHM (current input)

Relay Outputs - (3) Form C Contact Rated at 120 VAC @ 0.5 A / 24VAC @ 1.0 A.

Potentiometer Settings:

Sleep Level - 0 – 100%
Sleep Time- 0 – 25 Seconds
High Torque Level- 0 – 100%
Low Torque Level- 0 – 100%
Torque Detection Time- 0 – 25 Seconds

Environmental - See GP10 / VG10 Manual

1.2 Kit Includes

(1) 100-0175-01 OPTION CARD
(3) P/N 026-6008 SUPPORTS
(1) P/N 020-0212 M3-6 SCREW

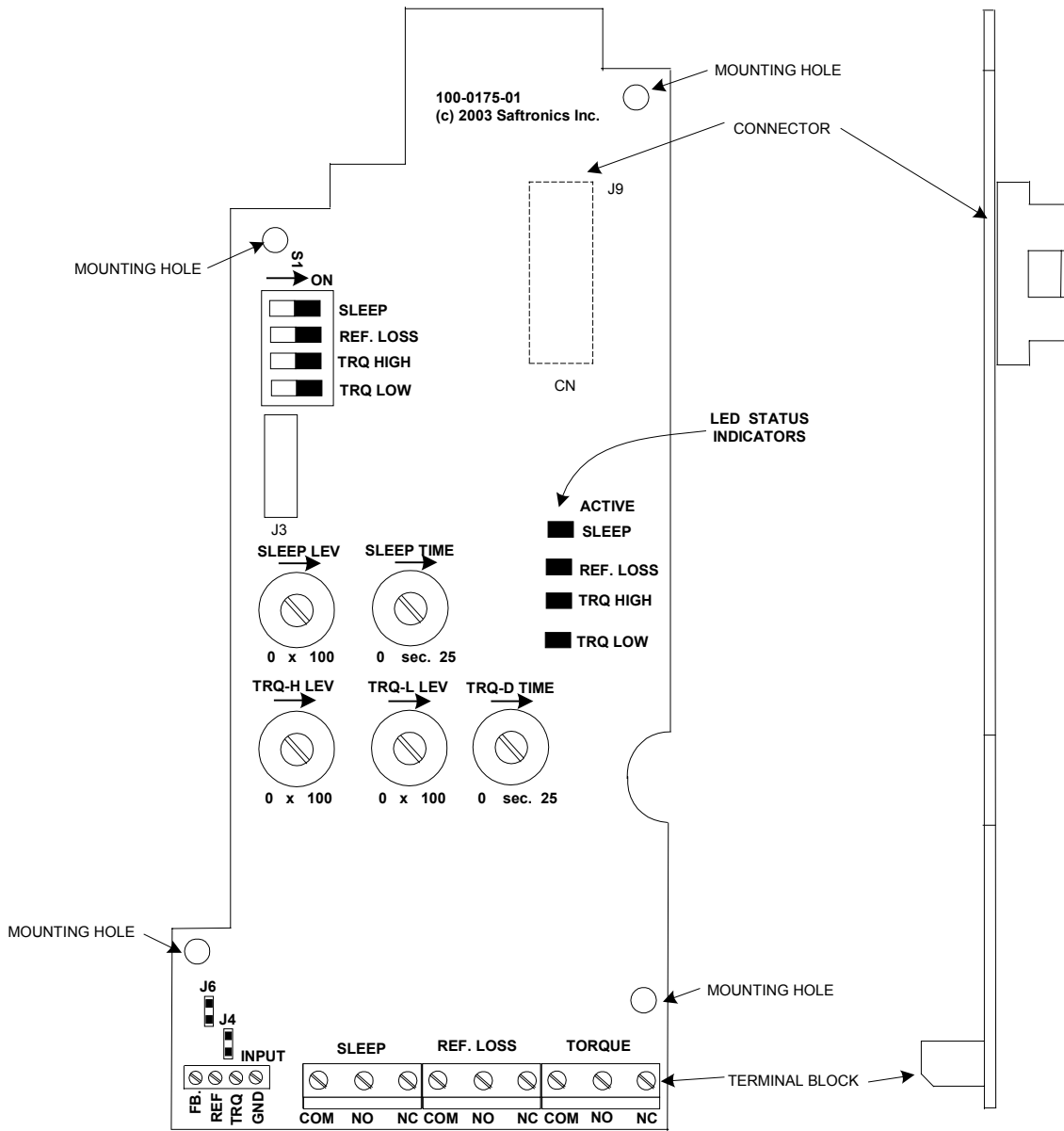

Fig. 1 Product Appearance

1.3 Terminals and settings

Table 1 Terminals and Settings

		Function	
Terminals			
FB	Reference (Positive)		
REF	Reference (Positive)		
TRQ	Torque (Positive)		
GND	Analog ground		
Jumpers			
J6	FB input signal	0 - +10 VDC	Jumper OUT
		0 - 20 mA / 4 - 20 mA	Jumper IN
J4	REF input signal	0 - +10 VDC	Jumper OUT
		0 - 20 mA / 4 - 20 mA	Jumper IN
Switch Settings			
1	ON	Sleep function enabled	
2	ON	Reference loss detection enabled	
3	ON	Over torque detection enabled	
4	ON	Under torque detection enabled	
Pot Settings			
Sleep Lev	Sets the sleep function level from 0 – 100%. The range is equal to the analog input applied to terminal FB		
Sleep Time	Sets the the sleep function detection time from 0 – 25 Sec.		
TRQ-H LEV	Sets the over torque detection level from 0 – 100%. The range is equal to the analog input applied to terminal TRQ .		
TRQ-L LEV	Sets the under torque detection level from 0 – 100%. The range is equal to the analog input applied to terminal TRQ .		
TRQ-D TIME	Sets the torque detection time from 0 – 25 Sec.		

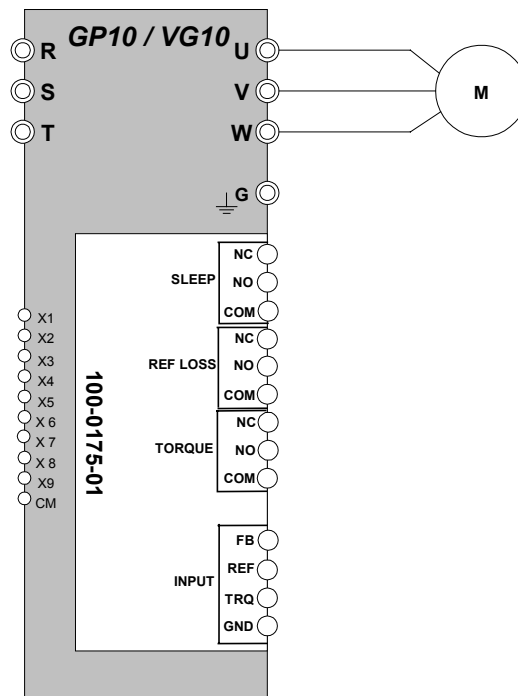

Fig. 2 Basic Connection Diagram

2.0 INSTALLATION

Please read this manual in its' entirety before attempting any installation!

2.1 General

Turn off all power to the equipment being worked on before attempting any installation. Fig. 1 Shows the appearance of the option card. Ensure that the proper option card has been received along with the accessories listed and that no damage has occurred to the parts.

Following **Fig. 3** or **Fig. 4**, install the option card for the **GP10 / VG10** Inverter HP ranges listed. Using good standard practices, and in accordance with applicable codes, make the connections to the option card in accordance with **Fig. 2**, Basic Wiring Diagram, and the application requirements. Use the following wiring guidelines to insure optimum performance.

2.2 Wiring

CAUTION

- Check the wiring before operating the drive. Improper wiring may cause unexpected drive operation or device operation. **There is a risk of accident or injury.**
- ❑ **Do not connect the GND analog terminal of the option card to earth ground or damage to the card will result**

Wiring the Option Card

- Use a shielded cable for wiring the drive option.
- Connect the sheath of the shielded cable to the terminal **G** of drive only, and leave the other end open.
- Run the option wiring at least 4" (10 cm) from the main circuit wiring of the drive main unit and other power cables to avoid abnormal operation due to noise. **Do not** run the option wiring in the same electrical duct with other power cables.

Terminal Connection on Option Card

The wire size range that the option card connection terminal(s) can accommodate, is AWG: 16-26.

Referring to the figure below, strip the wire back about 1/4 " (6 mm) and make the connection to the terminals by inserting wire into the upper side of the metal bracket on the terminal block, and tighten the screw.

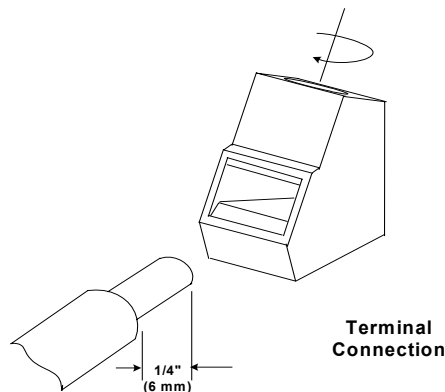

VG10 30HP or less

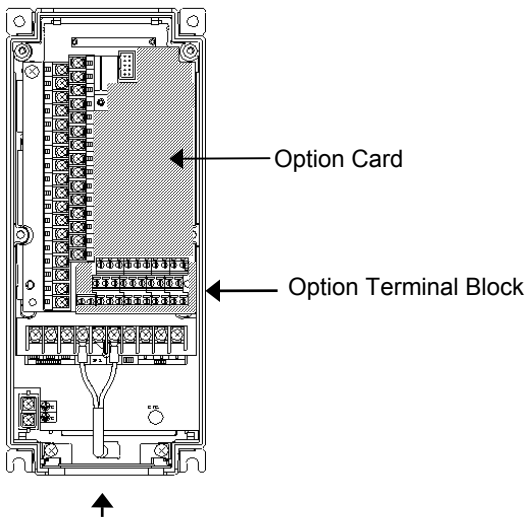
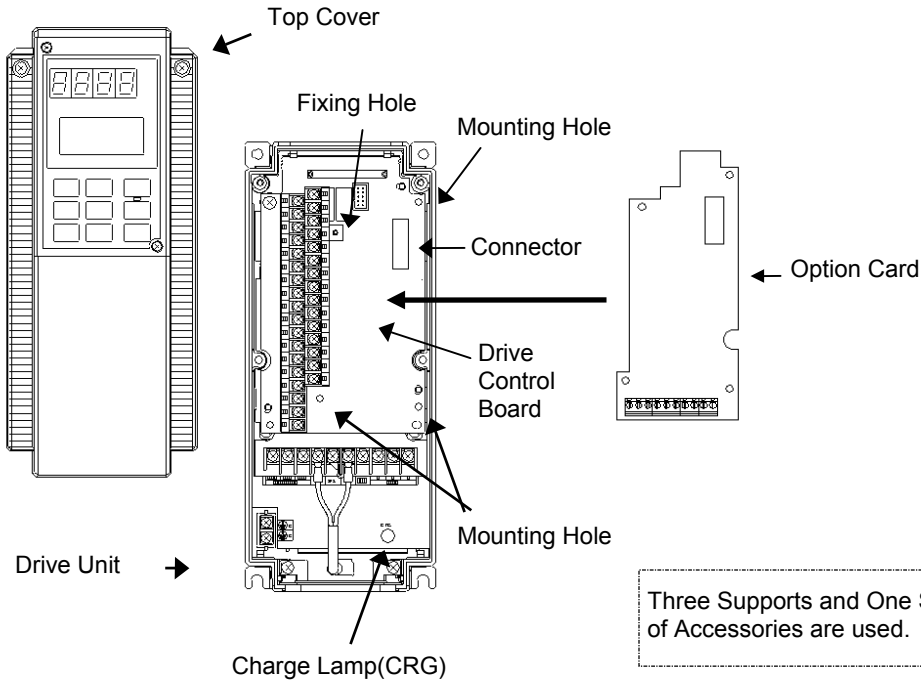

Step 1

Remove the top cover, and insert the accessory supports into the three mounting holes on the Drive control Board.

Step 2

Set the supports inserted in step 1 on the option card, and insert the Drive control board connector to the option card connector. After that, check that you can see the pins of the supports on the option card.

Step 3

Insert and tighten the screws (M3 x 6) in the fixing holes to secure the option card.

Step 4

Wire the option according to the basic connection diagram.

Fig. 3 30 HP or Less

VG10 40 HP and above

Two Supports and One Screw of Accessories are used.

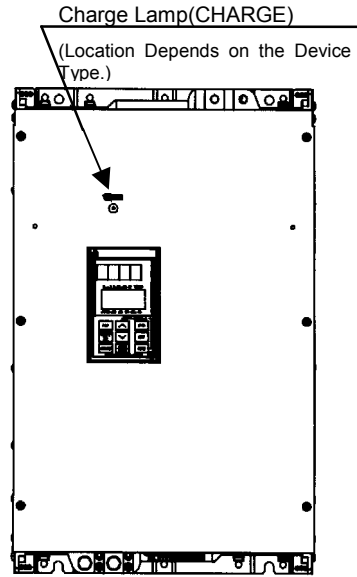
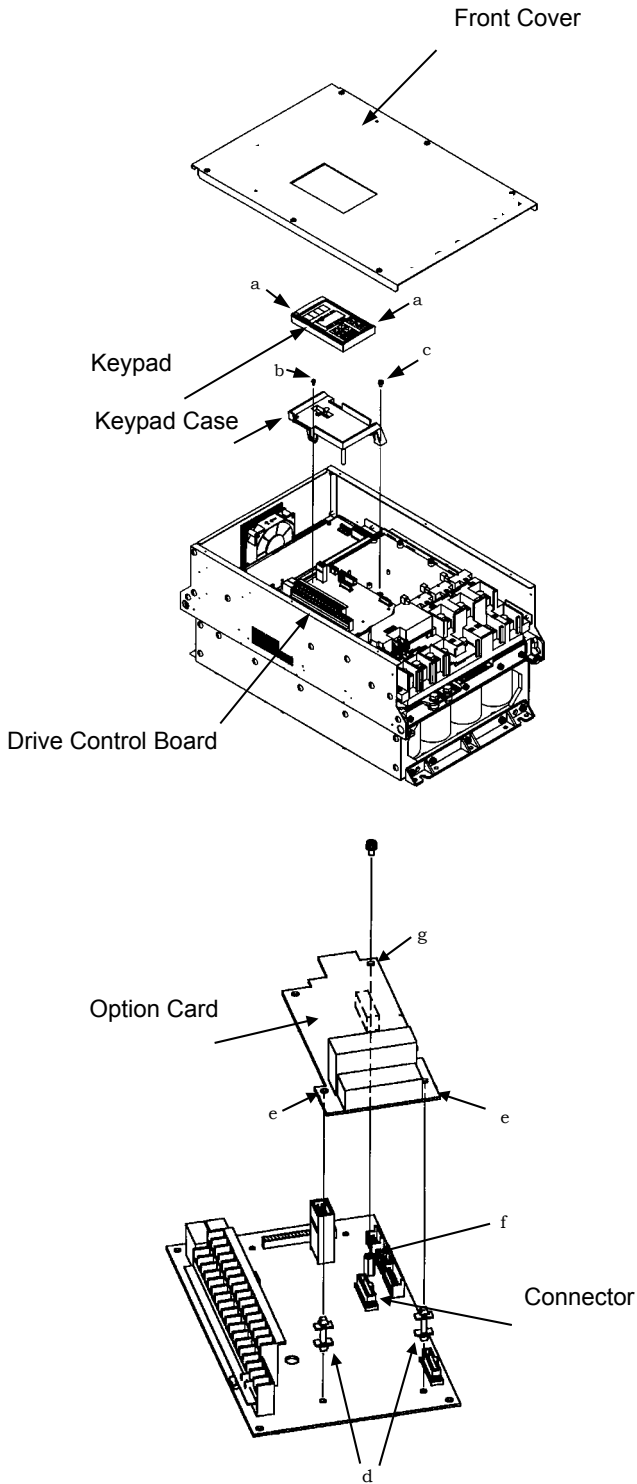

Step 1

Remove the front cover and loosen the two M3 screws (a) to remove the keypad panel.

Step 2

Remove one M3 screw (b) and one M4 screw (c) to remove the keypad panel case.

Step 3

Insert the two accessory supports (d) into the drive control board.

Step 4

Insert the two supports (d) into the holes (e) on the option card. Align the support (f) with the hole (g) on the option card, then and insert one connector.

Step 5

Insert and tighten the accessory screws (M3 x 6) at (f) and (g) to secure the option card.

Step 6

Replace the keypad panel, case, keypad, and the front cover. then reassemble the drive.

Fig. 4 40 HP and Above

3.0 Operation & Programming

The various option card functions may be used independently or together to achieve a specific control scheme for a particular application. The following sections will discuss each function separately and it will be left to the user to select the proper combination to achieve the desired result.

3.1 Sleep Function

Note: The Sleep Function can only be used with a remote reference, where F01 = 01.

The PID sleep function can be used to prevent the drive from outputting a low frequency, possibly causing damage to the equipment. The function has a dedicated Form C output relay that can be connected in series with the drive run command, to the digital input terminals of the drive, or to a remote device to achieve a specific control mode. The status LED for this function turns on when the function is active.

To set up this function, turn **S1 SLEEP** of the dipswitch **ON**. Connect the reference positive to terminal **FB** of the input and analog **GND**. This reference signal may be 0 – +10 VDC or a 0 – 20 mA / 4 – 20 mA which is jumper selectable (**J6**). The sleep function level potentiometer, (**SLEEP LEV**) sets the level, 0 – 100%, of the value of the signal applied to **FB** where the **SLEEP** output relay turns on. The sleep time potentiometer, (**SLEEP TIME**) sets the time, 0 – 25 seconds, when the **SLEEP** output relay turns **ON and OFF**.

As an example, referring to **Fig. 5**, If a 0 - + 10vdc signal is applied to the **FB** terminal, and the **SLEEP LEV** pot is set to 50% with the **SLEEP TIME** pot set at 10 Sec., the **SLEEP** output relay would turn **ON** when the **FB** signal fell below +5 VDC for more than 10 seconds.

In the case of Terminal Operation where the drive parameter **F02** is set to **2**, the forward run command would be disabled through the **NC** relay contact in series with the **FWD** drive terminal and the drive would not operate. The **SLEEP** output relay would then stay on and the drive would not run until the **FB** signal increased above +5 VDC for more than 10 seconds.

When keypad operation is selected, **F02** is set to **0**, and terminal **X1** is put in series with the **NO** relay contact of the **SLEEP** output relay with drive parameter **E01** is set to **7** (Coast to stop)

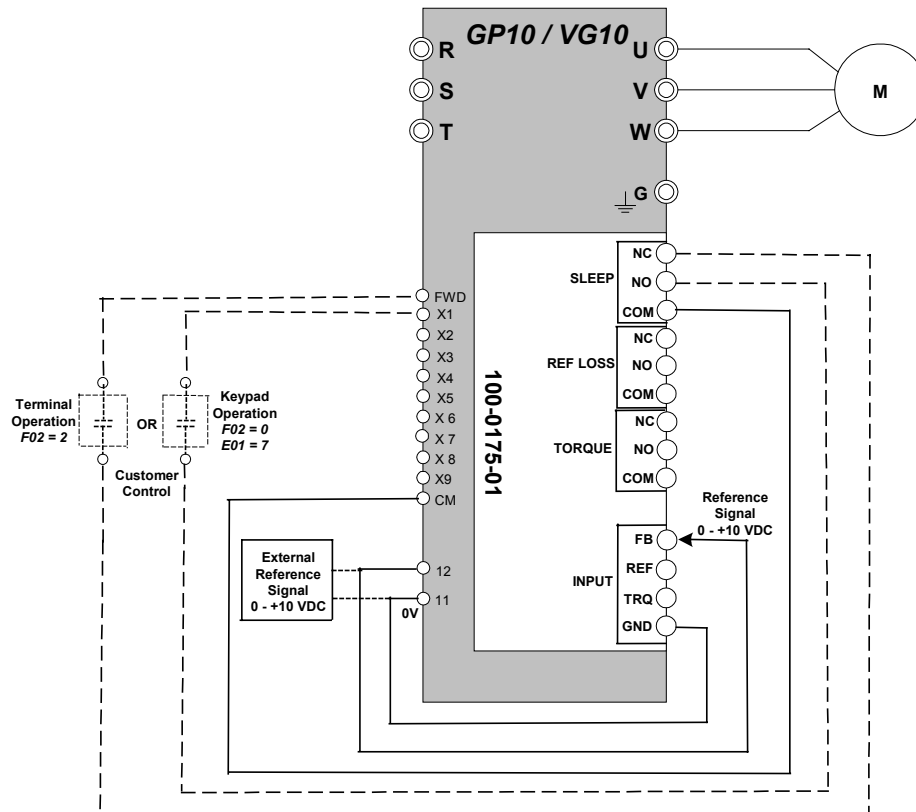

Fig. 5 Sleep Function Connection Diagram

3.2 Reference Loss Detection Function

The reference loss function can be used to prevent the system from operating or running at maximum frequency. The option card detects a reference loss when the input signal to **REF** falls below 80% of its' **set** value for more than 200ms. A form C output relay activates that can be connected to the digital input terminals of the drive, or to a remote device to achieve a specific control mode. The status LED for this function also turns on. When the reference restores and reaches 10% of **full scale** value (Ex. +10 VDC) the reference fault loss is cleared.

To set up this function, turn **S2 REF LOSS** on the dipswitch to **ON**. Connect the reference positive to terminal **REF** of the input and analog ground **GND**. This reference signal may be 0 – +10 VDC or a 0 – 20 mA / 4 – 20 mA which is jumper selectable (**J4**).

As an example, referring to **Fig. 6**, If it were desired to maintain a predefined reference frequency after reference loss, the following scheme could be used.

Assuming a **GP10** drive, Connect the reference to the **REF** input terminal and analog ground **GND**. Connect the **NO** contact and **COM** of the **REF LOSS** relay to **X1** and **CM** of the **GP10s'** digital input. Set the **GP10** program parameter **C05** (multi-step frequency) to the desired output frequency upon reference loss.

In operation, the drives' output frequency will follow the signal input to **REF**. If the reference, for example is set for +5 VDC and is lost, the function will detect the loss when the signal falls below +1 VDC (80% of **set** value) for more than 200 ms. The **REF LOSS** relay will active and the drive will operate at the frequency set by parameter **C05**. When the reference restores, and reaches 1 VDC (10% of **full scale**) the **REF LOSS** relay will deactivate and normal operation will resume. (Note: The relay may be cleared if the reference is not restored by turning the dipswitch S2 OFF then ON.)

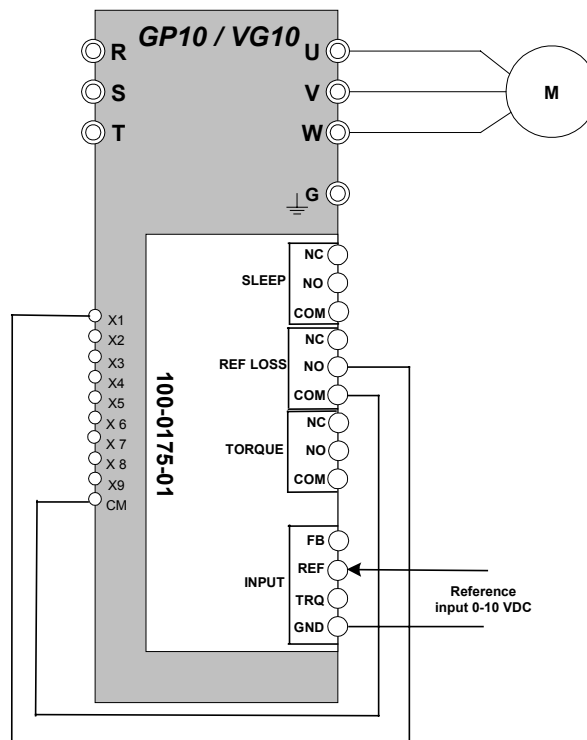

Fig. 6 Reference Loss Connection Diagram

3.3 Torque Detection Function

The torque detection function provides over and under torque detection that can be used to prevent damage to the equipment. The function has a dedicated Form C output relay that can be connected in series with the drive run command, to the digital input terminals of the drive, or to a remote device to achieve a specific control mode. The status LED(s) for this function turns on when the function is active.

To setup this function, turn **S3 TRQ – H** of the dipswitch **ON** for over torque detection and / or **S4 TRQ – L ON** for under torque detection. Referring to **Fig. 7**, connect the torque signal positive terminal, **TRQ** of the input, to the **FMA** analog output terminal of the drive. Connect the analog ground terminal **GND** to analog terminal **11** of the drive. Set the **F31** parameter of the drive to **4** (Torque output). Using the **(TRQ – H)** potentiometer set the desired over torque detection level from 0 – 100%. Set the **(TRQ – L)** potentiometer for the desired under torque detection level, 0 – 100%. The time delay for the **TORQUE** output relay to activate when the set torque limit(s) is exceeded, is set by the **(TRQ – D TIME)** potentiometer from 0– 25 seconds.

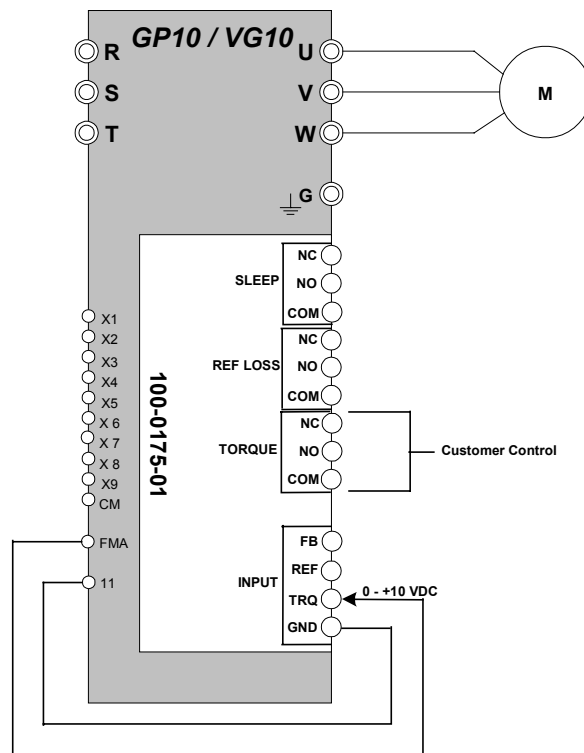

Fig. 7 Torque Detection Connection Diagram

WARNING!

Saftronics manufactures component parts that can be used in a wide variety of industrial applications. The selection and application of *Saftronics* products remains the responsibility of the equipment designer or end user. *Saftronics* accepts no responsibility for how it's products may be incorporated into the final design.

Under no circumstances should any *Saftronics* product be incorporated into any product or design as the exclusive or sole safety control. Without exception, all controls should be designed to dynamically fault detect and fail safe under all circumstances. All products designed to incorporate a component part manufactured by *Saftronics*, must be supplied to the end user with appropriate warnings and instructions as to the safe use and operation. Any warnings provided by *Saftronics* must be passed through to the end user.

Saftronics offers an express warranty only as to the quality of it's products to conform to the catalog specifications. NO OTHER WARRANTY, EXPRESS OR IMPLIED, IS OFFERED. *Saftronics* assumes no liability for any personal injury, property damage, losses or claims, arising out of the mis-application of it's products.