



MODBUS PLUS OPTION CARD

SOPC-G11S-MBP

FOR GP10 & VG10

INSTRUCTION MANUAL

Saftronics, Inc.

5580 Enterprise Pkwy., Ft. Myers, FL 33905

Telephone: (239) 693-7200

Fax: (239) 693-2431

www.saftronics.com

Document Part Number 027-2153

REV June 2002

REVISION NOTES

Date:	Document	Notes:
2000.01.28	Revision 0.10	Created by Fredrik Risberg
2000.02.03	Revision 0.11	Edit by Fredrik Risberg
2000.04.25	Revision 0.12	Edit by MaS and FrR
2000.05.09	Revision 0.13	Edit by FrR

PREFACE

The data and illustrations found in this document are not binding. We reserve the right to modify our products in line with our policy of continuous product development. The information in this appendix is subject to change without notice and should not be considered as a commitment by HMS INDUSTRIAL NETWORKS AB.

HMS INDUSTRIAL NETWORKS AB assumes no responsibility for any errors that may appear in this document.

The product and technology described in this document is patent pending in the following countries:

USA, Canada, Japan, Belgium, Denmark, Finland, France, Greece, Ireland, Italy, Luxemburg, Monaco, Netherlands, Portugal, Switzerland, Lichtenstein, Spain, United Kingdom, Sweden, Germany and Austria.

ANYBUS® is a registered trademark of HMS INDUSTRIAL NETWORKS AB.
All other trademarks are the property of their respective holders.

RELATED DOCUMENTS

Document	Author
GP10 Instruction Manual P/N 027-GP1001 VG10 Instruction Manual P/N 027-VG1001	SAFTRONICS, INC.

TABLE OF CONTENTS

Revision Notes	1
Preface	1
Related documents	1
1. Applicable inverters	4
2. Receiving Inspection	5
3. Installation	6
3.1 Installation Method	6
3.2 Installation Checklist	7
4. Modbus Plus option card SOPC-G11S-MBP	8
5. Introduction to Modbus Plus	8
5.1 Technical features of Modbus Plus	8
6. SOPC-G11S-MBP Overview	10
6.1 Physical interface	10
6.2 Configuration	10
6.2.1 Node ID Switch 1	11
6.2.2 Source ID Switch 2	11
6.2.3 Changeover of communications	12
6.2.4 DATA MAP I/O CONFIG	14
6.2.5 Global Data Input Offset, Parameter o30	14
6.2.6 Number of Global Data Inputs words, Parameter o31	15
6.2.7 Number of Global Data words producing, Parameter o32	15
6.2.8 Configuration of Global Data / Data Map I/O	16
6.2.9 Safety Register	18
6.3 Action at communication error	19
6.4 Indication LED's	22
7. Operating the drive via Modbus Plus	23
7.1 Global Data (I/O Data Map)	23
7.2 Example	24
7.3 Example	25
7.4 Parameter Read/Write	26
7.4.1 Exception responses	26
7.4.2 Point-to-point parameter usage	27
7.4.3 Setting the Routing Path	27
7.4.4 Read Holding Registers	27
7.4.5 Preset Multiple Registers	28

7.4.6	Preset Single Register28
7.4.7	Example28
7.4.8	Memorizing history of written parameters29
8.	Parameters specific for communication29
8.1	Command data29
8.2	Operation command data30
8.3	Function data32
8.4	Monitoring data33
8.5	Parameter data format36
8.6	Data format specification42

1. APPLICABLE INVERTERS

Item	Description		
Inverter type	Saftronics GP10 / VG10		
Compatible Inverter Model number (Saftronics)	The last two digits of the model number should be B1 or later Example: 6KG1123X1B1		
Minimum inverter ROM version number	up to 22 kW(30HP)	EN version	S08000 and after (It is impossible to use version prior to S08000 inverter.)
		Japanese standard, JE and CN version	Cannot be used
		UX and Saftronics	S08000 and after (It is impossible to use version prior to S08000 inverter.)
	30 kW(40HP) and above	EN, Japanese standard, JN, JE, AN, CN, UX and Saftronics	H07602 and after H00000 to H07601.)

NOTE:

This product can only be used for Inverters with ROM version numbers greater than or equal to the versions shown above.

And in the case of installing this option in the GP10 / VG10 inverter that is a Japanese standard, JN, JE or CN version, please contact Saftronics or its distributors.

Check the ROM number of your Inverter as follows using the inverter keypad.

- a. Check that the Inverter Operation monitor (Operation mode) screen is displayed.
- b. Press the [PRG] key of the Inverter once.
- c. Select the "5. MAINTENANC" with the cursor and press the [FUNC/DATA] key.
- d. Press the down cursor key to increment the display at the MAINTENANC screen.
Finally, the ROM number is shown in the maintenance information, as indicated by the display "INV=Hxxxxx or Sxxxxx".

The maintenance and inspection items are similar to the Inverter unit, for detail refer to the Inverter Instruction Manual.

2. RECEIVING INSPECTION

Confirm the following items upon a receipt.

- 1) The model number matches your purchase order?

Model: SOPC - G11S - MBP

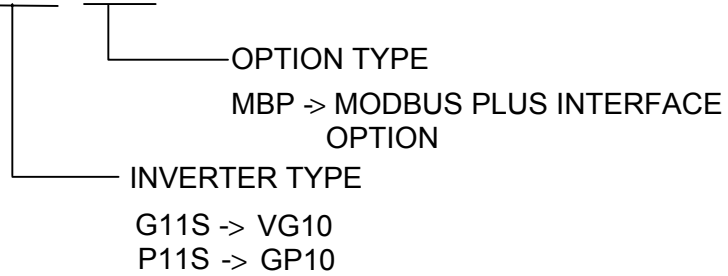

Check the model number printed on the circuit board.

- 2) Inspection for damage during transportation. Report damage to transportation carrier.

3. INSTALLATION

3.1 INSTALLATION METHOD

Please follow the installation procedure described as follows. Please install or detach the option after turning off the input power supply of the inverter and confirming the charge lamp (CHARGE or CRG) is gone out.

The shape, the dimensions and the position of the charge lamp of the inverter are different by each capacity.

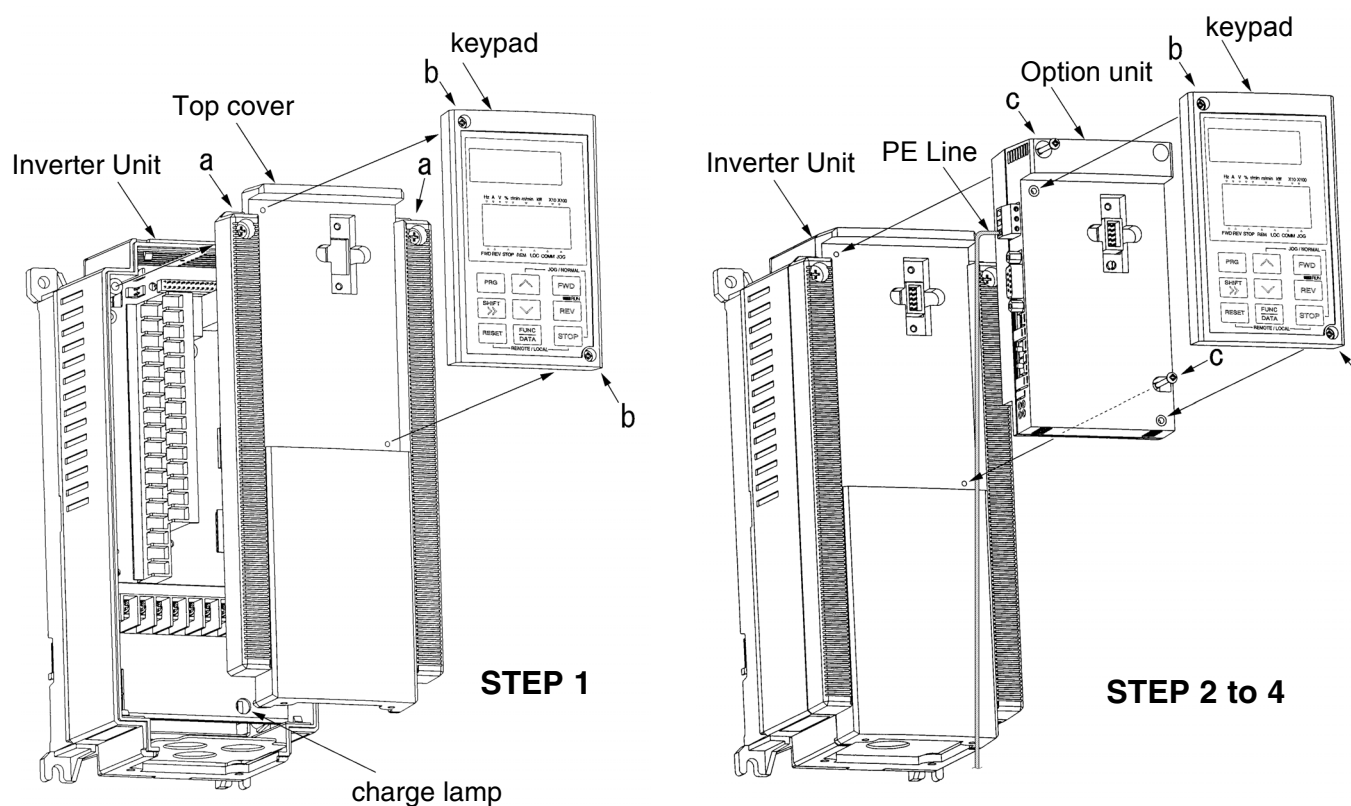

Step 1

Loosen two screws(M4) at a and remove the top cover. Loosen two screws (M3) at b and detach the keypad panel. (For the 30kW [40HP] and above inverters, the keypad panel can be detached if the front cover is removed and the screws loosened at b.)

Step 2

Reassemble the top cover, push-in the option unit and secure it with two screws (M3) at c.

Step 3

Secure the keypad panel to the option unit with two screws at b.

Step 4

Connect the ground cable to the PE terminal of the option unit.

3.2 INSTALLATION CHECKLIST

After installation and wiring, check the following items.

- [1] The wiring is correct.
- [2] No loose wires or screws remain inside the Inverter.
- [3] The screws and terminals are all tight.
- [4] There are no loose threads of wires at terminals that may contact other terminals.
- [5] The switch positions on the Anybus-S module, JP6 on the conversion-board are suitable for the use purpose. (Do not change the JP4 on the conversion-board !)
- [6] Inverter parameters such as H30, o27, o28, o30 to o52, are set correctly. (H30: Link Active/Inactive, o27 and o28: for RAS, o30 : Global data input offset, o31: Number of global data inputs words, o32: Number of global data words producing: o33 to o52: for I/O data mapping).

4. MODBUS PLUS OPTION CARD SOPC-G11S-MBP

The SOPC-G11S-MBP option card gives an instant connection between Safronics GP10 / VG10 drives and Modbus Plus. The option board will perform as an integrated part of the G11S drive and gives the user access to all relevant parameters, as well as control-/status signals needed to control the drive

The SOPC-G11S-MBP option card communicates according to the Modbus Plus Protocol. This means that it can communicate with all Modbus Plus nodes that comply with this protocol, but it does not necessarily mean that all services available in the Modbus Plus protocol is supported. The functionality in this Modbus Plus device is all general services, relevant for speed and control.

In a control system the SOPC-G11S-Modbus Plus option card will act as a slave that can be read and written to, from another Modbus Plus node such as a Controller or Host device. It will not initiate communication to other nodes, it will only respond to incoming telegrams, except for producing Global Data available for every device in the network section.

5. INTRODUCTION TO MODBUS PLUS

Modbus Plus is a local area network system designed for industrial control applications, developed by Modicon, Inc. HMS is a member of the ModConnect program for developing Modbus Plus devices.

Technical questions regarding the fieldbus should be addressed to Modicon Inc. at www.modicon.com.

Modbus Plus is normally used in industrial automation, to transfer fast data for motor controllers, MMI, I/O units and other industrial equipment.

5.1 TECHNICAL FEATURES OF MODBUS PLUS

- Physical media: EIA RS 485 twisted pair cable.
- Baud rate: 1.0 Mbaud.
- Maximum number of nodes / Network: 32 (with repeaters 64 nodes).
- Total end-to-end length of the network cable is 450m (without repeaters).
- Maximum number of I/O: 32 words / slave (in the same network).
- Bus topology: Virtual token ring communication. The figure below gives an overview of a Modbus Plus network.
- Cyclic user data can be transferred between all nodes in the same network.
- Connecting or disconnecting stations without affecting other stations.
- Uses a chip-set from Modicon handling the Modbus Plus communication.
- All messages are FM modem encoded - decoded into Biphase-S data.

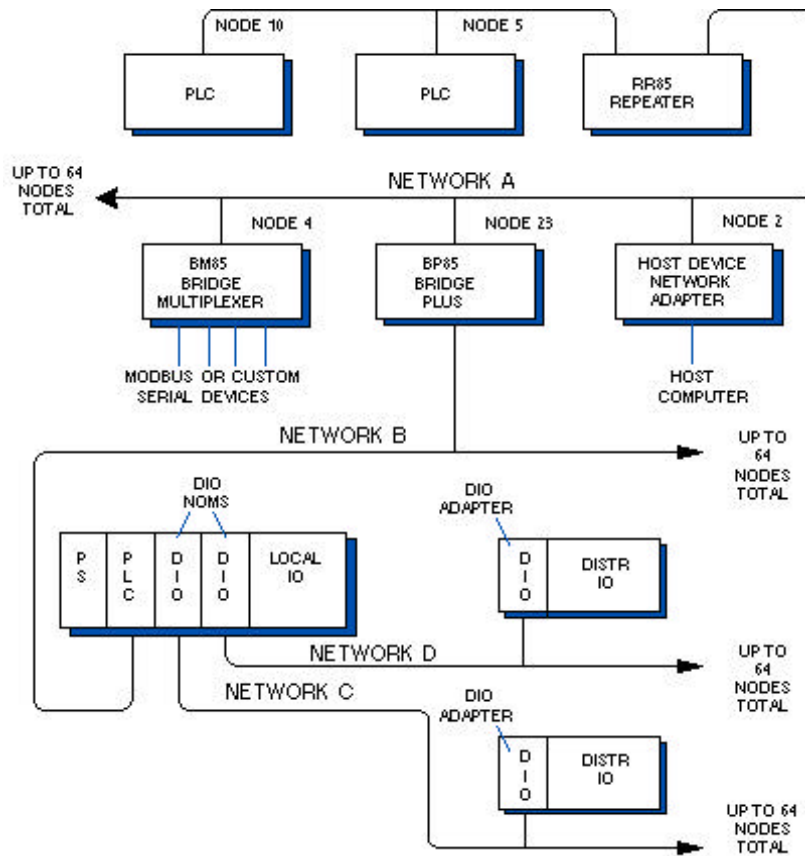

TOKEN ROTATION TIME

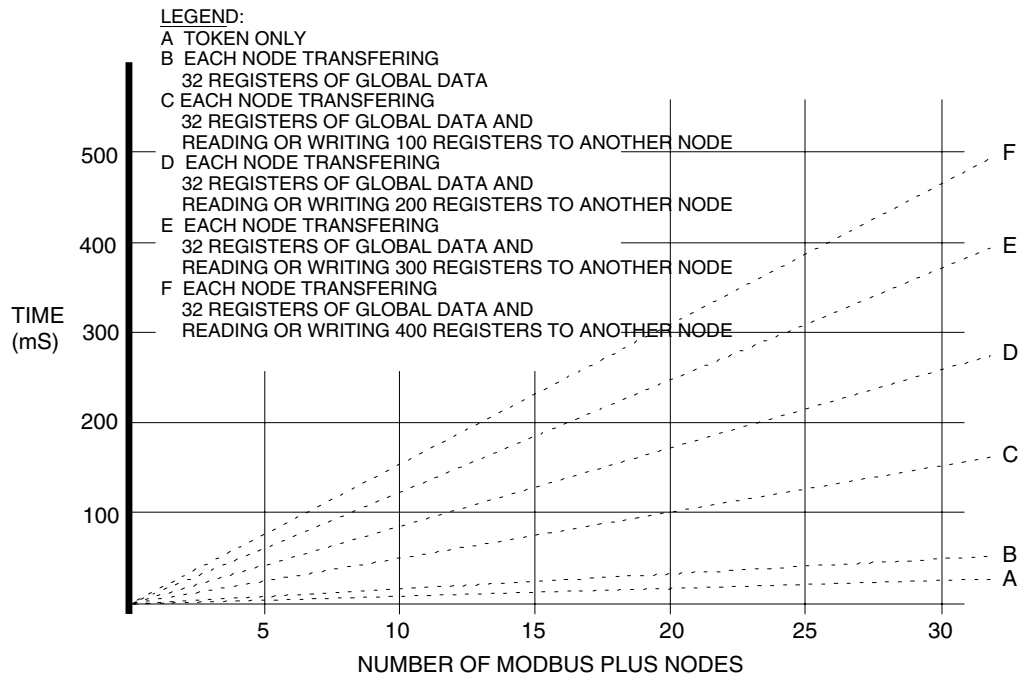

6. SOPC-G11S-MBP OVERVIEW

These sections contain all necessary information to start-up and use the SOPC-G11S-MBP option card.

6.1 PHYSICAL INTERFACE

Isolation: The bus signals are isolated from the network via a transformer.

Bus connection: The SOPC-G11S-MBP option card connects to the Modbus Plus network with a 9-pin female DSUB connector. For the pin layout, refer to the table below.

Pin	Name	Function
Housing	PE	Connected to PE
1	Shield	Connected to shield
2	B-Line	Positive RxD/TxD according to RS 485 specification
3	A-Line	Negative RxD/TxD according to RS 485 specification
4	Not Connected	-
5	Not Connected	-
6	Not Connected	-
7	Not Connected	-
8	Not Connected	-
9	Not Connected	-

6.2 CONFIGURATION

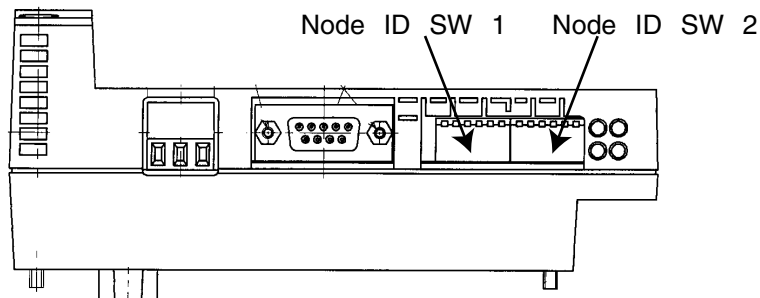

6.2.1 Node ID Switch 1

The Node ID on the Modbus Plus node is set before power on. Any change of Node ID during power on is not valid until next power cycle. The address is set in binary format.

1 MSB	2	3	4	5	6 LSB	Function
ON	ON	ON	ON	ON	ON	Node address set to 1
ON	ON	ON	ON	ON	OFF	Node address set to 2
ON	ON	ON	ON	OFF	ON	Node address set to 3
-	-	-	-	-	-	
OFF	OFF	OFF	OFF	OFF	ON	Node address set to 63
OFF	OFF	OFF	OFF	OFF	OFF	Node address set to 64

PLEASE NOTE: The node address cannot be changed during operation.

6.2.2 Source ID Switch 2

The SOPC-G11S-MBP uses one node address from 1 -64 to configure what node it will extract the global data from, sent during the token pass. The amount of extracted data is set by the o31-parameter, which will be described later.

The address is set in binary format.

1 MSB	2	3	4	5	6 LSB	Function
ON	ON	ON	ON	ON	ON	Node address set to 1
ON	ON	ON	ON	ON	OFF	Node address set to 2
ON	ON	ON	ON	OFF	ON	Node address set to 3
-	-	-	-	-	-	
OFF	OFF	OFF	OFF	OFF	ON	Node address set to 63
OFF	OFF	OFF	OFF	OFF	OFF	Node address set to 64

PLEASE NOTE: The source address cannot be changed during operation.

6.2.3 Changeover of communications

In order to enable the inverter control through the communication (by command data and operation data), the inverter function code "H30: Serial link (Function selection)" should be configured for a value of 1-3. The reading and writing of function data and functions are possible at any time regardless of the setting of Function code H30.

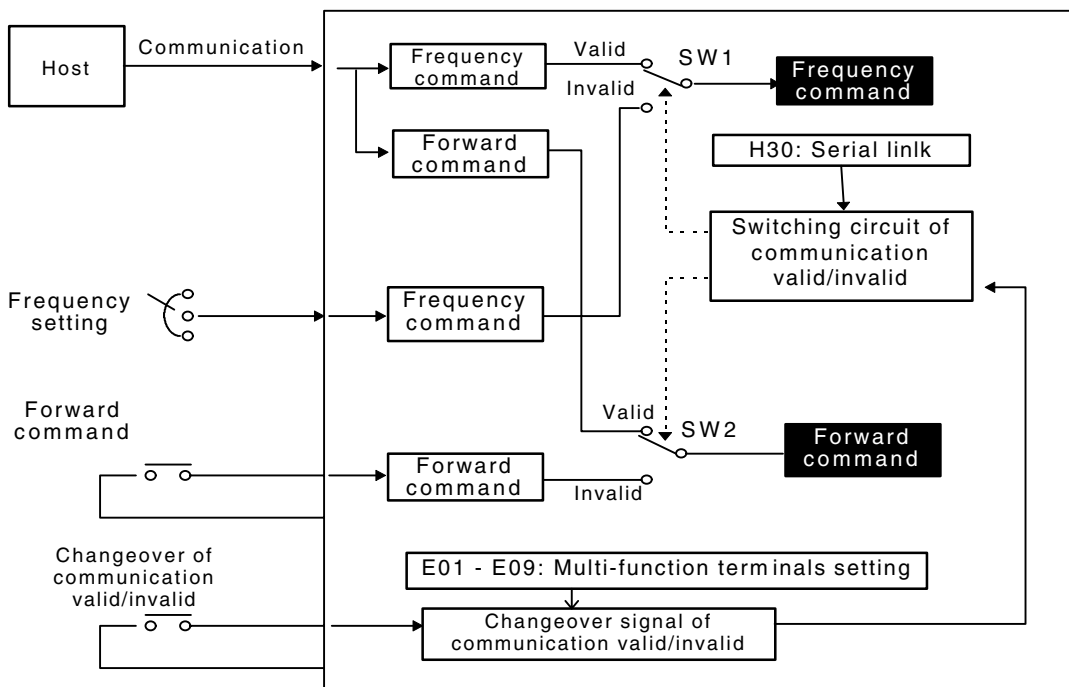

6.2.3.1 Changeover method for communication control

The changeover of the communication control can be performed by the multi-function command terminals (terminals X1-X9) on the inverter. However, it is necessary to configure the inverter's multi-function command input terminals (E01 - E09: X1-X9 terminals function) to the link operation selection (Data 24). If the multi-function command terminals have not been set to the link operation selection, the communication becomes valid automatically.

Input terminals	State
OFF	Communication invalid mode
ON	Communication valid mode (H30 setting)

Note:

- 1) Since all memories are initialized at switching power supply on, the command data and operation data must be write again from the upstream units.
- 2) Even when the communication is invalid, the writing of command data and operation data is valid, but it is not reflected by SW1 o SW2. The changeover without shock is possible by the way the data is set prior to the transition.

6.2.3.2 Link function configuration (operation selection)

The setting (valid/invalid) for command data and operation data during the communication valid period is possible individually by the setting of "H30: Serial link (Function selection)". (By making the communication always valid without setting at the multi-function terminals, changeover for the H30 data valid/invalid can change over the communication valid/invalid, similar to the changeover with multi-function command terminals.)

Link function H30	During communication is valid		During communication is invalid
	SW1 (Command data)	SW2 (Operation data)	SW1, SW2
0	Invalid	Invalid	Invalid
1	Valid	Invalid	
2	Invalid	Valid	
3	Valid	Valid	

6.2.3.3 Coexistence of link (option) and RS485 (or Modbus RTU) communication

When the link options (such as T link, field bus, etc.) are mounted on the inverter, the communication is positioned as described below and the functions are restricted.

Link: The operation through the fieldbus (either one of command data and operation data or both), the operation monitoring, and the reading and changing of functions are possible.

RS485: The operation monitoring and the reading and changing of inverter configuration functions codes is possible (Operation through the RS485 communication is impossible).

Note:

- 1) The communication valid bit of M14: Operating state becomes the state signal of link option and not of RS485.
- 2) When the command data and operation data are accessed from RS485, NAK is returned.
- 3) If the writing of functions is performed through this communication during the writing of functions by the link, NAK (no writing right error) is returned.

6.2.4 DATA MAP I/O CONFIG

The SOPC-G11S-MBP option card supports Global Data Base transfer.

Each Modbus Plus node can (if this functionality is supported) send up to 32 words of global data while transferring the token. Each Modbus Plus node can extract this global data and build a global database of all active Modbus Plus nodes global data.

SOPC-G11S-MBP option card supports a maximum I/O size of: 8 words INPUT data (PLC -> Drive) / 12 words OUTPUT data (Drive -> PLC).

SOPC-G11S-MBP option card uses up to 23 o-parameters, 3 for configuration and 20 for I/O data mapping.

o-parameter	Description
o30	Global Data Input Offset , offset within the Global Data Base
o31	Number of Global Data Inputs words
o32	Number of Global Data words producing
o33– o52	o-parameters for I/O data mapping. (Set from keypad, fieldbus)

Note: The SOPC-G11-MPB Software Rev.1.01 has a known bug:

When using the I/O data map for controlling the inverter no parameter write to the same parameter as in the I/O data map should be executed; this might cause that this parameter is not update after a parameter write until new data is sent on the I/O data.

6.2.5 Global Data Input Offset, Parameter o30

PLC -> Drive (R/W)

This global data base feature is used in the SOPC-G11S-MBP option card to extract global data from one specific node. That node's ID is set with the **Source ID switch**. The start Offset within this specified source node database is set by parameter o30.

o30 data	Selection
0	Starts from first global data word
1	Starts from second global data word
2	Starts from third global data word
...	
...	
30	Starts from the thirtieth global data word
31	Starts from the thirtyfirst global data word

The o30 parameter is connected to parameter o31 in that way that the maximum value of o30 is depending on o31.

After this parameter has been changed the drive has to be re-powered for the change to take effect.

6.2.6 Number of Global Data Inputs words, Parameter o31

PLC -> Drive (R/W)

The amount of words extracted from the chosen Source Node is set with parameter o31.

o31 data	Selection	o-parameters used
0	0 global data words is extracted.	None
1	1 global data word is extracted.	o37
2	2 global data words are extracted.	o37, o38
3	3 global data words are extracted.	o37, o38, o39
4	4 global data words are extracted.	o37, o38, o39, o40
5	5 global data words are extracted.	o37, o38, o39, o40, o49
6	6 global data words are extracted.	o37, o38, o39, o40, o49, o50
7	7 global data words are extracted.	o37, o38, o39, o40, o49, o50, o51
8	8 global data words are extracted.	o37, o38, o39, o40, o49, o50, o51, o52

After this parameter has been changed the drive has to be re-powered for the change to take affect.

6.2.7 Number of Global Data words producing, Parameter o32

Drive -> PLC

The SOPC-G11S-MBP option card sends global data while the token passes. This data is used as I/O OUT data from the SOPC-G11S-MBP option card. All Modbus Plus nodes on the network will extract this data from the token pass and build its own global database.

o32 data	Selection	o-parameters used
0	0 global data word is sent.	None
1	1 global data word is sent.	o33
2	2 global data words are sent.	o33, o34
3	3 global data words are sent.	o33, o34, o35
4	4 global data words are sent.	o33, o34, o35, o36
5	5 global data words are sent.	o33, o34, o35, o36, o41
6	6 global data words are sent.	o33, o34, o35, o36, o41, o42
7	7 global data words are sent.	o33, o34, o35, o36, o41, o42, o43
8	8 global data words are sent.	o33, o34, o35, o36, o41, o42, o43, o44
9	9 global data words are sent.	o33, o34, o35, o36, o41, o42, o43, o44, o45
10	10 global data words are sent.	o33, o34, o35, o36, o41, o42, o43, o44, o45, o46
11	11 global data words are sent.	o33, o34, o35, o36, o41, o42, o43, o44, o45, o46, o47
12	12 global data words are sent.	o33, o34, o35, o36, o41, o42, o43, o44, o45, o46, o47, o48

6.2.8 Configuration of Global Data / Data Map I/O

Assigning parameters to Global Data word 1-8 (PLC -> Drive) and 1 -12 (Drive -> PLC) can be performed in two ways:

1. From keypad (o33-o36, o41- o48) and (o37-o40, o49-o52)
2. From network (Point-to-point Modbus commands) *.

After changing these parameters the drive has to be re-powered for the change to take affect.

* If the safety register is disabled.

Assignment from keypad:

Assignment of Global Data Base write word 1-8(PLC -> Drive)

o37 = Communication number for parameter transferred in GDB, word 1 from Source ID X.

o38 = Communication number for parameter transferred in GDB, word 2 from Source ID X.

o39 = Communication number for parameter transferred in GDB, word 3 from Source ID X.

o40 = Communication number for parameter transferred in GDB, word 4 from Source ID X.

o49 = Communication number for parameter transferred in GDB, word 5 from Source ID X.

o50 = Communication number for parameter transferred in GDB, word 6 from Source ID X

o51 = Communication number for parameter transferred in GDB, word 7 from Source ID X

o52 = Communication number for parameter transferred in GDB, word 8 from Source ID X.

Assignment of Global Data Base read word 1-12(Drive ->PLC)

o33 = Communication number for parameter transferred in GDB, word 1 from the SOPC-G11S-MBP.

o34 = Communication number for parameter transferred in GDB, word 2 from the SOPC-G11S-MBP.

o35 = Communication number for parameter transferred in GDB, word 3 from the SOPC-G11S-MBP.

o36 = Communication number for parameter transferred in GDB, word 4 from the SOPC-G11S-MBP.

o41 = Communication number for parameter transferred in GDB, word 5 from the SOPC-G11S-MBP.

o42 = Communication number for parameter transferred in GDB, word 6 from the SOPC-G11S-MBP.

o43 = Communication number for parameter transferred in GDB, word 7 from the SOPC-G11S-MBP.

o44 = Communication number for parameter transferred in GDB, word 8 from the SOPC-G11S-MBP.

o45 = Communication number for parameter transferred in GDB, word 9 from the SOPC-G11S-MBP.

o46 = Communication number for parameter transferred in GDB, word 10 from the SOPC-G11S-MBP.

o47 = Communication number for parameter transferred in GDB, word 11 from the SOPC-G11S-MBP.

o48 = Communication number for parameter transferred in GDB, word 12 from the SOPC-G11S-MBP.

Example:

To map the first word IN to the drive to Operation Command (S06); set o37 to the value 6 (decimal).

Please see section 7.9 Parameter data format for more information.

Assignment from network:

This can be done with a point-to-point Modbus message using the 984 PLC MSTR commands write or the SA85 card utilizing the NetBIOS send commands.

Assignment of Global Data Base write word 1-8 (PLC -> Drive) with parameter configuration write

- o37 (parameter 236) = Comm. No for parameter transferred in GDB, word 1 from Source ID X.
- o38 (parameter 237) = Comm. No for parameter transferred in GDB, word 2 from Source ID X.
- o39 (parameter 238) = Comm. No for parameter transferred in GDB, word 3 from Source ID X.
- o40 (parameter 239) = Comm. No for parameter transferred in GDB, word 4 from Source ID X.
- o49 (parameter 248) = Comm. No for parameter transferred in GDB, word 5 from Source ID X.
- o50 (parameter 249) = Comm. No for parameter transferred in GDB, word 6 from Source ID X.
- o51 (parameter 250) = Comm. No for parameter transferred in GDB, word 7 from Source ID X.
- o52 (parameter 251) = Comm. No for parameter transferred in GDB, word 8 from Source ID X.

Assignment of Global Data Base read word 1-12(Drive ->PLC) with parameter configuration write

- o33 (parameter 232) = Comm. No for parameter transferred in GDB, word 1 from the SOPC-G11S-MBP.
- o34 (parameter 233) = Comm. No for parameter transferred in GDB, word 2 from the SOPC-G11S-MBP.
- o35 (parameter 234) = Comm. No for parameter transferred in GDB, word 3 from the SOPC-G11S-MBP.
- o36 (parameter 235) = Comm. No for parameter transferred in GDB, word 4 from the SOPC-G11S-MBP.
- o41 (parameter 240) = Comm. No for parameter transferred in GDB, word 5 from the SOPC-G11S-MBP.
- o42 (parameter 241) = Comm. No for parameter transferred in GDB, word 6 from the SOPC-G11S-MBP.
- o43 (parameter 242) = Comm. No for parameter transferred in GDB, word 7 from the SOPC-G11S-MBP.
- o44 (parameter 243) = Comm. No for parameter transferred in GDB, word 8 from the SOPC-G11S-MBP.
- o45 (parameter 244) = Comm. No for parameter transferred in GDB, word 9 from the SOPC-G11S-MBP.
- o46 (parameter 245) = Comm. No for parameter transferred in GDB, word 10 from the SOPC-G11S-MBP.
- o47 (parameter 246) = Comm. No for parameter transferred in GDB, word 11 from the SOPC-G11S-MBP.
- o48 (parameter 247) = Comm. No for parameter transferred in GDB, word 12 from the SOPC-G11S-MBP.

Please Note

1. Data map I/O words (o41 -o48 and o49-o52) are only available if no SY-option is enabled and the drive is stopped.
2. Communication numbers are within the range 1-255. If a communication number = 0, this certain Global Data Base word will be ignored by SOPC-G11S-MBP.
3. If there is no communication number associated to o41-o52 these will not be us on the Modbus Plus Network.

6.2.9 Safety Register

The SOPC-G11S-MBP option card has an internal safety register to be able to lock out any parameter write to the o-parameters that controls the Data Map I/O configurations (o30 -o52). This register is stored in Non Volatile memory. By default is this register set to DISABLED.

Register 300	Data	Description
DISABLED	0x875A (34650 dec)	This will allow o30 to o52 to be written from the bus
ENABLED	0xA578 (42360 dec)	No writing to o30 to o52 is allowed.

Example:

The following example will display how to enable the safety register with a MSTR block WRITE function:

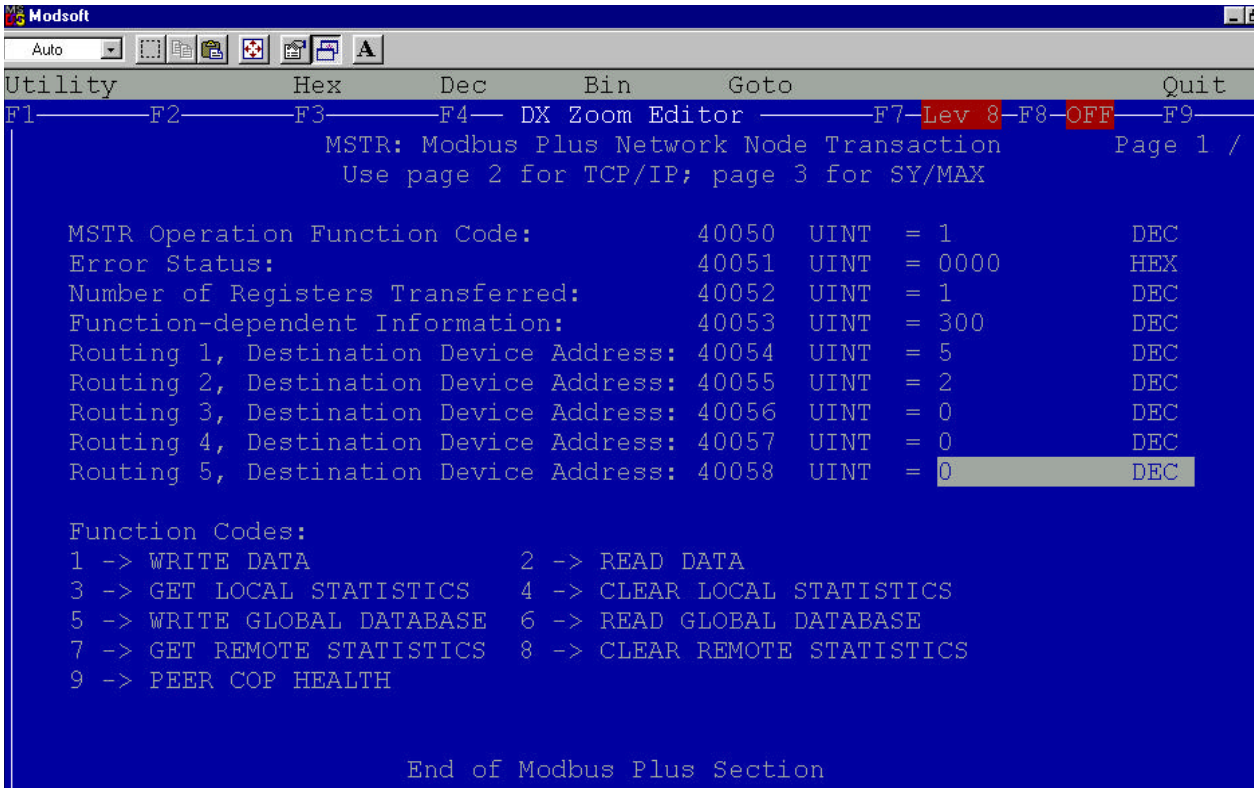

```

Modsoft
Auto
Utility      Hex      Dec      Bin      Goto      Quit
F1-----F2-----F3-----F4--- DX Zoom Editor -----F7- Lev 8 -F8-OFF-----F9-
MSTR: Modbus Plus Network Node Transaction      Page 1 / 3
Use page 2 for TCP/IP; page 3 for SY/MAX

MSTR Operation Function Code:      40050  UINT  = 1      DEC
Error Status:                      40051  UINT  = 0000   HEX
Number of Registers Transferred:    40052  UINT  = 1      DEC
Function-dependent Information:     40053  UINT  = 300   DEC
Routing 1, Destination Device Address: 40054  UINT  = 5      DEC
Routing 2, Destination Device Address: 40055  UINT  = 2      DEC
Routing 3, Destination Device Address: 40056  UINT  = 0      DEC
Routing 4, Destination Device Address: 40057  UINT  = 0      DEC
Routing 5, Destination Device Address: 40058  UINT  = 0      DEC

Function Codes:
1 -> WRITE DATA      2 -> READ DATA
3 -> GET LOCAL STATISTICS  4 -> CLEAR LOCAL STATISTICS
5 -> WRITE GLOBAL DATABASE 6 -> READ GLOBAL DATABASE
7 -> GET REMOTE STATISTICS 8 -> CLEAR REMOTE STATISTICS
9 -> PEER COP HEALTH

End of Modbus Plus Section
    
```

Then you need to set the corresponding data in MSTR output word.

6.3 ACTION AT COMMUNICATION ERROR

In case of occurring transmission errors (communication cutoff with the master), the following actions can be selected.

1) Select action when error is detected. (o27)

o27	Action at error detection		Remarks
0	Immediate forced stop	Er5	
1	Continue operation within o28 time and stop	Er5	Continue operation using the command just before the error within o28 time, but when restoring, operate following to the designation of communication.
2	Continue operation according to the last command received until restoration of the communication. If the communication is not restored before the o28 time expires, then immediate forced stop.	Er5	
3	Continue operation till restoration of the communication, and after the restoration, follow to designation of communication.	Automatic restoration after restoring communication	

2) Setting time of timer at error (o28)

0.0 - 60.0s

In a case of o27=0 (Mode of immediate forced stop at communication error detection)

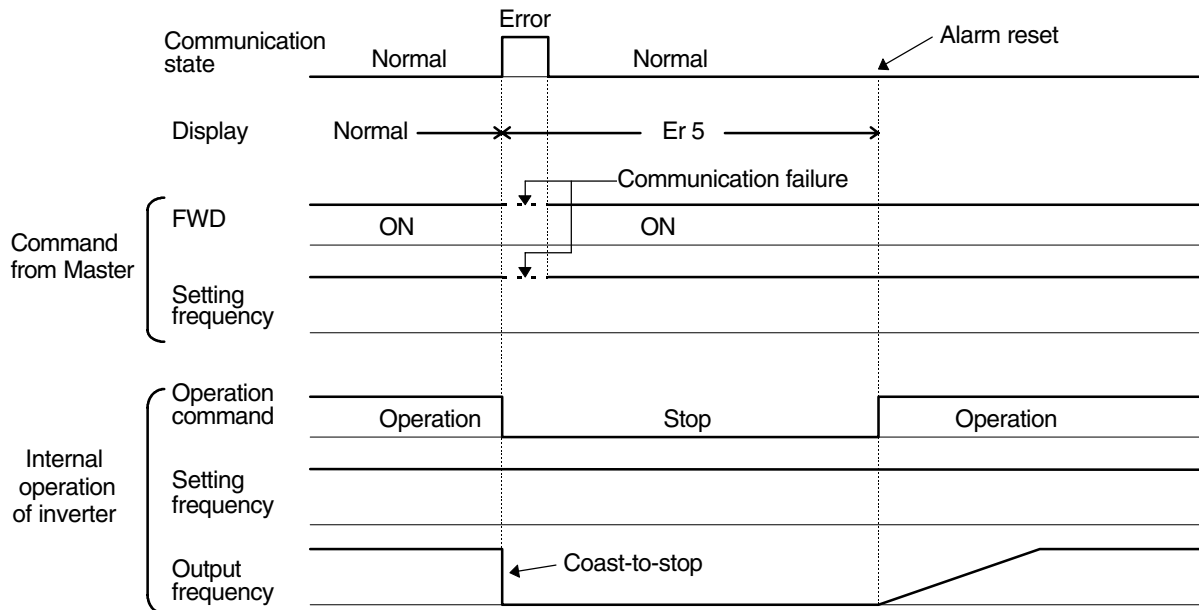

In a case of o27=1, o28=5.0 s (Mode of immediate forced stop after 5 s at occurring communication error)

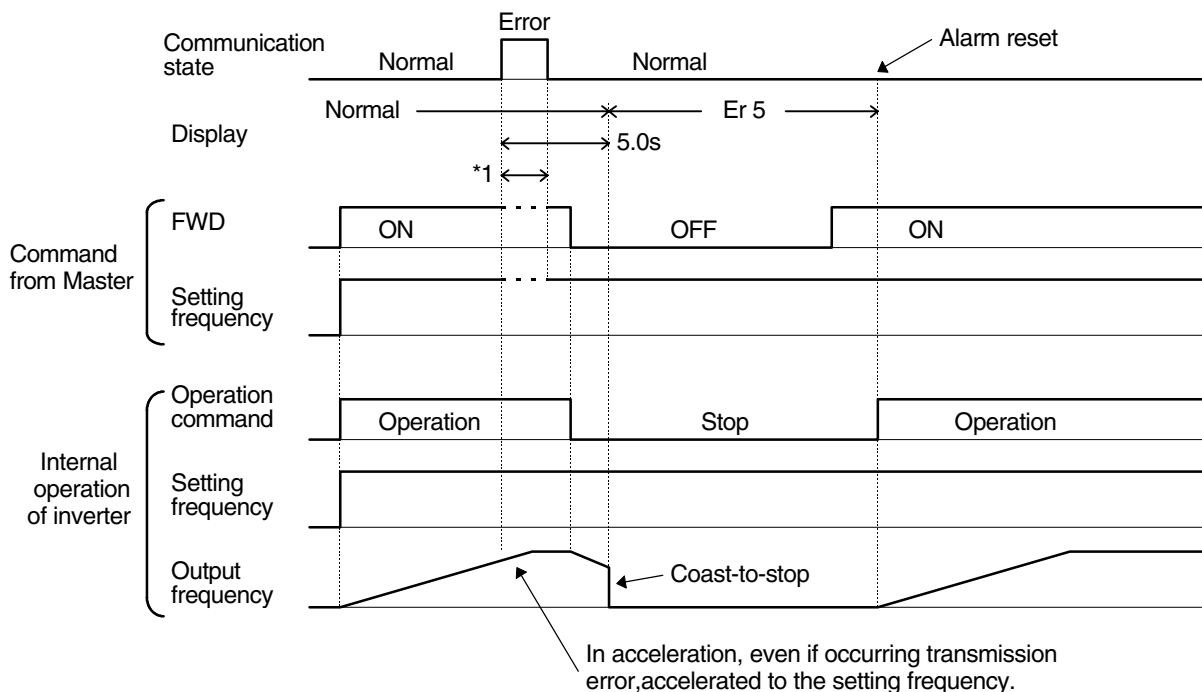

*1) In a period until restoring the communication, the last commands (command data and operation data) received before the error are kept.

In a case of o27=2, o28=5.0 s (The communication is not restored for 5.0 sec after error detection, and inverter trips Er5.)

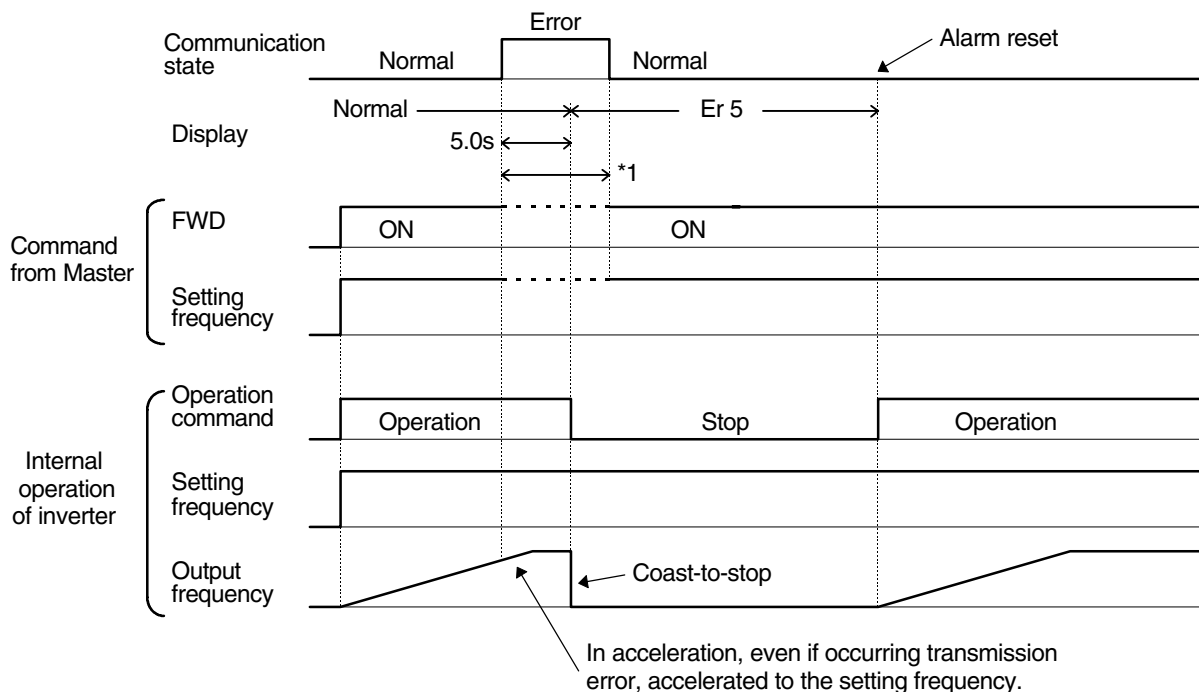

In a case of o27=2, o28=5.0 s (A communication error occurs, but restored within 5 s.)

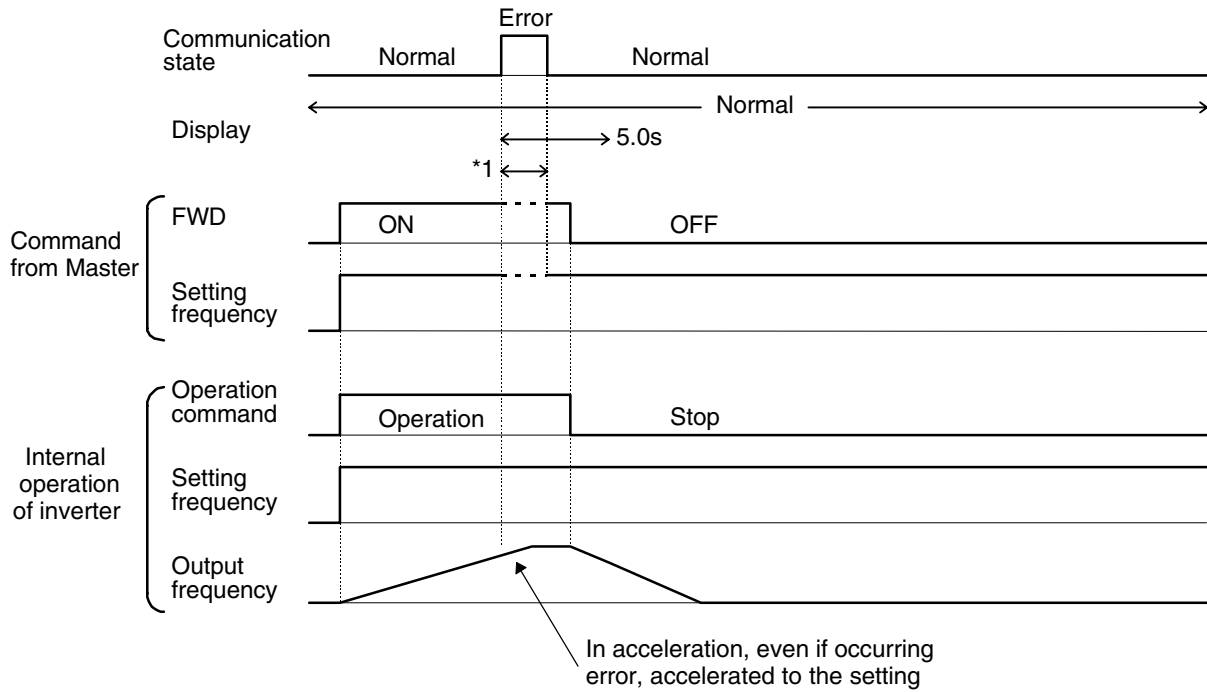

*1) In a period until restoring the communication, the commands (command data and operation data) just before the error are kept.

In a case of o27=3 (When a communication error occurs, the operation continues)

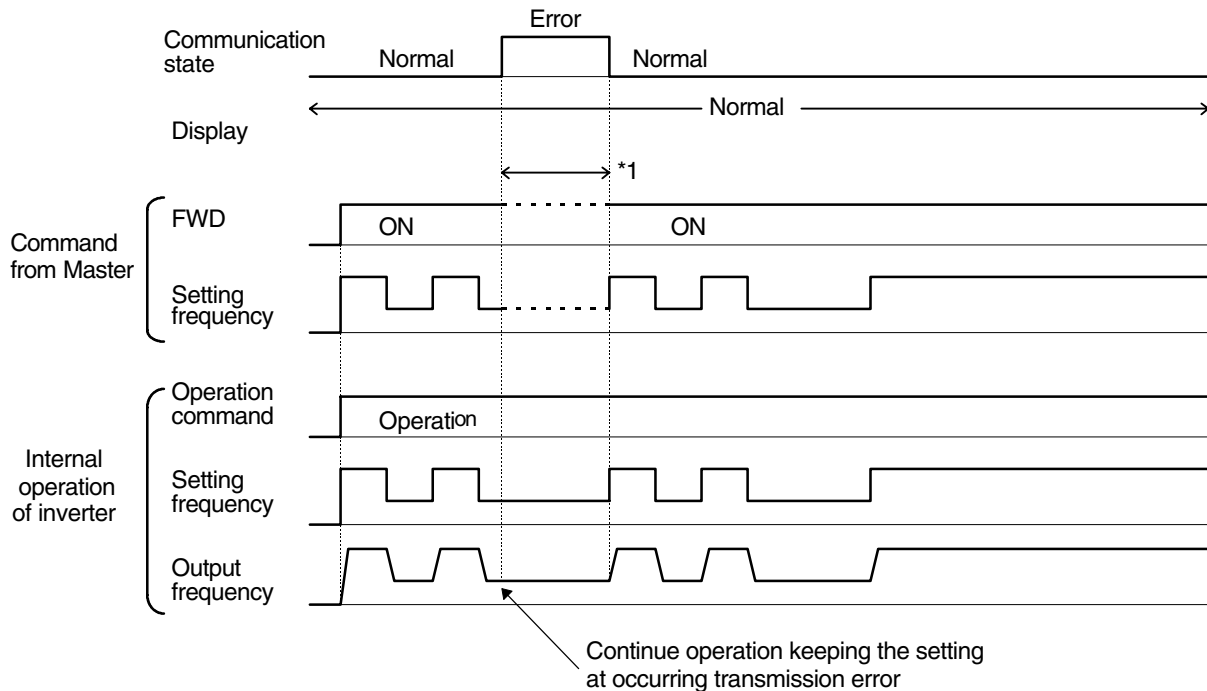

6.4 INDICATION LED'S

The module is equipped with four LED's mounted at the front and one LED on the board, used for debugging purposes. The functions of the LED's are described in the table and figure below.

- 1. Not used
- 2. Modbus Plus Error
- 3. Modbus Plus diagnostic LED
- 4. Not used

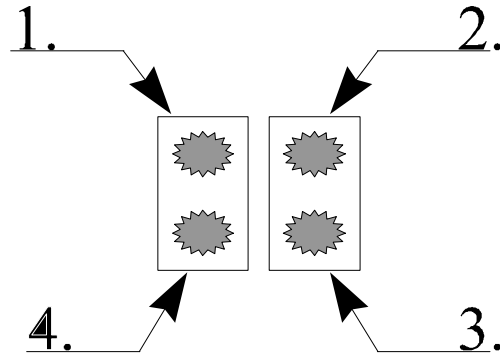

Figure 5. LED's,

LED No	Color	Function
1.	-	Not used
2. Error	Red	Indicating no bus communication, solid state
3. Diagnostic LED	Green	Indicating different Node Status: flash every 160 mS This node works normal, receiving and passing token. flash every 1 Sec. This node is in MONITOR_OFFLINE state. 2 flashes, off 2 Sec. This node is in MAC_IDLE nevergetting-token state. 3 flashes, off 1,7 Sec. This node is not hearing any other nodes. 4 flashed, off 1,4 Sec. This node have heard a valid packet that has a duplicated node address sent from another node on the network, using the same Node ID.
4.	-	Not used

7. OPERATING THE DRIVE VIA MODBUS PLUS

This section describes how to control the drive via control word/status word and how to access drive parameters.

7.1 GLOBAL DATA (I/O DATA MAP)

The control/status data is transferred by the Global Data, which can be used as the following table example describes.

Drive Bus Configuration Paramete	Description
CfgPar o32	Number of Global Data words producing
CfgPar o33	FunctionCode for Global Data word 1
CfgPar o34	FunctionCode for Global Data word 2
CfgPar o35	FunctionCode for Global Data word 3
CfgPar o36	FunctionCode for Global Data word 4
CfgPar o41	FunctionCode for Global Data word 5
CfgPar o42	FunctionCode for Global Data word 6
CfgPar o43	FunctionCode for Global Data word 7
CfgPar o44	FunctionCode for Global Data word 8
CfgPar o45	FunctionCode for Global Data word 9
CfgPar o46	FunctionCode for Global Data word 10
CfgPar o47	FunctionCode for Global Data word 11
CfgPar o48	FunctionCode for Global Data word 12
CfgPar o30	Global Data Input Offset
CfgPar o31	Number of Global Data Input words
CfgPar o37	Global data command 1
CfgPar o38	Global data command 2
CfgPar o39	Global data command 3
CfgPar o40	Global data command 4
CfgPar o49	Global data command 5
CfgPar o50	Global data command 6
CfgPar o51	Global data command 7
CfgPar o52	Global data command 8

This function is supported in Modicon 984 PLC.

Can be accessed by using a MSTR block with the (OP Code = 5) WRITE GLOBAL DATABASE and (OP Code =6) READ GLOBAL DATABASE.

This function is supported in Modicon SA85 card.

The NetLIB functions ncb_send_datagram() and ncb_receive_datagram() can be used.

7.2 EXAMPLE

Parameter	Description	Example parameter settings
o32	Number of Global Data words producing	12 words
o33	FunctionCode for Global Data word 1	M14 Operating State
o34	FunctionCode for Global Data word 2	M06 Actual Frequency
o35	FunctionCode for Global Data word 3	M07 Actual Torque
o36	FunctionCode for Global Data word 4	M08 Torque Current
o41	FunctionCode for Global Data word 5	M11 Output Current rms
o42	FunctionCode for Global Data word 6	M12 Output Voltage
o43	FunctionCode for Global Data word 7	M15 Universal Output
o44	FunctionCode for Global Data word 8	M16 Fault Memory
o45	FunctionCode for Global Data word 9	M13 Operation Command
o46	FunctionCode for Global Data word 10	M01 Frequency Command
o47	FunctionCode for Global Data word 11	M17 1* Previous Fault
o48	FunctionCode for Global Data word 12	M18 2* Previous Fault
o30	Global Data Input Offset	0 words in offset
o31	Number of Global Data Input words	4 words
o37	Global data command 1	S06 OperatiorCommand
o38	Global data command 2	S05 Frequency Command (Hz)
o39	Global data command 3	S07 Universal Do
o40	Global data command 4	S12 Universal Ao
o49	Global data command 5	0
o50	Global data command 6	0
o51	Global data command 7	0
o52	Global datacommand 8	0

7.3 EXAMPLE

This example will display how to configure a MSTR block, for writing the Operation Command (S06) witch is mapped to the o-parameter 37(dec) (the first global data IN word), and o30 is set to 0=zero offset.

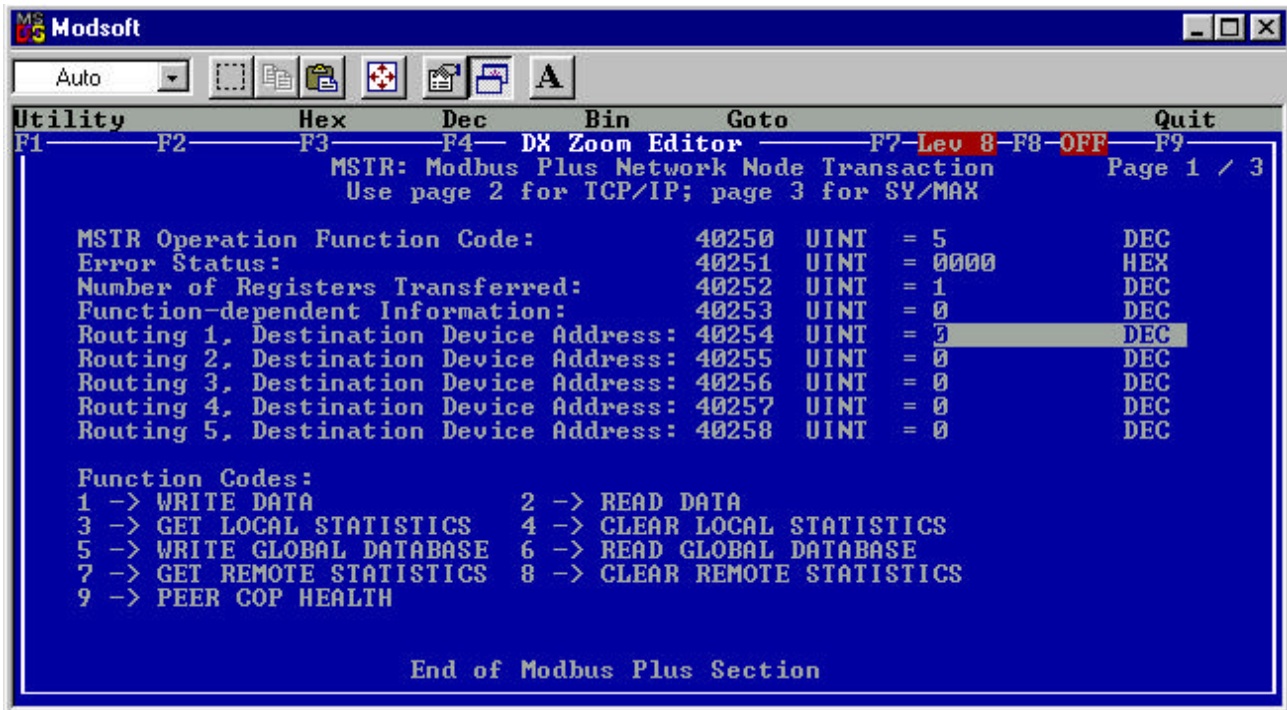

Then you need to set the corresponding data in MSTR output word.

7.4 PARAMETER READ/WRITE

The infrequent parameter transfer can use the Point-to-point communication, such as Acceleration and Deceleration.

Communication numbers are within the range 1-255. Please see section 7.9 Parameter data format for more information.

If a communication number = 0, this request will return an exception response to the request. Please see next chapter for more details.

Following (Point-to-point data = Parameter data) commands are supported in SOPC-G11S-MBP option card:

Read Holding Registers (Function 0x03).

Preset Multiple Registers (Function 0x10).

Preset Single Register (Function 0x06).

7.4.1 Exception responses

Exception Code	Error condition
0x01	Illegal function for the addressed slave
0x02	Illegal data address within the information field for the addressed slave
0x03	Illegal data value within the information field for the addressed slave
0x06	Busy the function just requested cannot be performed at this time

Note : The notation 0x01 is Hexadecimal notation.

Exception Code 0x01

- If requesting a Point-to-point service not supported by the SOPC-G11S-MBP option card this exception response will be returned to the node that requested the service.

Exception Code 0x02

- When addressing a register not within the index 1- 255 or 300, exception code 0x02 is returned to the node that requested this service.

Exception Code 0x03

- When writing to a read only register exception code 0x03 is returned to the node that requested this service.
- When the requested register is out of range exception code 0x03 is returned to the node that requested this service.
- When the requested register is not changeable due to the drive is running.

Exception Code 0x06

- When the inverter indicates that it is busy; exception code 0x06 is returned to the node that requested this service.
- When a "Link priority error", "State conflict error", "Communication error" or "Other communication error" has occurred; exception code 0x06 is returned to the node that requested this service

7.4.2 Point-to-point parameter usage

Non-frequent and non-cyclic parameters should use the Point-to-point Modbus commands supported by the SOPC-G11S-MBP option card.

Following (Point-to-point data = Parameter data) commands are supported:

Read Holding Registers (Function 0x03).

Preset Multiple Registers (Function 0x10).

Preset Single Register (Function 0x06).

Note: All these Modbus functions are 4xxxx -register commands (16 bit).

7.4.3 Setting the Routing Path

When Point-to-point Modbus commands are used it is important to specify the correct Routing Path to the requested node.

Only Slave Data Paths is supported in SOPC-G11S-MBP option card. This means that the SOPC-G11S-MBP option card only can respond to incoming requests. These 8 Slave Data Paths is implemented as a queue system, were path 1 is handled first and the others then in an incremented way.

To write to node 5 within the same network (no bridging to another network), the five digits Routing Path should be:

5. 2. 0. 0. 0.

5 = Node ID.

2 = Slave Data Path. 1 to 8.

7.4.4 Read Holding Registers

This function is supported in Modicon 984 PLC.

Can be accessed by using a MSTR block with the (OP Code = 2) READ DATA.

If using a SA85 card from Modicon, NetLIB functions can be used.

7.4.5 Preset Multiple Registers

This function is supported in Modicon 984 PLC.

Can be accessed by using a MSTR block with the (OP Code = 1) WRITE DATA.

This function is supported in Modicon SA85 card.

The NetLIB functions can be used.

7.4.6 Preset Single Register

This functionality is not supported in Modicon 984 PLC.

This function is supported in Modicon SA85 card.

The NetLIB functions can be used.

7.4.7 Example

This example will display how to configure the MSTR block, for READING the Operating state (M14) in node No 5 were it is mapped to the o-parameter 33, (1C hex) (the first global data OUT word).

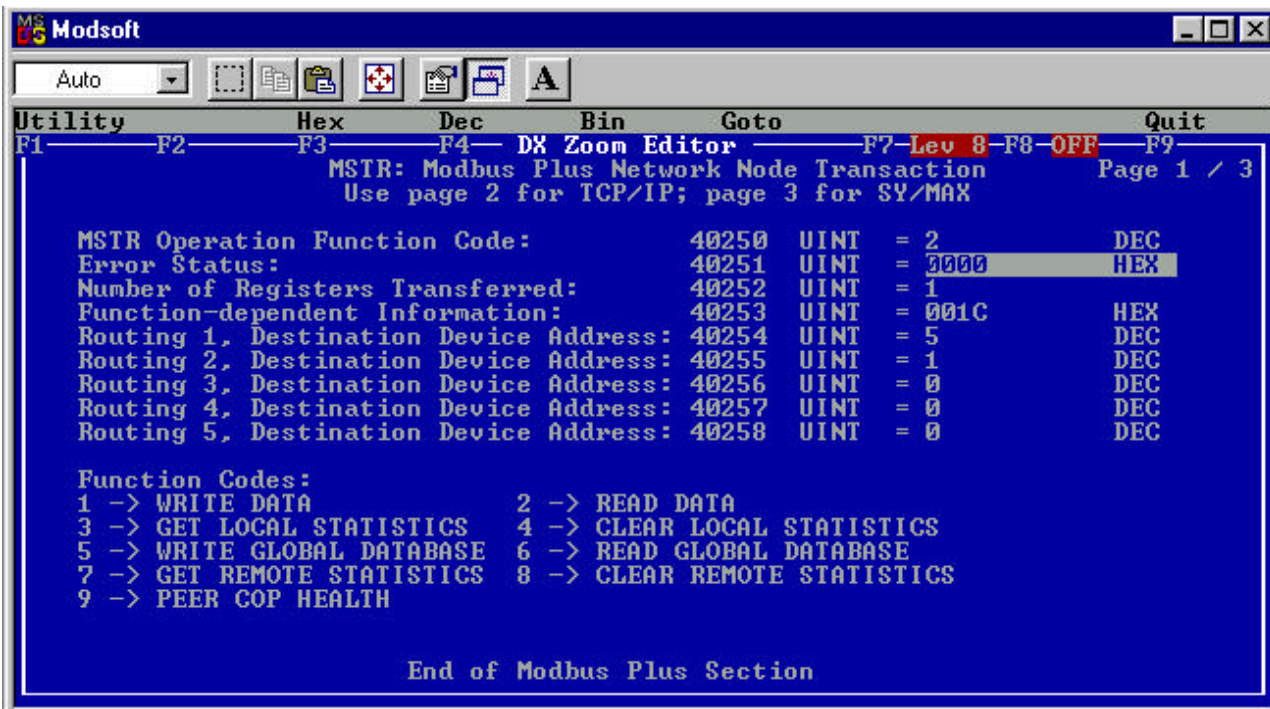

Then you need to monitor the corresponding data in MSTR input word.

7.4.8 Memorizing history of written parameters

The SOPC-G11S-MBP is memorizing the history of written parameters and if the parameters differ from the previous write operation it will be written down to the inverter, otherwise it will return a success code.

If changes are made to inverter parameters through the keypad while the fieldbus is running, there may be a difference between the last written parameter data to those parameters.

Example scenario:

1. The SOPC-G11S-MBP is running the inverter and updating some parameters by point-to-point parameter writes, e.g. parameter No 10 (S10 Torque limit level 1, Driving) is set by a PLC to 40(dec). If the next point-to-point parameter write to parameter 10 is the same, i.e. 40(dec) this will not be written down to the inverter, but the success code will be returned to the PLC.
2. The parameter S10 is then set to 70(dec) by the keypad. The SOPC-G11S-MBP is still running.
3. The SOPC-G11S-MBP is not detecting the change of parameter S10, and the parameter value 70(dec) will not be changed until the PLC is writing a new value separate to 40(dec) to parameter S10.
4. The inverter will use the S10 value of 70(dec) until next point-to-point parameter write to the S10 with a value other than 40 (dec) has occurred.

8. PARAMETERS SPECIFIC FOR COMMUNICATION

To operate the inverters or to monitor the state via communication, the following parameters are available for communication in addition to the configuration functions of the inverters. These parameters are a common data format applicable to inverter types on and after GP10 / VG10 series, so that it is possible to access different inverter types by the same program on the host side.

8.1 COMMAND DATA

Code	Name	Unit	Variable range	Min. unit	Read/write
S01	Setting frequency (p.u.)	-	-20000 – 20000 (Maximum frequency at \pm 20000)	1	R
S05	Setting frequency	Hz	0.00–400.00 (P11S:0.00–120.00)	0.01	R

Note:

- 1) The data writing exceeding the setting range is possible, but the actual action will be restricted within the inverter.
- 2) When the command data is read, it is not the command data of actual action but the command data communicated before (the final command data can be obtained by reading of the monitoring data described later).

8.2 OPERATION COMMAND DATA

Code	Name	Unit	Variable range	Min. unit	Read/write
S06	Operation command	-	Refer to the data format [11]	-	R/W
S07	Universal Do	-	Refer to the data format [12]	-	R/W
S12	Universal Ao	-	-20000–20000 (100% output at 20000)	1	R/W

Note:

- 1) Since X1-X9 are multi-function inputs, it is necessary to set the functions with E01-E09.
- 2) The alarm reset is executed, when RST signal changes from ON to OFF even there are no alarming factors.
- 3) Universal Do is a function utilizing inverter's Do via transmission.
(In detail, refer to the detail descriptions E20-E24 in "Function Explanation" in the instruction manual of inverter).
- 4) The data writing exceeding the setting range is possible, but the actual action will be restricted within the inverter.
- 5) When the operation commands are instructed through the communication, the relation to the inverter terminal commands becomes as follows.

Function			Command		
Classification	Symbol	Name	Transmission	Terminal block	
Operation command	FWD/REV	FWD/REV command	Valid	Invalid	
Multi-function command	0-3	SS1, 2, 4, 8			Valid
	4, 5	RT1, RT2	Invalid	Invalid	
	6	HLD			Invalid
	7	BX	Valid		
	8	RST	Valid		
	9	THR	Trip command (External fault)	Invalid	Valid
	10	JOG	Jogging operation	Invalid	
	11	Hz2/Hz1	Freq. set. 2 / Freq. set. 1	Valid	Invalid
	12	M2/M1	Motor 2 / Motor 1		
	13	DCBRK	DC brake command		
	14	TL2/TL1	Torque limiter 2 / Torque limiter 1		
	15, 16	SW50, SW60	Switching operation between line and inverter (50/60Hz)	Invalid	Valid
	17, 18	UP, DOWN	UP, DOWN command		
	19	WE-KP	Write enable for KEYPAD	Valid	Invalid
	20	Hz/PID	PID control cancel		
	21	IVS	Inverse mode changeover (terminals 12 and C1)		
	22	IL	Interlock signal for 522	Invalid	Valid
	23	Hz/TRQ	TRQ control cancel	Valid	Invalid
	24	LE	Link enable (Bus, RS485)	Invalid	Valid
	25	U-DI	Universal DI		
	26	STM	Pick up start mode	Valid	
	27	PG/Hz	SY-PG enable	Valid	Invalid
	28	SYC	Synchronization command		
	29	ZERO	Zero speed command		
	30	STOP1	Forced stop command	Invalid	Valid
	31	STOP2	Forced stop command with Deceleration time 4		
	32	EXITE	Pre-exciting command	Valid	

8.3 FUNCTION DATA

Code	Name	Unit	Variable range	Min. unit	Read/Write
S08	Acceleration time F07	s	0.1– 3600.0	0.1	R/W
S09	Deceleration time F08	s	0.1– 3600.0	0.1	R/W
S10	Torque limit level 1 (Driving) F40	%	20.00 – 200.00 (P11S : 20.00–150.00), 999	1.00	R/W
S11	Torque limit level 2 (Braking) F41	%	0.00, 20.00 – 200.00 (P11S : 20.00–150.00), 999	1.00	R/W

Note:

- 1) The writing to out of the range is treated as out of range error.
- 2) The acceleration and deceleration time S08 and S09 are assigned to "F07: Acceleration time,P" and "F08: Deceleration time 1" respectively.
- 3) The torque limit level 1 and 2 of S10 and S11 are assigned to "F40: Torque limit 1 (Driving)" and "F41: Torque limit 1 (Braking)" respectively.

8.4 MONITORING DATA

Code	Description	Unit	Range	Min. unit	Read/Write
M01	Setting frequency (Final data)	-	-20000–20000 (Maximum frequency at ±20000)	1	R
M05	Setting frequency (Final data)	Hz	0–400.00 (P11S: 0.00–120.00)	0.01	R
M06	Output frequency 1	-	-20000–20000 (Maximum frequency at ±20000)	1	R
M07	Torque calculation value	%	-200.00–200.00	0.01	R
M08	Torque current	%	-200.00–200.00	0.01	R
M09	Output frequency 1	Hz	0.00–400.00 (P11S:0.00–120.00)	0.01	R
M10	Input power	%	0.00–200.00	0.01	R
M11	Output current	%	0.00–200.00 (Inverter rating at 100.00)	0.01	R
M12	Output voltage	V	0.0–600.0	1.0	R
M13	Operation command (Final data)	-	Refer to the data format [11]	-	R
M14	Operating state	-	Refer to the data format [13]	-	R
M15	Y1-Y5 output terminal data	-	Refer to the data format [12]	-	R
M16	Fault memory 0	-	Refer to the Alarm code table below	-	R
M17	Fault memory (1st prior)	-			
M18	Fault memory (2nd prior)	-			
M19	Fault memory (3rd prior)	-			
M20	Operating time	h	0–65535	1	R
M21	DC link circuit voltage	V	0–1000	1	R
M23	Type code	-	Refer to the data format [14]	-	R
M24	Capacity code	-	Refer to the data format [9]	-	R
M25	ROM version	-	0–64999	1	R
M26	Transmission error code (RS 485)	-	Refer to the Alarm code table below	-	R
M27	Setting frequency at alarming (Final data)	-	-20000–20000 (Maximum frequency at 20000)	1	R
M31	Setting Frequency at alarming (Final data)	Hz	0–400.00 (P11S: 0.00–120.00)	0.01	R
M32	Output frequency at alarming	-	-20000–20000 (Maximum frequency at 20000)	1	R
M33	Torque calculation value at alarming	%	-200.00–200.00	0.01	R
M34	Torque current at alarming	%	-200.00–200.00	0.01	R
M35	Output frequency 1 at alarming	Hz	-400.00–400.00 (P11S:-120.00–120.00)	0.01	R
M36	Input power at alarming	%	0.00–200.00	0.01	R

M37	Output current at alarming	%	0.00-200.00 (Inverter rating at 100.00)	0.01	R
M38	Output voltage at alarming	V	0.0-600.0	1.0	R
M39	Operation command at alarming	-	Refer to the data format [11]	-	R
M40	Operating state at alarming	-	Refer to the data format [13]	-	R
M41	Y1-Y5 output terminal data at alarming	-	Refer to the data format [12]	-	R
M42	Operation time at alarming	h	0-65535	1	R
M43	DC link circuit voltage at alarming	V	0-1000	1	R
M44	Inverter internal air temp. at alarming	°C	0-120	1	R
M45	Cooling fin temp. at alarming	°C	0-120	1	R
M46	Life of main circuit capacitor	%	0.0-100.0	0.1	R
M47	Life of printed circuit board capacitor	h	0-65535	1	R
M48	Life of cooling fan	h	0-65535	1	R

Note :

- 1) The output frequency 1 is before slip compensation.
- 2) The output frequency 1 with speed regulator (using option SOPC-G11S-PG) is treated as the synchronous frequency.
- 3) Alarm code

Code	Description	Code	Description
0	No alarm	---	28 PG error Pg
1	Overcurrent (During acceleration)	OC1	31 Memory error Er1
2	Overcurrent (During deceleration)	OC2	32 KEYPAD panel communication error Er2
3	Overcurrent (While running at constant speed)	OC3	33 CPU error Er3
5	Ground fault	EF	34 Option communication error Er4
6	Overvoltage (During acceleration)	OU1	35 Option error Er5
7	Overvoltage (During deceleration)	OU2	36 Operating proc.error Er6
8	Overvoltage (While running at constant speed)	OU3	37 Output phase loss error Er7
10	Undervoltage	LU	38 RS485 communication error Er8
11	Input phase lose	Lin	71 Check sum error
14	Fuse blown	FUS	72 Parity error
16	Output wiring error	Er7	73 Other errors
17	Overheat of heat sink in inverter	OH1	74 Format error
18	External alarm input	OH2	75 Command error
19	Overheat of unit internal temp.	OH3	76 Priority of link
22	Overheat of DB resistance	dbH	77 No writing right for error
23	Electronic thermal overload relay (Motor1)	OL1	78 Function code error
24	Electronic thermal overload relay (Motor2)	OL2	79 Forbidden writing error
25	Electronic thermal over load relay (Inverter)	OLU	80 Data error
27	Overspeed	OS	81 Error during writing

8.5 PARAMETER DATA FORMAT

The data formats for various parameter data of the inverters are defined here. The data shall be prepared according to the following data format specifications. The instruction manual of inverter shall be referred to for the range and unit of data. The communication number is used to access inverter parameters through the fieldbus option and to configure Global Database Transaction.

List of parameter data format

Code	Communication No. decimal (Hex.)	Name	Data Format	Code	Communication No. decimal (Hex.)	Name	Data Format
-	0	-	-	M31	45(2D)	Setting frequency at alarming	[5]
S01	1(1)	Setting frequency (p.u.)	[2]			(Final data)	
-	2(2)	-	-	M32	46(2E)	Output frequency at alarming	[2]
-	3(3)	-	-	M33	47(2F)	Torque calculation value at alarming	[6]
-	4(4)	-	-	M34	48(30)	Torque current at alarming	[6]
S05	5(5)	Setting frequency	[5]	M35	49(31)	Output frequency 1 at alarming	[5]
S06	6(6)	Operation command	[11]	M36	50(32)	Input power at alarming	[5]
S07	7(7)	Universal Do	[12]	M37	51(33)	Output current at alarming	[5]
S08	8(8)	Acceleration time	[3]	M38	52(34)	Output voltage at alarming	[3]
S09	9(9)	Deceleration time	[3]	M39	53(35)	Operation command at alarming	[11]
S10	10(A)	Torque limit level 1	[5] *1	M40	54(36)	Operating state at alarming	[13]
S11	11(B)	Torque limit level 1	[5] *1	M41	55(37)	Y1-Y5 output terminal data at alarming	[12]
S12	12(C)	Universal Ao	[2]				
-	13(D)	-	-	M42	56(38)	Operating time at alarming	[1]
-	14(E)	-	-	M43	57(39)	DC link circuit voltage at alarming	[1]
M01	15(F)	Setting frequency (Final data)	[2]	M44	58(3A)	Inverter internal air temp. at alarming	[1]
-	16(10)	-	-				
-	17(11)	-	-	M45	59(3B)	Cooling fin temp. at alarming	[1]
-	18(12)	-	-	M46	60(3C)	Life of main circuit capacitor	[3]
M05	19(13)	Setting frequency (Final data)	[5]	M47	61(3D)	Life of printed circuit board capacitor	[1]
M06	20(14)	Output frequency 1	[2]	M48	62(3E)	Life of cooling fan	[1]
M07	21(15)	Torque calculation value	[6]	-	63(3F)	-	-
M08	22(16)	Torque current	[6]	-	64(40)	-	-
M09	23(17)	Output frequency 1	[5]	-	65(41)	-	-
M10	24(18)	Input power	[5]	-	66(42)	-	-
M11	25(19)	Output current	[5]	-	67(43)	-	-
M12	26(1A)	Output voltage	[3]	-	68(44)	-	-

M13	27(1B)	Operation command (Final data)	[11]	-	69(45)	-	-
M14	28(1C)	Operating state	[13]	F00	70(46)	Data protection	[1]
M15	29(1D)	Y1-Y5 output terminal data	[12]	F01	71(47)	Frequency command 1	[1]
M16	30(1E)	Fault memory 0	[1]	F02	72(48)	Operation method	[1]
M17	31(1F)	Fault memory (1st prior)	[1]	F03	73(49)	Maximum output frequency 1	[1]
M18	32(20)	Fault memory (2nd prior)	[1]	F04	74(4A)	Base frequency 1	[1]
M19	33(21)	Fault memory (3rd prior)	[1]	F05	75(4B)	Rated voltage 1	[1]
M20	34(22)	Operating time	[1]	F06	76(4C)	Maximum output voltage 1	[1]
M21	35(23)	DC link circuit voltage	[1]	F07	77(4D)	Acceleration time 1	[10]
-	36(24)	-	-	F08	78(4E)	Deceleration time 1	[10]
M23	37(25)	Type code	[14]	F09	79(4F)	Torque boost 1	[3]
M24	38(26)	Capacity code	[9]	F10	80(50)	Electronics thermal overload relay 1 (Selection)	[1]
M25	39(27)	ROM version	[1]				
M26	40(28)	Transmission error processing code	[1]	F11	81(51)	Electronics thermal overload relay 1 (Level)	[10]
M27	41(29)	Setting frequency at alarming (Final data)	[2]	F12	82(52)	Electronics thermal overload relay 1	[3]
				F13	83(53)	Electronics thermal overload relay (Braking resistor)	[1]
-	42(2A)	-	-	F14	84(54)	Restart after momentary power failure (Selection)	[1]
-	43(2B)	-	-				
-	44(2C)	-	-				

*1) 999 is treated as 7FFF_H.

Code	Communication No. decimal (Hex.)	Name	Data Format	Code	Communication No. decimal (Hex.)	Name	Data Format
F15	85(55)	Frequency limiter (High)	[1]	E37	135(87)	Overload early warning 2 (level)	[10]
F16	86(56)	Frequency limiter (Low)	[1]	E40	136(88)	Display coefficient A	[10]
F17	87(57)	Gain (for frequency setting signal)	[3]	E41	137(89)	Display coefficient B	[10]
F18	88(58)	Bias frequency	[4]	E43	138(8A)	LED monitor (Display selection)	[1]
F20	89(59)	DC brake (Starting frequency)	[3]	E44	139(8B)	LED monitor (Display at STP mode)	[1]
F21	90(5A)	DC brake (Braking level)	[1]	E45	140(8C)	LCD monitor (Display selection)	[1]
F22	91(5B)	DC brake (Braking time)	[3]	C01	141(8D)	Jump frequency 1	[1]
F23	92(5C)	Starting frequency	[3]	C02	142(8E)	Jump frequency 2	[1]
F24	93(5D)	Starting frequency (Holding time)	[3]	C03	143(8F)	Jump frequency 3	[1]
F25	94(5E)	Stop frequency	[3]	C04	144(90)	Jump frequency (Width)	[1]
F26	95(5F)	Motor sound (Carrier frequency)	[1] *1	C05	145(91)	Multi -step frequency 1	[5]
F27	96(60)	Motor sound (Sound tone)	[1]	C06	146(92)	Multi -step frequency 2	[5]
F30	97(61)	FMA terminal (Voltage adjust)	[1]	C07	147(93)	Multi -step frequency 3	[5]
F31	98(62)	FMA terminal (Function selection)	[1]	C08	148(94)	Multi -step frequency 4	[5]
F33	99(63)	FMP terminal (Pulse rate multiplier)	[1]	C09	149(95)	Multi -step frequency 5	[5]
F34	100(64)	FMP terminal (Voltage adjust)	[1]	C10	150(96)	Multi -step frequency 6	[5]
F35	101(65)	FMP terminal (Function selection)	[1]	C11	151(97)	Multi -step frequency 7	[5]
F36	102(66)	30Ry operation mode	[1]	C20	152(98)	Jogging frequency	[5]
F40	103(67)	Torque limit 1 (Driving)	[1]	C30	153(99)	Frequency setting 2	[1]
F41	104(68)	Torque limit 1 (Braking)	[1]	C31	154(9A)	Analog input offset (terminal 12) /	[4]
F42	105(69)	Torque vector control 1	[1]			Analog input bias (terminal 12)	
E01	106(6A)	X1 terminal function	[1]	C32	155(9B)	Analog input offset (terminal C1) /	[4]
E02	107(6B)	X2 terminal function	[1]			Analog input gain (terminal 12)	
E03	108(6C)	X3 terminal function	[1]	C33	156(9C)	Analog filter	[5]
E04	109(6D)	X4 terminal function	[1]	P01	157(9D)	Motor 1 (Number of poles)	[1]
E05	110(6E)	X5 terminal function	[1]	P02	158(9E)	Motor 1 (Capacity)	[5]
E06	111(6F)	X6 terminal function	[1]	P03	159(9F)	Motor 1 (Rated current)	[10]
E07	112(70)	X7 terminal function	[1]				
E08	113(71)	X8 terminal function	[1]	P05	161(A1)	Motor 1 (On-line tuning)	[1]
E09	114(72)	X9 terminal function	[1]	P06	162(A2)	Motor 1 (No-load current)	[10]
E10	115(73)	Acceleration time 2	[10]	P07	163(A3)	Motor 1 (%R1)	[5]
E11	116(74)	Deceleration time 2	[10]	P08	164(A4)	Motor 1 (%X)	[5]
E12	117(75)	Acceleration time 3	[10]	P09	165(A5)	Motor 1 (Slip compensation control)	[5]

E13	118(76)	Deceleration time 3	[10]	H03	166(A6)	Data initializing	[1] *2
E14	119(77)	Acceleration time 4	[10]	H04	167(A7)	Auto-reset (Times)	[1]
E15	120(78)	Deceleration time 4	[10]	H05	168(A8)	Auto-reset(Reset interval)	[1]
E16	121(79)	Torque limiter 1(Driving)	[1]	H06	169(A9)	Fan stop operation	[1]
E17	122(7A)	Torque limiter 1 (Braking)	[1]	H07	170(AA)	ACC/DCC pattern (Mode selection)	[1]
E20	123(7B)	Y1 terminal function	[1]	H08	171(AB)	Reverse phase sequence lock	[1]
E21	124(7C)	Y2 terminal function	[1]	H09	172(AC)	Start mode (Pick-up mode)	[1]
E22	125(7D)	Y3 terminal function	[1]	H10	173(AD)	Energy-saving operation	[1]
E23	126(7E)	Y4 terminal function	[1]	H11	174(AE)	Deceleration mode	[1]
E24	127(7F)	Y5A, Y5C terminal functions	[1]	H12	175(AF)	Instantaneous overcurrent limiting	[1]
E30	128(80)	Frequency arrival (FAR) (Detecting width)	[3]	H13	176(B0)	Auto-restart (Restart time)	[3]
				H14	177(B1)	Auto-restart (Frequency fall rate)	[5]
E31	129(81)	Frequency detection 1 (FDT) (level)	[1]	H15	178(B2)	Auto-restart (Holding DC voltage)	[1]
				H16	179(B3)	Auto-restart (OPR command selfhold time)	[3] *3
E32	130(82)	Frequency detection (FDT) (Hysteresis width)	[3]			H18	180(B4)
E33	131(83)	Overload early warning (Mode selection)	[1]	H19	181(B5)	Active drive	[1]
				H20	182(B6)	PID control (Mode selection)	[1]
E34	132(84)	Overload early warning 1 (level)	[10]	H21	183(B7)	PID control (Feed back signal)	[1]
E35	133(85)	Overload early warning (Timer time)	[3]	H22	184(B8)	PID control (P-Gain)	[5]
E36	134(86)	Frequency detection 2 (FDT) (level)	[1]	H23	185(B9)	PID control (I-time)	[3]
				H24	186(BA)	PID control (D-time)	[5]
				H25	187(BB)	PID control (Feedback filter)	[3]

*1) 0.75 kHz is treated as 0000H

*2) The communication might not be able to be continued by writing (data 1).

*3) 999 is treated as 03E7H (99.9).

Code	Communication No. decimal (Hex.)	Name	Data Format	Code	Communication No. decimal (Hex.)	Name	Data Format
H26	188(BC)	PTC thermistor (Mode selection)	[1]	o36	235(EB)	Bus Configuration Parameter 07	[1]
H27	189(BD)	PTC thermistor (Level)	[5]	o37	236(EC)	Bus Configuration Parameter 08	[1]
H28	190(BE)	Droop operation	[4]	o38	237(ED)	Bus Configuration Parameter 09	[1]
H30	191(BF)	Serial link (Function selection)	[1]	o39	238(EE)	Bus Configuration Parameter 10	[1]
H31	192(C0)	RS485 (Address)	[1] *1	o40	239(EF)	Bus Configuration Parameter 11	[1]
H32	193(C1)	RS485 (Mode selection on error)	[1] *1	o41/	240(F0)	Bus Configuration Parameter 12/	[1] /
H33	194(C2)	RS485 (Timer time)	[3] *1	(o09)		Base side number of encoder pulses	[1]
H34	195(C3)	RS485 (Baud rate)	[1] *1	o42/	241(F1)	Bus Configuration Parameter 13/	[1] /
H35	196(C4)	RS485 (Data length)	[1] *1	(o10)		Time constant of pulse train input filter	[7]
H36	197(C5)	RS485 (Parity check)	[1] *1	o43/	242(F2)	Bus Configuration Parameter 14/	[1] /
H37	198(C6)	RS485 (Stop bits)	[1] *1	(o11)		Command pulse compensation coefficient 1	[1]
H38	199(C7)	RS485 (No response detection time)	[1] *1	o44/	243(F3)	Bus Configuration Parameter 15/	[1] /
H39	200(C8)	RS485 (Response interval)	[5] *1	(o12)		Command pulse compensation coefficient 2	[1]
A01	201(C9)	Maximum frequency 2	[1]	o45/	244(F4)	Bus Configuration Parameter 16/	[1] /
A02	202(CA)	Base frequency 2	[1]	(o13)		Main speed regulator gain	[3]
A03	203(CB)	Rated voltage 2 (at base speed)	[1]	o46/	245(F5)	Bus Configuration Parameter 17/	[1] /
A04	204(CC)	Maximum output voltage 2	[1]	(o14)		APR P gain	[5]
A05	205(CD)	Torque boost 2	[3]	o47/	246(F6)	Bus Configuration Parameter 18/	[1] /
A06	206(CE)	Electronics thermal 2 (Selection)	[1]	(o15)		Z phase matching gain	[3]
A07	207(CF)	Electronics thermal 2 (Level)	[10]	o48/	247(F7)	Bus Configuration Parameter 19/	[1] /
A08	208(D0)	Electronics thermal 2 (Thermal time constant)	[3]	(o16)		Offset angle	[1]
A09	209(D1)	Torque vector control 2	[1]	o49/	248(F8)	Bus Configuration Parameter 20/	[1] /
A10	210(D2)	Motor 2 (Number of motor2 pdes)	[1]	(o17)		Detecting angle width for completion of synchronizing	[1]
A11	211(D3)	Motor 2 (Capacity)	[5]	o50/	249(F9)	Bus Configuration Parameter 21/	[1] /
A12	212(D4)	Motor 2 (Rated current)	[10]	(o18)		Too mach deviation	[1]
A14	214(D6)	Motor 2 (On-line tuning)	[1]	o51	250(FA)	Bus Configuration Parameter 22/	[1]
A15	215(D7)	Motor 2 (No load current)	[10]	o52	251(FB)	Bus Configuration Parameter 23/	[1]
A16	216(D8)	Motor 2 (%R1 setting)	[5]	o53	252(FC)	Bus Configuration Parameter 24/	[1]
A17	217(D9)	Motor 2 (%X setting)	[5]	o54	253(FD)	Bus Configuration Parameter 25/	[1]
A18	218(DA)	Motor 2 (Slip compensation control 2)	[5]	o55	254(FE)	Bus Configuration Parameter 26/	[1]
o01	219(DB)	Speed command system /	[15]	-	255(FF)	-	-

		automatic speed control system					
o02	220(DC)	Time constant of PG vector and speed command filter	[7]				
o03	221(DD)	Number of feedback PG pulses	[1]				
o04	222(DE)	Constant P of feedback speed controller	[5]				
o05	223(DF)	Constant I of feedback speed Controller	[7]				
o06	224(E0)	Time constant of feedback speed detection filter	[7]				
o07	225(E1)	Feedback pulse correction coefficient 1	[1]				
o08	226(E2)	Feedback pulse correction coefficient 2	[1]				
o27	227(E3)	Mode selection on error	[1]				
o28	228(E4)	Timer time setting	[3]				
o30	229(E5)	Bus Configuration Parameter 01	[1]				
o31	230(E6)	Bus Configuration Parameter 02	[1]				
o32	231(E7)	Bus Configuration Parameter 03	[1]				
o33	232(E8)	Bus Configuration Parameter 04	[1]				
o34	233(E9)	Bus Configuration Parameter 05	[1]				
o35	234(EA)	Bus Configuration Parameter 06	[1]				

*1) Read-only from communication.

8.6 DATA FORMAT SPECIFICATION

All data within the data field of the communication frame consist of 16 bits binary data.

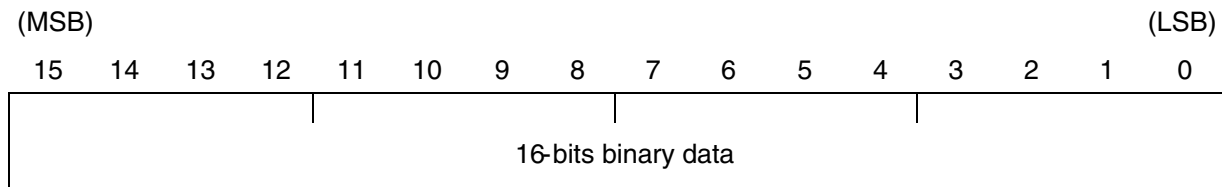

(Negative data is treated with two's complement.)

Data format [1] Integer data (Positive): Min. unit 1

Example) If F15 (Frequency limiter, high limit) = 60 Hz,

$$60 * 1 = 60 = 003C_H$$

->

0	0	3	C
---	---	---	---

Data format [2] Integer data (Positive, negative): Min. unit 1

Example) If F18 (Bias frequency) = -20 Hz,

$$-20 * 1 = -20 = FFEC_H(\text{two's complement})$$

->

F	F	E	C
---	---	---	---

Data format [3] Decimal data (Positive): Min. unit 0.1

Example) If F17 Gain (for frequency setting signal) = 100.0%,

$$100.0 * 10 = 1000 = 03E8_H$$

->

0	3	E	8
---	---	---	---

Data format [4] Decimal data (Positive, negative): Min. unit 0.1

Example) If H28 (Droop operation) = -5.0Hz,

$$-5.0 * 10 = -50 = FFCE_H(\text{two's complement})$$

->

F	F	C	E
---	---	---	---

Data format [5] Decimal data (Positive): Min. unit 0.01

Example) If C05 (Multi-step frequency 1) = 50.25 Hz,

$$50.25 * 100 = 5025 = 13A1_H$$

->

1	3	A	1
---	---	---	---

Data format [6] Decimal data (Positive, negative): Min. unit 0.01

Example) If M07 (Actual torque value) = -85.38%,

$$-85.38 * 100 = -8538 = DEA6_H(\text{two's complement})$$

->

D	E	A	6
---	---	---	---

Data format [7] Decimal data (Positive): Min. unit 0.001

Example) If o05 (Constant I of feedback speed controller) = 0.105s,

$$0.105 * 1000 = 105 = 0069_H$$

->

0	0	6	9
---	---	---	---

Data format [8] Decimal data (Positive, negative): Min. unit 0.001

Example) If being -1.234,

$-1.234 * 1000 = -1234 = \text{FB2E}_{\text{H}}$ (two's complement) ->

F	B	2	E
---	---	---	---

Data format [9] Capacity code

Code	Capacity (kW)	Code	Capacity (kW)	Code	Capacity (kW)
5	0.05	1100	11	11000	110
10	0.1	1500	15	13200	132
20	0.2	1850	18.5	16000	160
40	0.4	2200	22	20000	200
75	0.75	3000	30	22000	220
150	1.5	3700	37	25000	250
220	2.2	4500	45	28000	280
370	3.7	5500	55	31500	315
550	5.5	7500	75	35500	355
750	7.5	9000	90	40000	400

Example) If 30kW

Since $30 * 100 = 3000 = 0\text{BB}8\text{H}$

->

0	B	B	8
---	---	---	---

Data format [10] Exponential data (ACC/DEC time, current value, display coefficient)

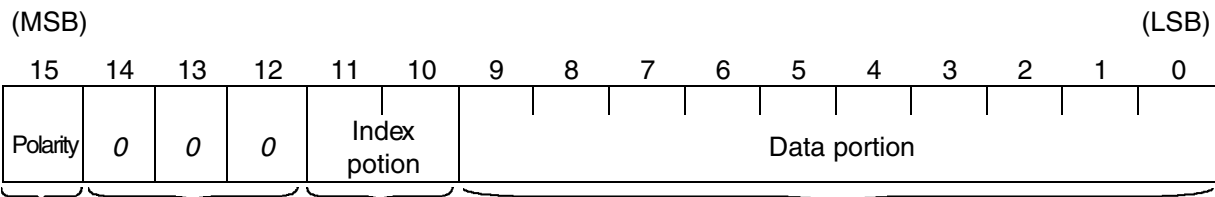

Not used

0: 0.01	*	001-999	(0.00- 9.99)
1: 0.1	*	100-999	(10.0- 99.9)
2: 1	*	100-999	(100- 999)
3: 10	*	100-999	(1000- 3600)

0: Positive (+), 1:Negative)(-)

Example) F07 (Acceleration time 1) = 20.0 s,

$20.0 = 0.1 * 200$

->

0	4	C	8
---	---	---	---

Data format [11] Operation command

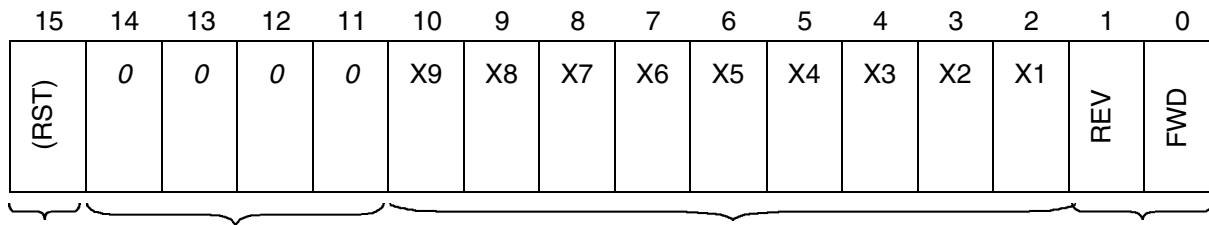

Alarm reset

Not used

Multi -function command

FWD: Forward rotation command

REV: Reverse rotation command

(All bits are ON by 1)

Example) If M13 (Operation command, Final command) = FWD, X1, X5 = ON,

0000 0000 0100 0101_b = 0045_H

->

0	0	4	5
---	---	---	---

Data format [12] Universal output terminal

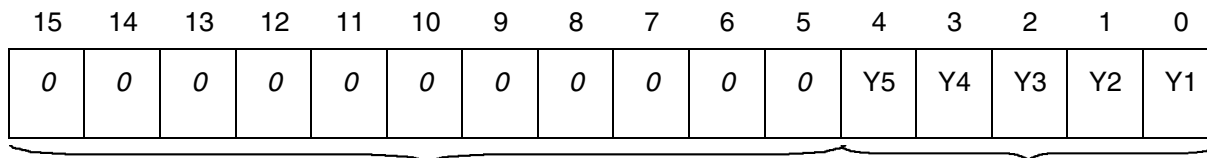

Not used

Universal command

(All bits are ON by 1)

Example) If M15 (Universal output terminal) = Y1, Y5 = ON,

0000 0000 0001 0001_b = 0011_H

->

0	0	1	1
---	---	---	---

Data format [13] Operating status

15	14	13	12	11	10	9	8	7	6	5	4	3	2	1	0
-	WR	RL	ALM	DEC	ACC	IL	VL	TL	NUV	BRK	INT	EXT	REV	FWD	

(All bit are ON or active by 1)

- | | | | |
|------|--|------|------------------------|
| FWD: | In forward operation | IL: | In current limiting |
| REV: | In reverse operation | ACC: | In acceleration |
| EXT: | In DC braking (or in preexcitation) | DEC: | In deceleration |
| | | ALM: | Alarm |
| INT: | Inverter Base Of | RL: | Transmission valid |
| BRK: | In braking | WR: | Function writing right |
| NUV: | DC link voltage isestablishment
(Undervoltage condition at 0) | | 0: Keypad panel |
| | | | 1: RS485 |
| TL: | In torque limiting | | 2: Link (option) |
| VL: | In voltage limiting | | |

Example) Omitted (Monitoring method is similar as in the formats [11] and [12].)

Data format [14] Type code

15	14	13	12	11	10	9	8	7	6	5	4	3	2	1	0
Unit type				Generation				Series				Voltage series			

Code	Type	Generation	Series	Voltage series
1	VG	11thseries	For Japan	100V single phase
2	G	-	For Asia	200V single phase
3	P	-	For China	200V threephase
4	E	-	For Europe	400V three phase
5	C	-	For USA	575V three phase
6	S	-	-	-

Data format [15] Code setting (1 - 4 figures)



Example) If "o22: Ai function selection" = 123,
Since 123 = 0123_H



Data format [16] Auto tuning

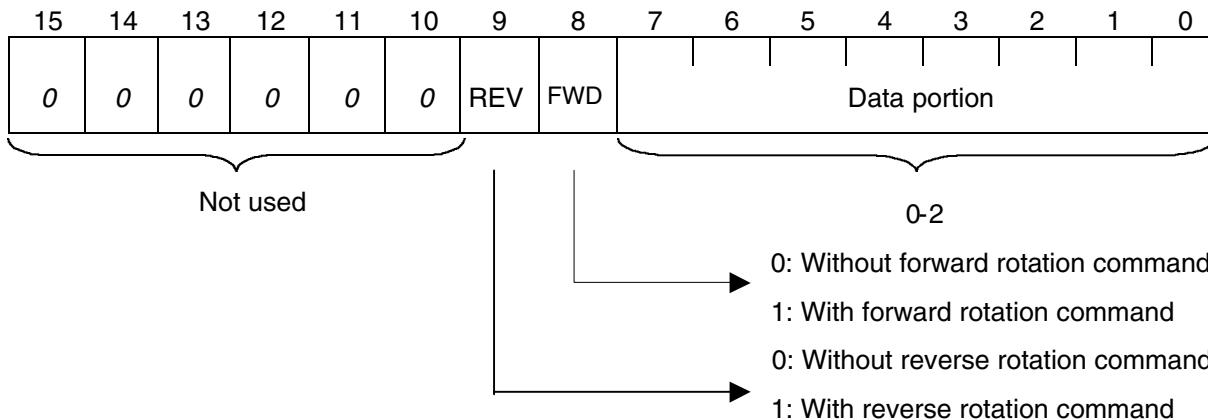

Example) If P04 (motor 1 auto - tuning)=1: Forward rotation

Since 0000 0001 0000 0001 b =0101 H

