

DY4 PLUS

SOLID STATE BRAKE

P/N: X039001
REV: 12/01

CONTENTS

1.0 DESCRIPTION	1
1.1 Overview	1
1.2 Standard Features	1
2.0 SPECIFICATIONS	2
2.1 Electrical	2
2.2 Electrical Protection	3
2.3 Mechanical	3
2.4 Adjustments	3
3.0 RECEIVING AND INSTALLATION	4
3.1 Installation	4
3.2 Derating Data	4
3.3 Wiring	4
3.4 Auxiliary Connections	5
4.0 START-UP	7
4.1 Inspection	7
4.2 Pre-Start Adjustments	7
4.3 Starting	8
5.0 TROUBLESHOOTING	9
5.1 Diagnostics	9
6.0 WIRING DIAGRAM	10
7.0 DIMENSIONS AND WEIGHTS	11
8.0 SPARE PARTS	12
9.0 WARRANTY	13

1.0 DESCRIPTION

1.1 Overview

Saftronics DY4 Plus Series Electronic Motor Brakes provide a continuously controlled DC current to an AC induction motor to achieve rapid and smooth stopping. The unit has been designed as a stand-alone brake package to be used with across-the-line starters, or as an option to the Saftronics Solid State Starter. It may also be used with other reduced voltage starters, subject to compatibility of interlocks.

1.2 Standard Features

Universal Source Matching (USM™)

The DY4 Plus Brake can operate with any AC supply of 200 to 600 VAC, 45 to 65 Hz, irrespective of phase rotation.

Current Controlled

The DY4 Plus Brake is designed with current feedback. This provides the current, and hence consistent braking torque, every time dynamic braking is applied, regardless of motor temperature.

Fully Automated Operation

When the motor “STOP” push-button is pressed, the motor contactor opens. The DY4 Plus senses this event and applies controlled DC current. When the motor reaches zero speed, the DY4 Plus senses this condition and removes the DC supply. The unit has a built-in “backup timer” to the auto zero speed operation. This backup timer adjustment can be used with the auto zero speed sensing feature switched off to provide timed braking.

Full-Wave Half-Controlled Rectifier

The power unit consists of 4 conservatively rated SCR’s connected as a full-wave rectifier with free-wheeling effect. This configuration provides the maximum DC braking current with a minimum AC supply current.

Dual Connection

The DY4 Plus Brake can be used as a stand-alone brake when used with an electromechanical starter, or can be used as an add-on option to the Saftronics Solid State Starter.

Dual Stopping Mode

Auto Zero Speed Stop

Auto Zero Speed Stop is the standard mode of operation, and automatically removes braking current as soon as zero speed is reached.

Timed Only Stop

Timed Only Stop mode is provided for special applications. The DC injection brake is on for an adjustable time regardless of motor speed.

NOTE: *When ordered as an integrated option on Solid State Starter, all interlocking is automatic. When used as a “Stand Alone” add-on to a solid state starter, extra interlocking may be required to prevent false trips.*

2.0 SPECIFICATIONS

2.1 Electrical

Power

Single phase, 200 to 600 Volts, 45 to 65 Hz (for a three phase supply, use L2 and L3 or S and T).

Control

115 VAC, 45 to 65 HZ, 20 VA

Duty Cycle

One 30 second stop every 15 minutes at maximum current. Consult factory for suitability of other duty cycles.

Operator Devices

No direct operator devices are required.

Input Contacts

1 normally open auxiliary from the motor starter. This must be a clean standard auxiliary contact on the main motor starter. Use of pilot relays or dirty auxiliary contacts may result in improper operation, and damage to the brake or other equipment.

Output Contacts

Brake On - 1 NO/NC contact rated at 5 AMPS, 220 VAC.

Auxiliary Inputs/Outputs

Zero speed detect inhibit input for timer operated braking.

DB inhibit input to interrupt or preclude the braking cycle.

Auxiliary start input to manually initiate the braking cycle.

Zero speed open collector, 24 VDC, 50 mA output.

Zero speed open collector, 24 VDC, 50 mA pulse output.

Table 1

Model DY4+	Recommended Maximum HP Rating					Current Amps		Option AC Line Fuse Rating Amps
	208V	230V	380/415V	460V	575V	MIN	MAX	
15	3	5	7.5	10	15	6	30	30
40	10	15	25	30	40	16	80	60
75	20	25	50	50	75	30	150	100
125	40	50	75	100	125	50	250	200
180	60	75	125	150	200	75	360	250
780	150	200	350	400	500	200	960	600
720	250	300	500	600	700	300	1440	1000

NOTE: The table indicates Maximum recommended HP for general purpose use. Brakes may be re-rated for operation of larger or smaller motors, depending on application and duty cycle. Brakes may be derated for higher HP in specific applications by consulting factory.

CAUTION: *The DY4 Plus Brake unit is not designed as a holding brake. In case of any power interruption, loss of braking will occur immediately.*

CAUTION: *The zero speed outputs are not to be used as an indication that the motor is at rest.*

2.0 SPECIFICATIONS (con't)

2.2 Electrical Protection

Wiring Diagrams

Refer to section 6.0 for wiring diagrams.

Motor Overload

The DY4 Plus Brake does not provide motor overload protection, however, this can be provided as an option.

Short Circuit Protection

The NEC requires fusing of all motor branch circuits, however optional semiconductor AC line fusing may enhance protection of the brake and starter.

2.3 Mechanical

This section intentionally left blank.

2.4 Adjustments

RV2 Current

This adjustment sets amount of DB current, over a 6:1 range. The braking torque is proportional to the square of the DC current. Typically, the DC current is set to 200% of the AC current rating of the motor. For example, for a motor rated at 120A, the DC current is set to 240 amps DC.

SW1 - Zero Speed Dwell Time - Dip Switches

This setting, variable between 0.5 sec. and 7.5 sec in 0.5 sec. increments, determines how long DB current continues to be applied after zero speed has been detected.

SW2 - Backup Timer - Dip Switches

DB Time - Adjustable between 1 sec. and 255 sec. in 1 sec. increments. When zero speed is disabled, the DY4 Plus Brake will apply DC current to the motor for the time set by this adjustment.

When in the automatic zero speed sensing mode, DB time setting is a backup only. DC current will be removed once the time set by this adjustment expires, regardless of the zero speed detector. Thus, it is important that the backup DB time setting be set at 5-10 seconds longer than the stopping time of the motor under DB conditions.

The timing starts when the M contactor opens (or starter is stopped). If the M auxiliary fails to open, braking is not applied.

P1 240V/480V Link

This link adjusts the response of the brake circuit to the decay of the residual motor voltage after AC power has been removed.

CAUTION: *Excessive starts and stops will result in motor overheating. Customer must ensure that the duty imposed on the motor during starting and stopping is within the motor's thermal capability.*

3.0 RECEIVING AND INSTALLATION

3.1 Installation

The cabinet containing the DY4 Plus Brake must be installed in an area where the following conditions exist:

Ambient temperature does not exceed 40°C (104°F).

Ambient temperature is not less than 10°C (50°F).

Altitude above sea level is 3300 feet (1000 m) or less.

Ambient air is reasonable clean, dry and free of flammable or combustible vapors, steam, or corrosive gases.

The cabinet must be installed away from any heat source, and a minimum of 1 foot (30 cm) is required around the air inlet and outlet, on ventilated units.

The DY4 Plus Brake has been designed for 50°C maximum inside the enclosure.

3.2 Derating Data

When the unit is installed in poor environmental conditions, it must be derated as follows:

1.5% per °C above 40°C, or 0.75% per °F above 104°F.

1% for every 100 m above 1000 m, or for every 300 feet above 3300 feet.

3.3 Wiring

The DY4 Plus Brake is to be connected according to the NEC and any other applicable Electrical Codes in the customer's area. The chassis must be grounded to earth ground.

Power Factor Capacitor Connection

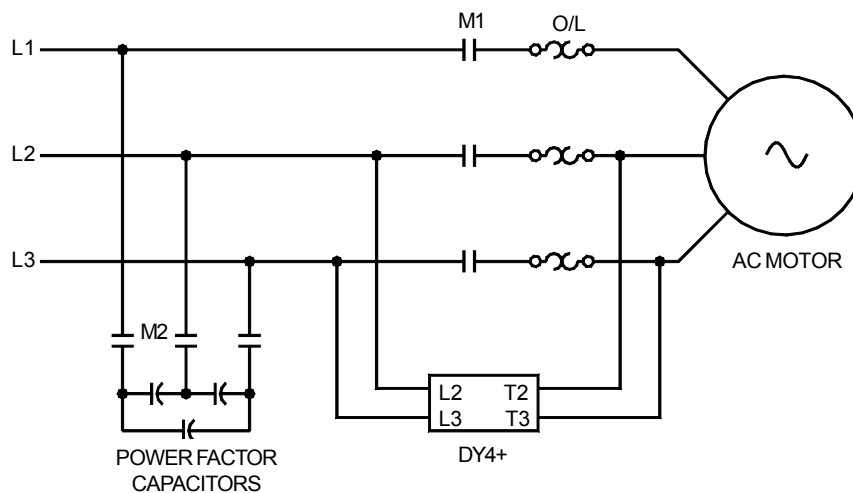

Suppression of Inductive AC Loads

All Inductive AC Loads (contactors, relay or solenoid coils) in close proximity, or on the same 120V source must utilize R-C Snubbers to suppress inductive voltage spikes caused by de-energizing these loads. Failure to suppress these spikes may cause improper operation to damage the brake or other components.

CAUTION: Power factor capacitors, when utilized, must be connected to the line side of the brake, and never to the load side

3.0 RECEIVING AND INSTALLATION (con't)

3.4 Auxiliary Connections

External Zero Speed Relay

A relay with a 24 Volt DC coil connected as shown will be energized when zero speed is detected and will remain in that state until the starter auxiliary contact on terminals 5 and 6 (J3) are closed again.

*A diode must be installed across the relay coil to prevent damage to internal circuitry when the relay is de-energized.

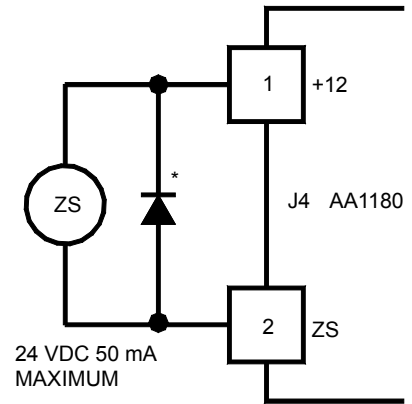

Zero Speed Detection Inhibit

To prevent the Zero Speed Detection circuit from operating, connect a wire jumper as shown. In this mode, braking time is set by backup timer switch S2.

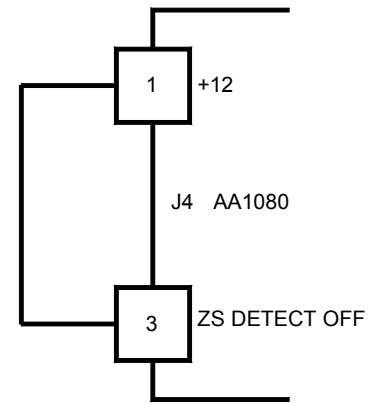

DB Inhibit

Braking current can be immediately interrupted by closing a normally open switch or contact connected as shown. The switch could, for example, be the N.O. contact of a thermal overload relay connected in the DC leg of the output T2. If the switch is opened before the backup timer expires, DB will re-initiate.

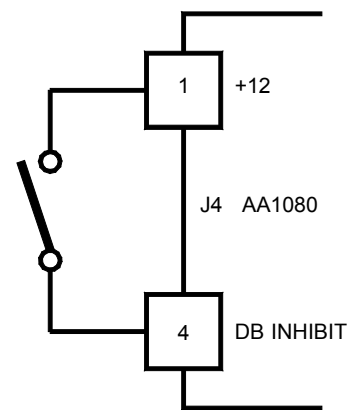

3.0 RECEIVING AND INSTALLATION (con't)

Zero Speed Pulse

A relay with a 24 Volt DC coil connected as shown will be energized when zero speed is detected and will remain in that state until the braking current ceases. LED DS4 is also illuminated for this period of time. The length of the ZS pulse is determined by the setting of SW1 (see page 4).

*A diode must be installed across the relay coil to prevent damage to internal circuitry when the relay is de-energized.

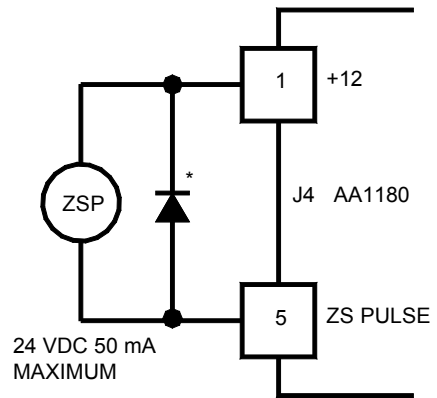

Auxiliary Start

When a normally closed switch connected as shown is opened and there is no voltage on terminals T2 and T3 (V and W) of the motor, the DB cycle starts.

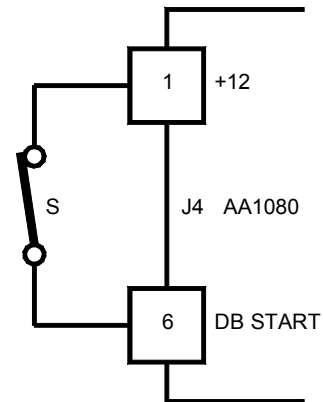

Re-Starting During the DB Cycle

A two pole push-button connected as shown can be used to interrupt the braking current and restart the motor before zero speed has been reached. If the push-button is pressed and held for 2 seconds during the braking cycle, the DC current will be interrupted and the motor restarted.

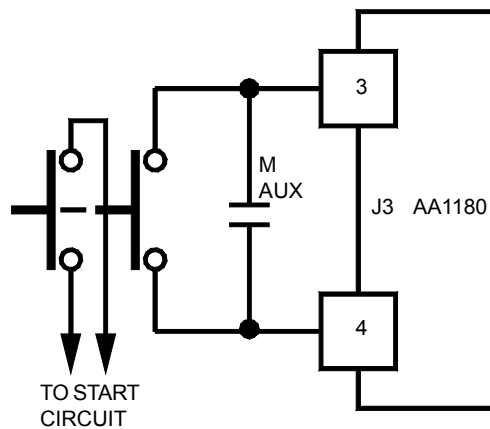

4.0 START-UP

4.1 Inspection

Ensure that the brake has been installed according to the previous guidelines. Also, ensure that the unit has been wired according to the schematics. Check that all connections are tight. Check that the motor can rotate freely.

4.2 Pre-Start Adjustments

Before power is applied to the brake, the following settings should be made:

P1 Setting

AC Supply Voltage	P1 Setting
200 - 370 VAC	240V
380 - 600 VAC	480V

RV2 Current

Fully counterclockwise (CCW). Minimum braking current.

SW1 Dwell Time

Set to 0.5 seconds. Set SW1-1 to ON and SW1-2, 3, 4 to OFF

SW2 Backup Time

Set to 32 seconds. Set SW2-1,2,3,4,5,7,8 to OFF and SW2-6 to ON.

Use a DC clamp-on ammeter around the wire connected to motor terminal T2. An AC meter in the output circuit will not read properly and if used on either L1 or L2 will only indicate approximately 50% of the DC current.

Temporarily connect a single pole toggle switch between terminals J4-1 and J4-4 to inhibit braking current in case of emergency. Set the switch to the open position.

4.0 START-UP (con't)

4.3 Starting

Power-Up

Once the brake has been checked and set up, it is ready for power. Check that all personnel are clear of the brake and motor, then apply power. +12 V LED DS3 must be illuminated. If it is not see page 9.

Starting

Press the START push-button and check that the motor accelerates to full speed. MOTOR RUNNING LED DS1 will illuminate. If not, see troubleshooting page 9.

Stopping

Press the STOP push-button. MOTOR RUNNING LED DS1 will go off and DB ON LED DS2 will illuminate.

As the motor is braking, adjust RV2, to obtain a DC current of approximately twice the motor FLA.

When the motor reaches full stop, the DC supply will be removed immediately by the DY4 Plus zero speed sensing circuit. This is indicated by a zero speed pulse on LED DS4 "ZS Pulse". If the unit fails to sense zero speed, momentarily close the "DB Inhibit" switch to turn off the brake unit.

If the current setting is not completed on the first attempt, open the inhibit switch and repeat the above two steps after waiting for a suitable time as determined by the duty cycle rating (see Duty Cycle, page 2).

The "Backup Timer" adjustment (SW2) must be set to match the actual stopping time plus 5 to 10 seconds. If the backup timer adjustment is set too low, the braking action will be removed before the motor reaches zero speed. For example, if the actual stopping time is 15 seconds, set SW2 between 20 and 25 seconds.

With some motors, the unit may not reliably detect zero speed. In such cases the brake will have to be operated in the Timed Only mode. To defeat the zero speed detector, connect a wire jumper between terminals J4-1 and J4-3 and set SW2 time to just slightly greater than the actual stopping time.

Once proper braking action has been achieved, record the DC current, DB time setting and actual stopping time on the inside of the panel door. Remove the DC ammeter and DB inhibit switch. The brake is now ready for operation.

CAUTION: *There is a shock hazard present even when the motor brake/starter is OFF.*

CAUTION: *Do not interrupt the AC supply to the brake during the braking cycle. Damage to the SCR's could result.*

5.0 TROUBLESHOOTING

5.1 Diagnostics

The DY4 Plus has several LED indicators for quick and simple diagnosis of the Brake status. In all cases an illuminated LED indicates that the labeled function is present or active.

+12 LED

This LED indicates the status of the internal +12 volt power supply. It is on when 120 VAC control voltage is present. All other LED's will be off if this LED is off. If this LED is off, check the 120 VAC supply across 1 and 2 on the control card terminal block. If it is okay, check the fuse on the control card. If both are okay, then change the DY4 Plus Control Module (P/N AA01-10).

Motor Running LED

This LED indicates the status of the starter auxiliary contact connected across terminals 3 and 4. The LED will be ON when the contact is closed, indicating that the starter is energized, and will remain on until the starter is de-energized. If this LED does not light when the starter has been activated, check the operation of the contact by measuring the DC voltage across terminals 3 and 4. If the voltage is below 2 volts, replace the cards. If the voltage is 2 volts or above, check the auxiliary contact and wiring.

DB on LED

This LED indicates the presence of the DC output of the Brake. This LED should turn on shortly after the starter is deactivated and the "Motor Running" LED goes out. It should stay on during the braking cycle and go out only after zero speed has been sensed or the backup timer has elapsed. If this LED fails to illuminate after the "Motor Running" LED goes out, check to ensure that the backup timer (SW2) is not set too short. Otherwise replace the DY4 Plus Control Module (P/N AA01-10).

ZS Pulse LED

This LED indicates that the brake has sensed zero speed. This LED should turn on shortly after the motor stops rotating, and will remain on for the "Zero Speed Dwell Time" set by SW1. If the Brake does not sense zero speed this LED will not illuminate, however, braking action will still be terminated by the backup timer. If this LED fails to illuminate at zero speed, check the T1 (zero speed sensing) lead from the motor for continuity. If this fails, consult the factory.

6.0 WIRING DIAGRAM

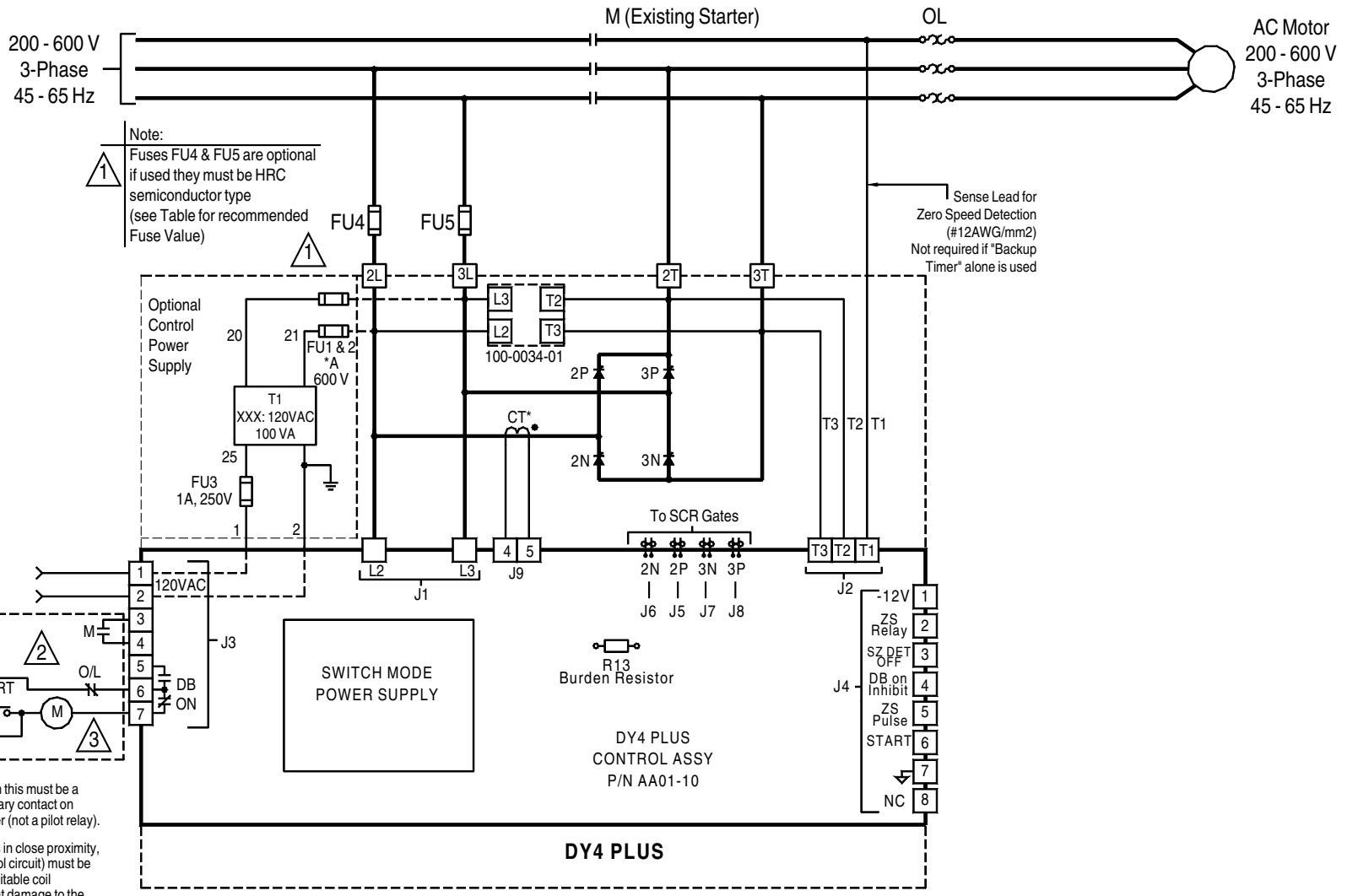

10

- 2 For reliable operation this must be a clean standard auxiliary contact on the main motor starter (not a pilot relay).
- 3 This coil (and all coils in close proximity, or on the same control circuit) must be suppressed with a suitable coil suppressor to prevent damage to the drive.



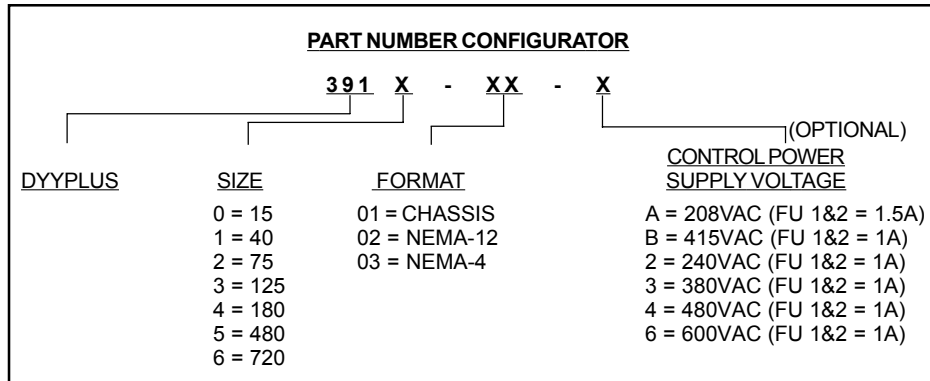

DY4 PLUS STAND ALONE BRAKE						
CT RATIO *	R13	PART NUMBER N4 / N12 / CHASSIS	DY4 PLUS SIZE	SCR TYPE	QTY	FU4 & FU5
1500 : 1 (x2 TURNS)	200	3910-03 / 3902-02 / 3910-01	15	N10SP03A	2	30A
1500 : 1	150	3911-03 / 3911-02 / 3911-01	40	N10SP03A	2	60A
1500 : 1	82	3912-03 / 3912-02 / 3912-01	75	N10SP06A	2	100A
2500 : 1	82	3913-03 / 3913-02 / 3913-01	125	N20SP10	2	200A
2500 : 1	56	3914-03 / 3914-02 / 3914-01	180	N20SP08	2	250A
5000 : 1	47	3915-03 / 3915-02 / 3915-01	480	N716452	4	600A
8500 : 1	47	3916-03 / 3916-02 / 3916-01	720	N719122	4	1000A

7.0 DIMENSIONS AND WEIGHTS

Size	Dimensions	Chassis	Nema 12
15 & 40	H x W x D in.	9.5 x 6.25 x 5.25	16 x 14 x 10
	H x W x D mm	241 x 159 x 133	406 x 356 x 254
	Lbs.* Kg.*	7 Lbs. 2.3 Kg.	27 Lbs. 12.2 Kg.
75	H x W x D in.	10 x 7.5 x 6	16 x 14 x 10
	H x W x D mm	254 x 190 x 152	406 x 356 x 254
	Lbs.* Kg.*	8 Lbs. 3.6 Kg.	28 Lbs. 12.7 Kg.
125 & 180	H x W x D in.	13 x 7.5 x 7	24 x 20 x 12
	H x W x D mm	330 x 190 x 178	609 x 508 x 304
	Lbs.* Kg.*	17 Lbs. 7.7 Kg.	72 Lbs. 32.7 Kg.
480	H x W x D in.	15.25 x 14 x 10	30 x 24 x 16
	H x W x D mm	387 x 356 x 254	762 x 609 x 406
	Lbs.* Kg.*	35 Lbs. 15.9 Kg.	115 Lbs. 52.2 Kg.
720	H x W x D in.	20 x 17 x 12.5	36 x 30 x 16
	H x W x D mm	508 x 432 x 317	914 x 762 x 406
	Lbs.* Kg.*	54 Lbs. 24.5 Kg.	175 Lbs. 80 Kg.

8.0 SPARE PARTS

Size	Part Number	Description	Quantity Used	Quantity Suggested	List Price Each
15	AA01-10 ⁽¹⁾	DY4 Plus Control Module	1	1	\$ 900
	100-0034-01	Snubber/Surge Absorber	1	1	160
	N10SP03A	SCR Module	2	1	150
	T5004-01	Current Transformer 1500:1	1	1	27
40	AA01-10 ⁽¹⁾	DY4 Plus Control Module	1	1	900
	100-0034-01	Snubber/Surge Absorber	1	1	160
	N10SP03A	SCR Module	2	1	150
	T5004-01	Current Transformer 1500:1	1	1	27
75	AA01-10 ⁽¹⁾	DY4 Plus Control Module	1	1	900
	100-0034-01	Snubber/Surge Absorber	1	1	160
	N10SP06A	SCR Module	2	1	160
	T5004-01	Current Transformer 1500:1	1	1	27
125	AA01-10 ⁽¹⁾	DY4 Plus Control Module	1	1	900
	100-0034-01	Snubber/Surge Absorber	1	1	160
	N20SP10	SCR Module	2	1	300
	T5003-03	Current Transformer 5000:1	1	1	55
180	AA01-10 ⁽¹⁾	DY4 Plus Control Module	1	1	900
	100-0034-01	Snubber/Surge Absorber	1	1	160
	N20SP08	SCR Module	2	1	495
	T5003-03	Current Transformer 5000:1	1	1	55
480	AA01-10 ⁽¹⁾	DY4 Plus Control Module	1	1	900
	100-0034-01	Snubber/Surge Absorber	1	1	160
	N716452E	SCR Module	4	2	240
	T5003-04	Current Transformer 8500:1	1	1	141
720	AA01-01 ⁽¹⁾	DY4 Plus Control Module	1	1	900
	100-0034-01	Snubber/Surge Absorber	1	1	160
	N719122E	SCR Module	4	2	397
	T5003-04	Current Transformer 8500:1	1	1	141

- (1) Original burden resistor (R13) must be reused on the replacement control card.
(2) Prices and Specifications subject to change.

9.0 WARRANTY

Saftronics warrants to buyer that products, and any services furnished hereunder will be free from defects in material, workmanship and title, and will be of the kind and quality specified in the quotation. The foregoing shall apply only to failures to meet said warranties (excluding any defects in title) which appear within one year from the date of shipment hereunder, provided, however, that if buyer, in the course of its regular and usual business, transfers title to or leases such products (including equipment incorporating such products) to a third party, such period shall run until one year from such transfer or lease or eighteen months from shipment by Saftronics whichever occurs first. The warranties and remedies set forth herein are conditioned upon (a) proper storage, installation, used and maintenance, and conformance with any applicable recommendations of Saftronics and, (b) buyer promptly notifying Saftronics of any defects and, if required, promptly making the product available for correction.

If any products or services fails to meet the foregoing warranties (except title), Saftronics shall thereupon correct any such failure either, at its option, (i) by repairing any defective or damaged part or parts of the products, or (ii) by making available FOB Saftronics plant or other point of shipment, any necessary repaired or replacement parts. The preceding paragraph sets forth the exclusive remedies for claims (except as to title) based on defect in or failure of products or services, whether claim in contract or tort (including negligence) and however instituted. Upon expiration of the warranty period, all such liability shall terminate. The foregoing warranties are exclusive and in lieu of all other warranties, whether written, oral, implied or statutory. No implied statutory warranty of merchantability or fitness for particular purpose shall apply and Saftronics will not be liable for any consequential damage arising from any product defect or failure to deliver on time. Saftronics does not warrant any products or services of others which buyer has designated.