

**Industrial Duty Solid State
Reduced Voltage, Current Regulated
AC Motor Starters**

EZ6

SOLID STATE STARTER

Most ratings are UL Listed, File #121753, & CSA approved, file #LR60954



EZ6

INSTRUCTION MANUAL

CONTENTS

Section 1.0: Description	
1.0 Overview	1
1.2 Standard Features	1
Section 2.0: Specifications	
2.1 Electrical	3
2.2 Electrical Protection	4
2.3 Mechanical	5
Section 3.0: Receiving & Installation	
3.1 Installation	6
3.2 Derating Data	6
3.3 Wiring	6
Section 4.0: Startup	
4.1 Inspection	7
4.2 Pre-Start Adjustments	7
4.3 Starting	8
Section 5.0: Troubleshooting	
5.1 Diagnostics	10
Section 6.0: Diagrams	
6.1 Electrical	12
6.2 Mechanical	12
Section 7.0: Operating Modes	
.....	13
Section 8.0: Wiring Diagrams	
8.1 Standard EZ6-40 Wiring Diagram	14
8.2 Standard EZ6-80 thru EZ6-125 Wiring Diagram	15
8.3 Standard EZ6-180 thru EZ6-500 Wiring Diagram	16
Section 9.0: Dimensional Outlines	
9.1 EZ6-40 thru EZ6-125	17
9.2 EZ6-180 thru EZ6-800	18
Section 10: Spare Parts	
.....	19
Section 11: EZ6 Options	
.....	20
Section 12: Warranty	
.....	21

1.0 DESCRIPTION

1.1 Overview The EZ6 is a Solid State Reduced Voltage Starter containing 6 SCR's (silicon controlled rectifiers), designed to control the current supplied to an induction motor. The SCR's are connected in 3 back to back pairs, phase controlled over 180 degrees of each cycle of power line frequency by a phase locked-loop digital firing circuit, containing a unique circuit which continuously synchronizes to any frequency variations and which requires no customer adjustment.

Since a motor's torque varies as the square of applied current, EZ6 starters can be programmed to provide a gradual build-up of torque from a low value up to almost full motor locked rotor torque, to provide gentle, jolt-free starting of any induction motor. In addition, to light load applications, such as pumps and fans, they can be programmed to limit peak starting currents to a constant low value, and so prevent excessive voltage drops during motor starting.

- 1.2 Standard Features**
- **Universal Source Matching**
The EZ6 starter automatically adjusts itself to whatever input voltage and frequency is applied, between 200 to 600 volts, and 45 to 65 Hertz, irrespective of phase rotation.
 - **Closed Loop Starting**
The EZ6 starts a motor in a continuous controlled current mode, eliminating any motor jerking or hunting that could be experienced in open loop types of reduced voltage starting.
 - **Built-in Motor Protection**
The EZ6 starter is manufactured with the following features:
 - Class 20 Electronic Motor Overload protection is supplied as standard on all models.
 - Single Phase Protection.
Instantaneous Overcurrent Trip. This unique feature minimizes the possibility of fuse blowing during starting if a line to line, or line to ground short is present in the starter, wiring, or motor.
 - **Shorted SCR Protection**
The EZ6 will detect a shorted SCR (or welded contact in the by-pass contactor, if used) and will prevent restarting the motor.

Enhanced motor protection may be provided by interlocking an inline contactor or circuit breaker shunt trip, with the starter fault contact to remove power in the event of shorted SCR detection.
 - **Multiple LED Diagnostics**
The following LED's are provided on the control card. LED on means a healthy condition, (See page 9).
 - 1) +12 VDC PRESENT
 - 2) THREE PHASE PRESENT
 - 3) No Shorted SCR
 - 4) Phase Locked Loop
 - 5) Motor Overload

Separate O/L protection is required for UL approval and is supplied on most models. See p.3.

1.2 Standard Features (cont'd)

- 6) Instantaneous Overcurrent
- 7) Ready
- 8) Run
- 9) Starter On

LED's 1 through 6 must be ON before the Ready LED illuminates. This indicates that the starter is healthy and OK to start. See Troubleshooting, pages 8 and 9 for LED details.

- **Dual Starting Mode**

Mode selection provides optimum performance to match the EZ6 starter to the motor's load characteristics, (See pages 8 and 13).

Constant Current.

In this mode, the current during starting is maintained at a value between 200% and 400% of the motor full load amperes (FLA) set by the customer. At full speed the current is determined by the motor load.

Step Ramp.

In this mode, the starter provides an initial current step adjustable between 200% and 400% of FLA, as above, and then increases it to 500% of FLA over a time period adjustable between 3 and 30 seconds. At full speed the motor current is determined by the load.

- **Dual Starter Rating**

Dual rating optimizes utilization of the starter according to the load.

Heavy Duty.

(Friction type loads or large inertias) Rated 500% FLA overload for 30 seconds, see table 1, page 3.

Light Duty.

(Medium to light inertia type loads) Rated 350% FLA overload for 30 seconds, see table 1, page 3.

Heavy duty is recommended for all friction type, constant torque, or high inertia loads. For moderate inertia or variable torque loads, the light duty rating can be used. The light duty continuous rating of the starter is 1.5 times the heavy duty continuous rating as listed in table 1. The short time (30 second) ampere rating is approximately the same for both duties.

- **EZ6 Set-up Procedure**

Quick and easy steps requiring no special equipment or electrical skills fully set-up the EZ6 starter (see page 7).

2.0 SPECIFICATIONS

- 2.1 Electrical**
- **Power**
Three phase, 200 to 600 volts, 45 to 65 Hertz.
 - **Control**
Single phase, 120 volts, 50/60 Hertz, 50 VA (control only, fans and contactors require additional VA). 230 volt control is available as an option.
 - **Operator Devices**
Start/Stop pushbuttons.
Jog pushbutton.
Fault interlock (or motor over-temperature switch).
 - **Output Contacts**
Dry contacts rated 5 amps, 220 volts.
Run, 1 NO (Not available if 3 wire control is used).
Fault, 1 NO/NC.
 - **EZ6 Starter Unit Overload Capability**
Heavy duty: 500% for 30 seconds, 1.15 service factor.
Light duty: 350% for 30 seconds, 1.00 service factor.
 - **Wiring Diagrams**
Refer to section 8.0 for wiring diagrams.
 - **Ratings**
Table 1

MODEL NUMBER	HEAVY DUTY 500% FOR 30 SECONDS					LIGHT DUTY 350% FOR 30 SECONDS				
	RATED AMPS	MAXIMUM HORSEPOWER				RATED AMPS	MAXIMUM HORSEPOWER			
		200V	230V	460V	575V		200V	230V	460V	575V
EZ6-40	40	10	15	30	40	60	15	20	40	50
EZ6-80	80	25	30	60	75	120	40	40	75	100
EZ6-125	125	40	50	100	125	188	60	60	150	150
EZ6-180	180	60	75	150	150	270	75	100	200	250
EZ6-240	240	75	100	200	250	360	125	150	300	300
EZ6-360	360	125	150	300	300	540	150	200	400	500
EZ6-500	500	150	200	400	500	750	250	300	500	500
EZ6-800	800	300	300	600	800	CONSULT FACTORY				

2.1 Electrical (cont'd)

- **Short Circuit Rating**

The EZ6 starter is suitable for use on a circuit capable of delivering not more than the listed rms symmetrical amperes, 600 volts maximum.

<u>Model</u>	<u>Amps</u>
EZ6-40	5,000
EZ6-80	
EZ6-125	10,000
EZ6-180	18,000
EZ6-240	18,000
EZ6-360	30,000
EZ6-500	30,000

2.2 Electrical Protection

- **Short Circuit Protection and Disconnect Capability**

Short circuit protection and disconnect means is provided by the user in the form of a circuit breaker or fused disconnect. Fuses should be either type J or RK1, capable of interrupting 200,000 amps, and should be sized according to all applicable codes. Enhanced short circuit protection may be added by using either a series contactor or a circuit breaker shunt trip, wired to remove power in the event of an an overload trip or starter fault.

- **Electronic Motor Overload**

Class 20, manual reset is standard. Class 10 or 30 are optional.

- **Electro-Mechanical Overload**

Class 10 standard on most models. Consult factory.

- **Single Phase Protection**

The EZ6 will not operate if a single phase condition is detected prior to starting. If the motor is running under full load when a single phase occurs, the EZ6 will trip.

- **Instantaneous Overcurrent**

If the instantaneous value of line current exceeds 900% FLA, the starter will shut down. The trip condition can be manually reset.

- **Shorted SCR**

The starter will not operate if an SCR is shorted (or contact is welded in the by-pass contactor). If an SCR fails while running, the starter will remain on until stop is commanded. The shorted SCR is then detected, and the fault relay tripped. Enhanced motor protection may be provided by interlocking an inline contactor or circuit breaker shunt trip, with the starter fault contact to remove power in the event of shorted SCR detection.

- **Surge Protection**

The starter is protected by high energy absorbing MOV's across each pair of SCR's.

- **Heatsink Overtemperature**

Thermal switches are provided to protect the heatsink assembly from overheating. If an overtemperature trip occurs, reset the internal electrical interlock by pressing the stop pushbuton. Once the temperature of the

2.2 Electrical Protection
(cont'd)

heatsink drops to an acceptable level the unit may be restarted. (See page 6).

- **Fault Relay**

The fault relay will operate if any of the following are detected:

Motor Overload (OL)

Instantaneous Overcurrent (IOC)

Shorted SCR

2.3 Mechanical For dimensional information see pages 17 and 18.

3.0 RECEIVING & INSTALLATION

3.1 Installation

The cabinet containing the EZ6 starter must be installed in an area where the following conditions exist:

Ambient temperature does not exceed 40°C (104°F).

Ambient temperature is not less than 10°C (50°F).

Altitude above sea level is 1000 meters (3300 feet) or less.

Ambient air is reasonably clean, dry and free of flammable or combustible vapors, steam, or corrosive gases.

The cabinet must be installed away from any heat source, and a minimum of 30 cm (1 foot) is required around the air inlet and outlet, on ventilated units.

The EZ6 starter has been designed for 50°C maximum inside the enclosure.

3.2 Derating Data

When the unit is installed in poor environmental conditions, it must be derated as follows:

1.5% per °C above 40°C, or 0.75% per °F above 104°F.

1% for every 100m above 1000m, or for every 300 feet above 3300 feet.

3.3 Wiring

The EZ6 starter is to be connected according to the NEC and any other applicable electrical codes in the customer's area.

The customer is responsible for providing adequate short circuit protection, (See page 3).

- Power Factor Capacitor Connection

CAUTION: Power factor correction capacitors, when utilized, must be connected to the line side of the starter, and never to the load side.

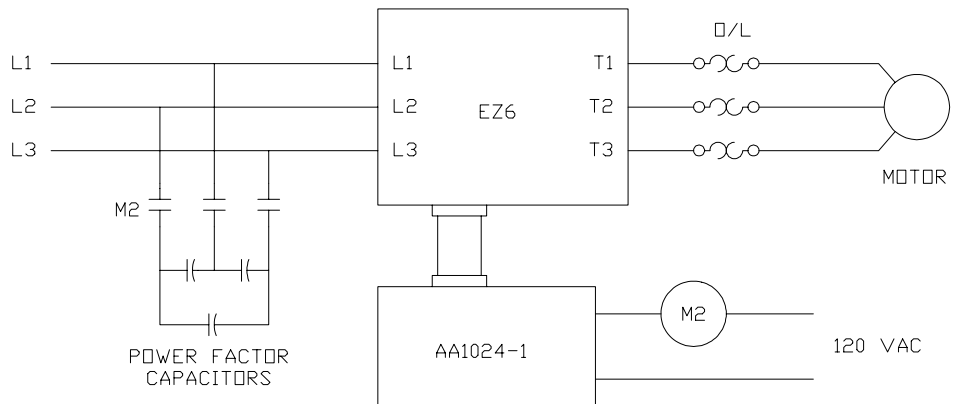

4.0 STARTUP

4.1 Inspection Ensure that the starter has been installed according to the previous guidelines. Also, ensure that the unit has been wired according to the schematics. Check that all connections are tight. Check that the motor can rotate freely.

Before power is applied to the starter the following settings should be made:

4.2 Pre-start adjustments
(See pages 6 and 7)

CAUTION: *Equipment is at lethal AC line voltage when AC power is connected. Pressing stop pushbutton does not remove AC line voltage. All phases must be disconnected before it is safe to touch motor terminals or control equipment parts.*

- **Starter Duty**
Select the proper duty, "heavy" or "light", by means of link P6 on the control card (see page 9). The link is located at the bottom right corner of the card. Heavy duty should always be selected, provided the ampere rating of the motor is within the ampere range of the starter, as shown on the High Voltage Card label (See page 9).
- **Starting Mode**
Select either "constant current" or "step ramp" starting mode as required by the application. This selection is made by link P7, located near link P6. Constant current is recommended for light and moderate inertial type loads. Current ramp is recommended for heavy inertia and friction type loads. Refer to page 2 for detailed selection criteria, and page 13 for typical curves.
- **Current Step**
The initial current step is adjustable between 200% and 400% of motor FLA.. In the constant current mode, the accelerating current during starting is maintained at the value set by this adjustment. In the step ramp mode, this adjustment sets the initial value from which the current begins to ramp to 500% FLA during acceleration. 100% FLA is the value set by SW1, on the high voltage card (See page 9). As an initial setting, the current step should be set at 300%, or approximately mid-position.
- **Ramp Time**
Ramp time, which operates only in the step-ramp mode, is adjustable from 3 to 30 seconds and sets the rate at which the current rises from its initial setting to its maximum or 500%. Initially, ramp time should be set at 15 seconds, or approximately mid-position.
- **Jog Voltage**
The jog function provides a low output voltage to run the motor at low speed. Jog voltage should be initially set at minimum, or full counter-clockwise.
- **Link Selection**
The EZ6 control card, page 8, has 7 programmable links. These links must be set as listed in table 2, page 6, except when option cards are used. In such cases, refer to the particular option card instruction sheet for proper link selection.
- **Motor FLA**
Set switch SW1 on the high voltage card, page 9, to the setting indicated on the current setting label, under the appropriate "heavy" or "" duty col-

CAUTION: *Excessive jogging will cause motor overheating!*

CAUTION: *Internal electronic overload can be disabled by selecting EXT O/L using link P2. Associated absence of an external overload, obviously means total lack of overload protection, which is not provided by back-up fuses or circuit breakers.*

4.2 Pre-start (cont'd)

umn. This setting must be done after, and only after, the starter duty has been selected.

• Table 2

LINK REFERENCE	LINK SET POSITION	LINK FUNCTION
P1	INT	PHASE ANGLE CONTROL
P2	INT	OVERLOAD
P3	FWD (LEFT)	FORWARD ONLY
P4	INT	I REFERENCE
P5	INT	L2 L3 INHIBIT
P6	SEE PAGE 7	STARTER DUTY
P7	SEE PAGE 7	STARTING MODE
360/1440	360	FREQUENCY

• Table 3

EZ6 STARTER STATUS		PHASE 1			PHASE 2			PHASE 3		
		1L DS1	1 ϕ DS2	1T DS3	2L DS4	2 ϕ DS5	2T DS6	3L DS7	3 ϕ DS8	3T DS9
OFF	READY TO RUN POWER & LOAD READY	OFF	ON	OFF	OFF	ON	OFF	OFF	ON	OFF
ON	NORMAL RUN MODE	ON	OFF	ON	ON	OFF	ON	ON	OFF	ON

4.3 Starting

A clamp-on ammeter is recommended to continuously monitor the motor current during the start-up procedure. A voltmeter across the starter output is desirable.

• **Power-Up**

Once the starter has been checked and set up, it is ready for power. Check that all personnel are clear of the starter and motor, then apply power. All LED's on the control card must be on except RUN and STARTER ON (See page 9). If they are not, see 5.0 Troubleshooting below.

• **Starting**

Press the "start" pushbutton and determine if the motor accelerates smoothly to full speed. If the motor does not accelerate, increase the current step setting to 400%, full CW, immediately. If the motor still fails to accelerate, press stop immediately and ensure that the motor is mechanically free to rotate. For a remotely located motor, it will be necessary to have another person stand by the motor, to communicate conditions during start-up. With the clamp-on ammeter, check that all three line currents are in balance.

• **Re-adjustment**

After the motor has been started, a fine adjustment might be required. It

CAUTION: Do not allow the motor to stall.

is good practice to set the starter to reach full speed in the minimum time permissible, without causing any appreciable power dip or excessive mechanical stress. The longest acceleration time is not necessarily the best setting because this may result in unnecessary motor rotor heating.

CAUTION: The motor must not be allowed to stall.

- Jog Setting**
 Set the jog voltage pot to minimum. Press and hold jog, then increase the jog voltage until the motor rotates. Release the jog button. The setting must be increased if there is a chance of having a heavier load than the one at start-up. Jog voltage must be adjusted to permit the motor to rotate under the heaviest load.

Control Card

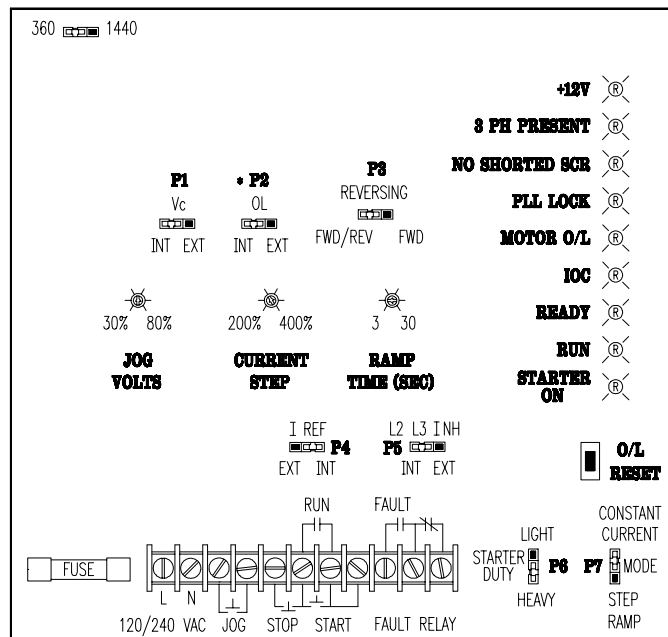

High Voltage Card

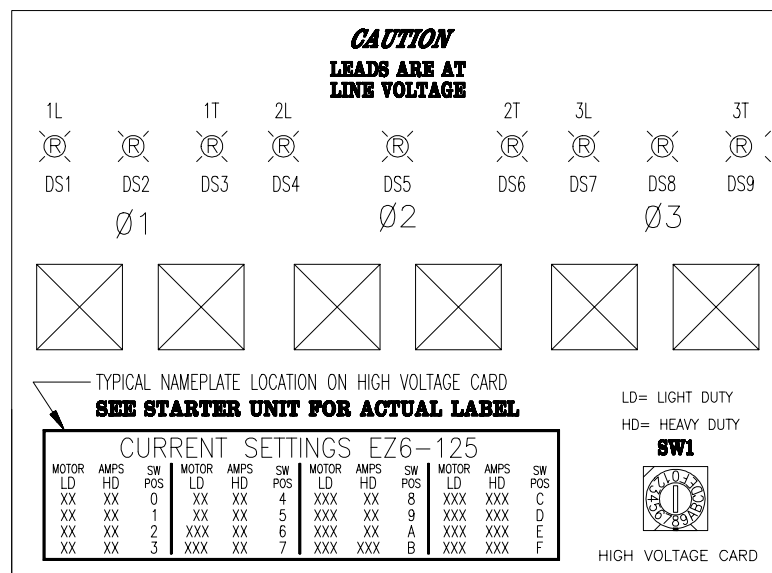

5.0 TROUBLESHOOTING

5.1 Diagnostics

The EZ6 has been designed with extensive LED indication for quick diagnostics. The control card contains the LED's listed below. They are visible from the front of the starter. In all cases, "LED ON" means a healthy condition. Also see page 9.

CAUTION: *Equipment is at lethal AC line voltage when AC power is connected. Pressing stop pushbutton does not remove AC line voltage. All phases must be disconnected before it is safe to touch motor terminals or control equipment parts.*

- **+12V LED**

This LED indicates the status of the internal +12 volt power supply. It is on when 120 VAC control voltage is present. All other LED's will be off if this LED is off. If this LED is off, check the 120 VAC supply across L-N on the control card terminal block (See page 9). If it is ok, check the fuse on the control card. If both are ok, then change the printed circuit board.

- **3 PH PRESENT LED**

This LED will be on when the three phase supply is present. If the LED is off, look at the LED's on the high voltage card to find out which AC line is missing (See page 9). LED's 1 (DS2), 2 (DS5), and 3 (DS8) are on when all SCR's are healthy and both line and load are present. The unit will not start if any of these LED's are off. The LED which is off indicates which AC line is missing, however, all three are off when the motor is running. A missing line will not trip the fault relay. Note: LED intensity may be low in the case of 208 or 230 VAC supplies.

- **NO SHORTED SCR LED**

This LED will turn on as soon as power is applied. If this LED is off, look at the high voltage card to find which SCR is shorted. The same LED's as discussed above, indicate which SCR pair is shorted, 1, 2, or 3. These LED's will also be off when the starter output is open. The output will be open if the motor is not connected or if an in-line contactor between the starter and motor is de-energized. A shorted SCR will cause the fault relay to trip, or, if present before starting, prevent the EZ6 from starting. LED's 1L (DS1), 1T (DS3), 2L (DS4), 2T (DS6), 3L (DS7), and 3T (DS9) are on when the scr gate circuits are functioning. If off, the starter is either not running or SCR's are not firing. Failure of SCR's to fire during running at full load will result in an overload trip.

- **NO MOTOR OVERLOAD LED**

This LED will turn on as soon as power is applied. The LED will be off when the electronic inverse time motor overload has tripped. The LED will remain off until manually reset using the pushbutton on the control card (See page 9). The fault can only be reset after a short time delay. A motor overload fault will cause the relay to trip.

- **PLL LOCK LED**

The LED will be on when three phase power is present. This LED indicates the status of the phase locked loop circuitry, which synchronizes the starter with the AC supply. If a PLL fault is present, the starter will not run, but will not cause the relay to trip.

CAUTION: *The electronic overload can be disabled by selecting EXT O/L on link P2 (see page 9). The O/L LED could be off, when an external overload is used, but it will have no effect on starter operation.*

- **IOC LED**
The IOC (instantaneous overcurrent) LED must be on when control voltage is present. If an IOC fault occurs, the LED will stay off until the O/L reset pushbutton on the control board is reset. If an IOC fault is indicated before starting, check the CT connections on the high voltage card, and ensure that the connector to the CT's id securely plugged in. If this fault occurs after the start command, look for a short circuit across the starter output terminals. This fault will trip the fault relay (see page 9).
- **READY LED**
This LED will be on when (1) all the above LED's are ok, (2) any option cards used are fault free, and (3) the heatsink O/T switch is closed (normal).
- **RUN LED**
This LED will be on when the starter is in the run condition.
- **STARTER ON LED**
This LED will be on when the starter is in either the run or jog mode.

6.0 DIAGRAMS

- 6.1 Electrical** Typical wiring diagrams are shown on pages 14 through 16 which are described as follows:
- EZ6-40 Starter, see page 14.
 - EZ6-80 through EZ6-125 Starters, see page 15.
 - EZ6-180 through EZ6-500 Starters, see page 16.
- 6.2 Mechanical** Dimensional outlines are shown on pages 16 and 17. All drawings apply to the basic starter units. Even though no dimensional changes occur, in many cases, where option cards are added, consult the factory for specific information.

7.0 OPERATING MODES

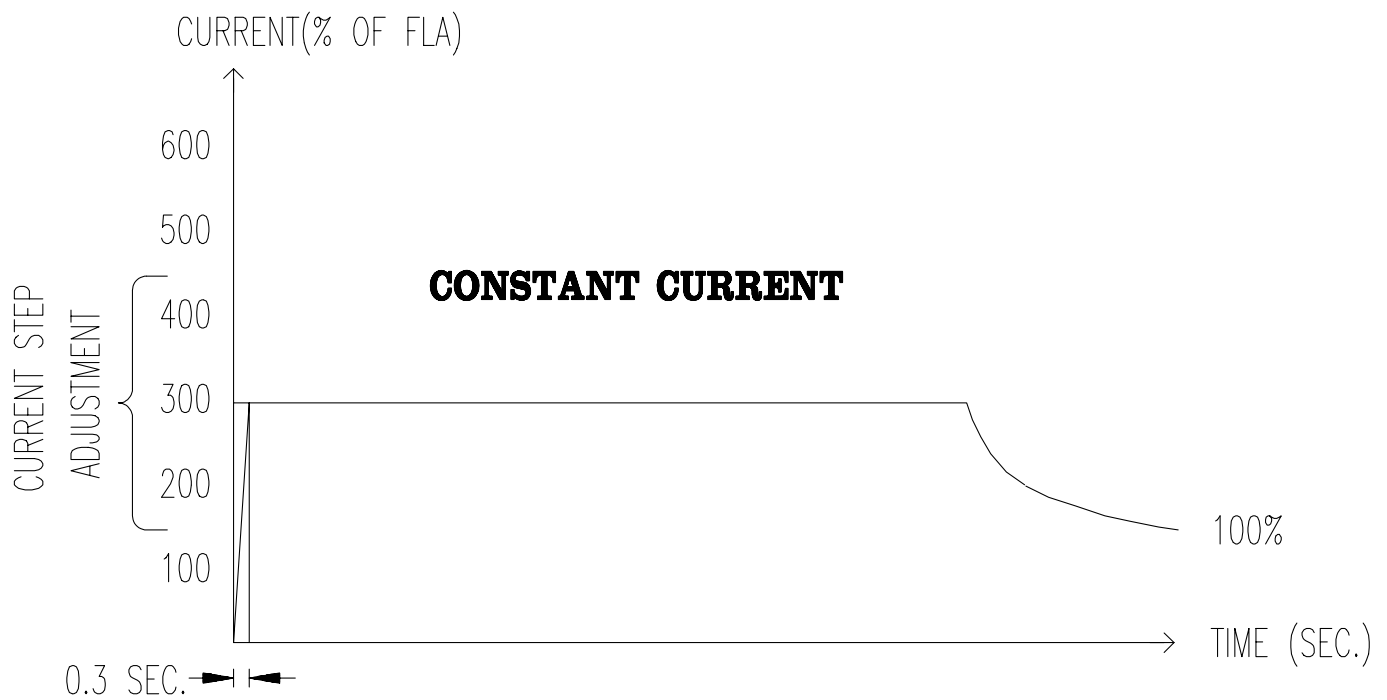
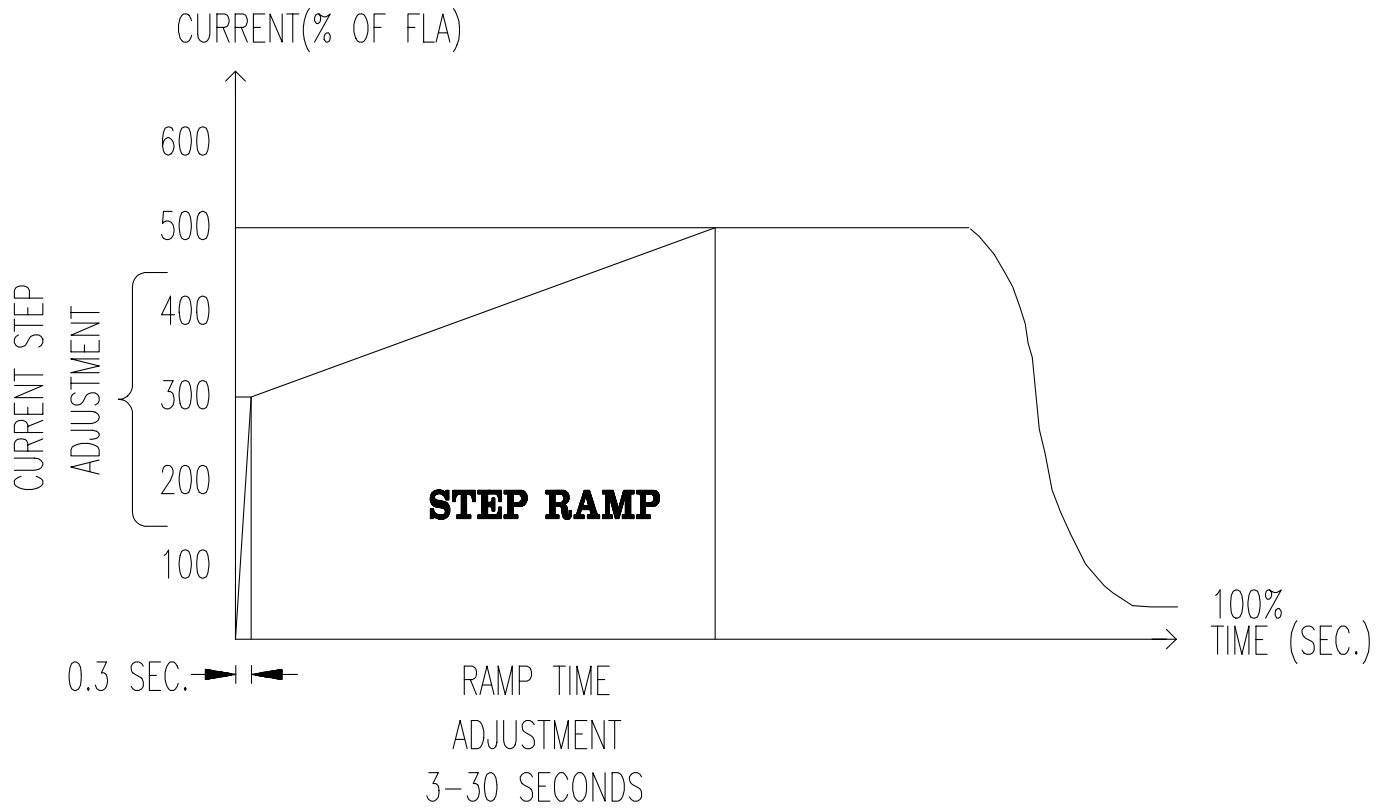

8.0 WIRING DIAGRAMS

8.1 EZ6-40 Wiring Diagram

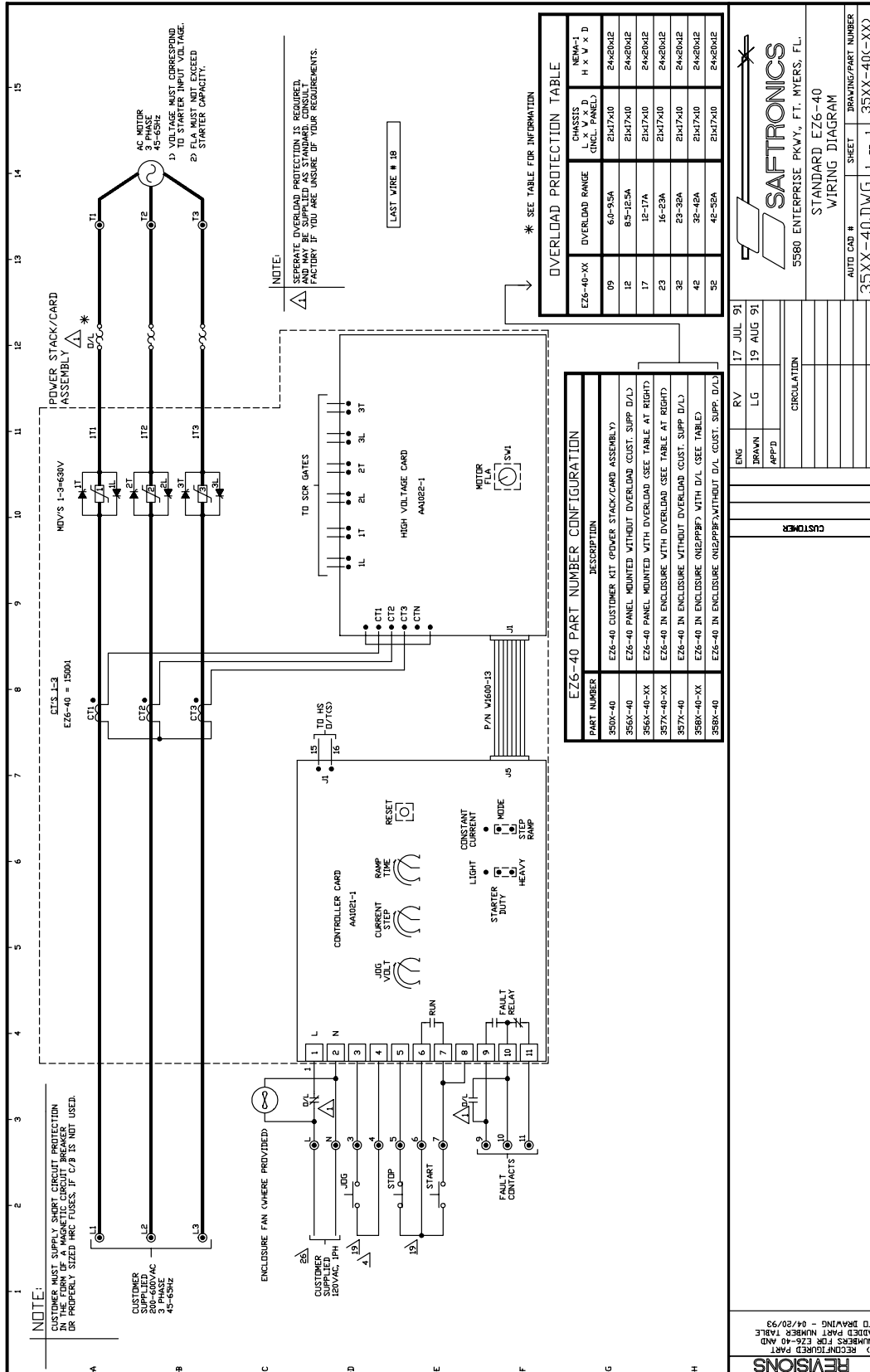

8.0 WIRING DIAGRAMS (CONT'D)

8.2 EZ6-80 thru EZ6-125 Wiring Diagram

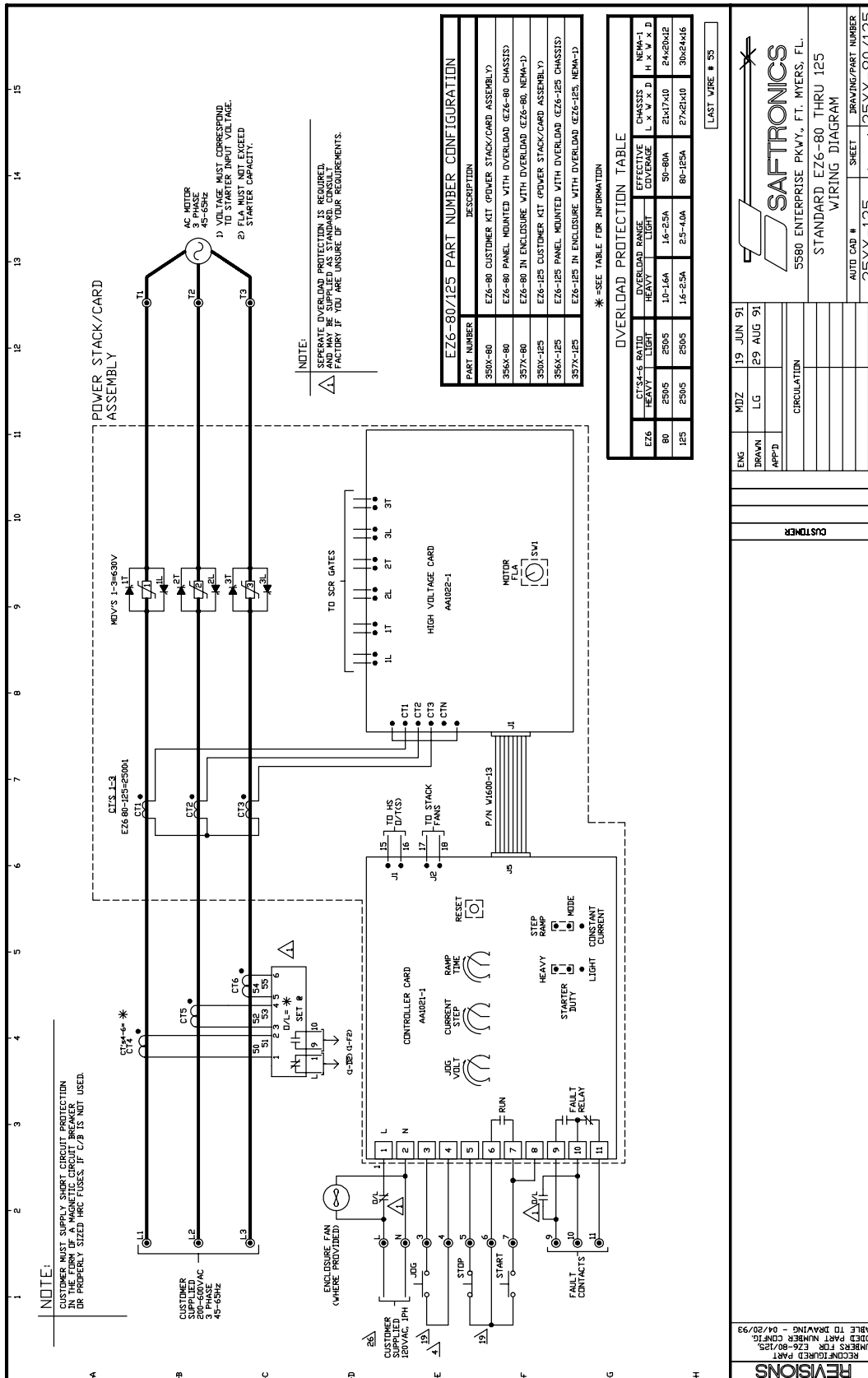

8.0 WIRING DIAGRAMS (CONT'D)

8.3 EZ6-180 thru EZ6-500 Wiring Diagram

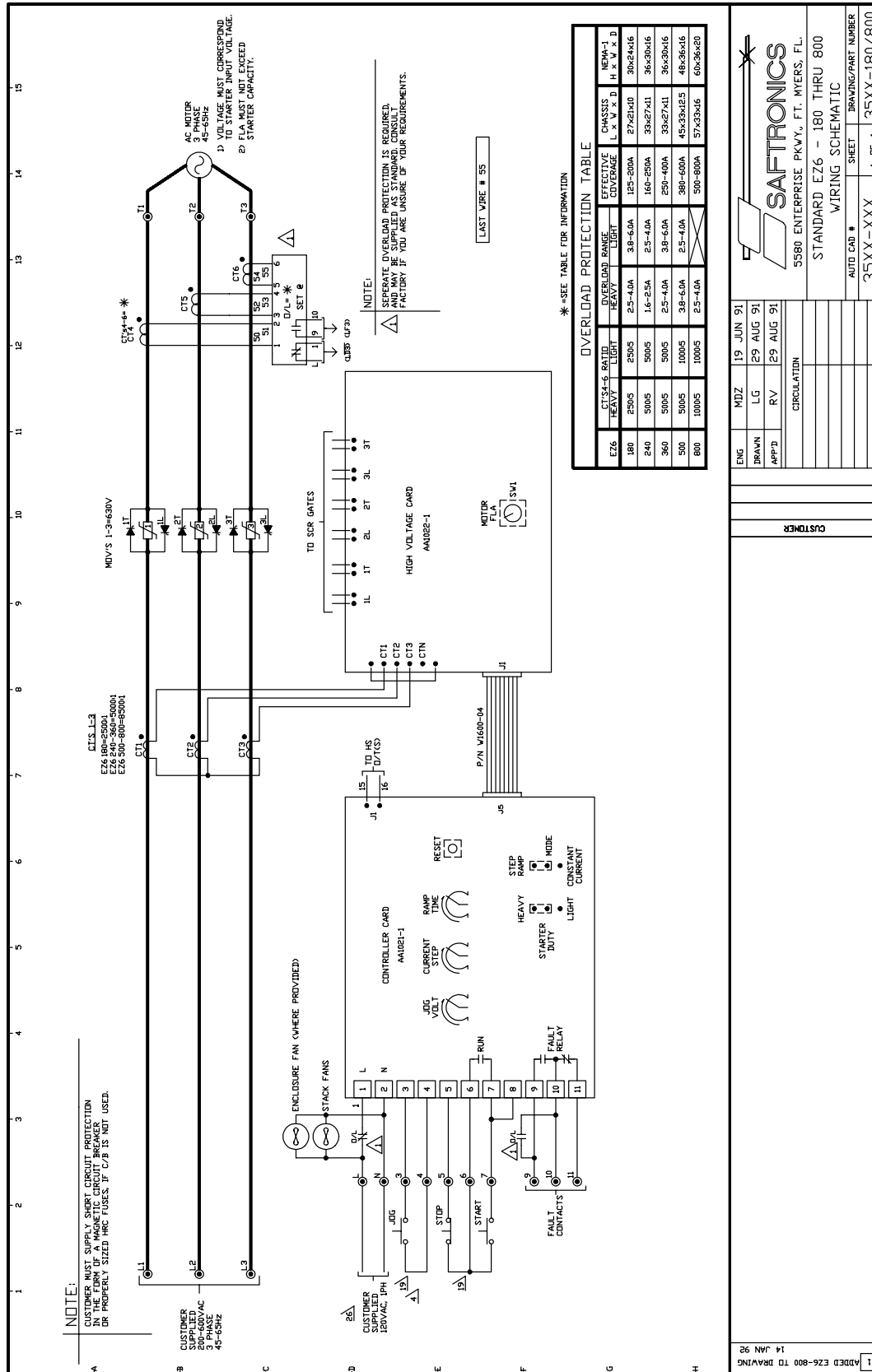

5580 ENTERPRISE PKVY., FT. MYERS, FL.
STANDARD EZ6 - 180 THRU 800
WIRING SCHEMATIC

ENG	MDZ	19 JUN 91
DRAWN	LG	29 AUG 91
APP'D	RV	29 AUG 91
CIRCULATION		
CUSTOMER		
DRAWING/PART NUMBER		
35XX-XXX		
SHEET		
1 OF 1		

1 ADDED EZ6-800 TO DRAWING 14 JAN 92

9.0 DIMENSIONAL OUTLINES (CONT'D)

9.2 EZ6-180 thru EZ6-800 Outline

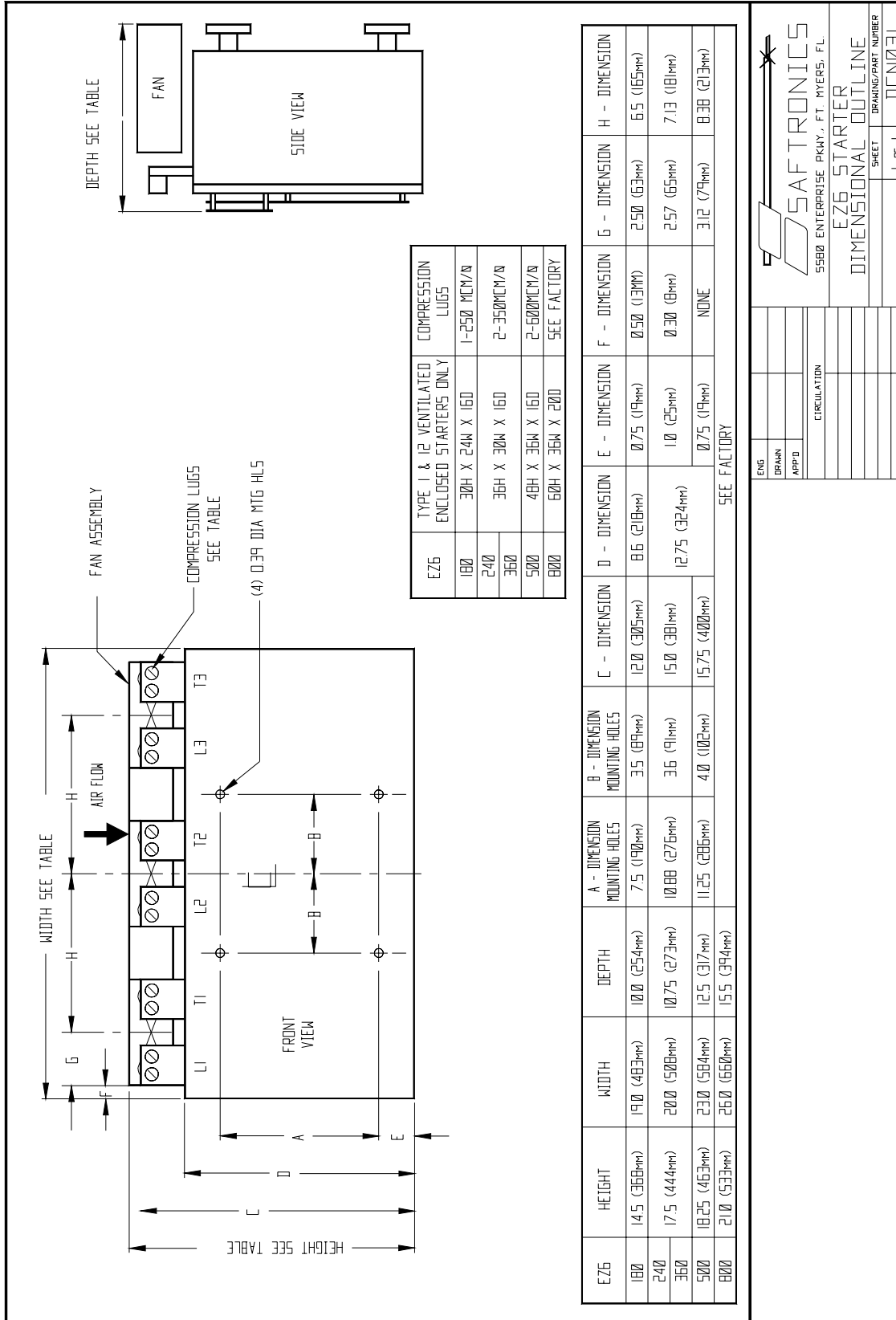

10.0 SPARE PARTS

SERIES	PART NO.	DESCRIPTION	QTY USED	QTY SPARES
PC BOARDS				
EZ6-40	A1AA1022A	HIGH VOLTAGE CARD	1	1
EZ6-80	A1AA1022B			
EZ6-125	A1AA1022C			
EZ6-180	A1AA1022D			
EZ6-240	A1AA1022E			
EZ6-360	A1AA1022F			
EZ6-500	A1AA1022G			
EZ6-800	A1AA1022H			
EZ6-40, 80, 125	A1AA1021B	CONTROL CARD	1	1
EZ6-180, 240, 360, 500, 800	A1AA1021T			
SCR'S 1600V				
EZ6-40	N10SP06A	DUAL SCR 90A	3	3
EZ6-80	N20SP10	DUAL SCR 142A		
EZ6-125	N20SP08	DUAL SCR 250A		
EZ6-180	N728452	SCR 680A	6	
EZ6-240	N716452	SCR 820A		
EZ6-360, 500, 800	N719122	SCR 1400A		
CURRENT TRANSFORMERS				
EZ6-40	T5004-01	1500:1	3	1
EZ6-80, 125, 180	T5003-02	2500:1		
EZ6-240, 360	T5003-03	5000:1		
EZ6-500, 800	T5003-04	8500:1		
MISCELLANEOUS				
EZ6-40, 80, 125	W1600-13	RIBBON CABLE	1	1
EZ6-180, 240, 360, 500, 800	W1600-04	RIBBON CABLE		
ALL EXCEPT EZ6-40	S523002-03	TEMPERATURE SWITCH	1	1

SAFTRONICS

11.0 EZ6 OPTIONS

SERIES	PART NO.	DESCRIPTION	QTY	COMMENTS
BYPASS				
EZ6-40 THRU EZ6-125	AP01-12	BYPASS CARD	1	CONNECT PER PRINT. SIZE BYPASS CONTACTOR FOR AC1 DUTY.
	W2600-08	RIBBON CABLE		
	W5018	6 PIN PLUG ASS'Y		
	V2020-03	SPACERS	4	
EZ6-180 THRU EZ6-800	AP01-12	BYPASS CARD	1	
	W2600-08	RIBBON CABLE		
	W50018	6 PIN PLUG ASS'Y		
	V2020-07	SPACERS	4	
SHEARPIN TRIP				
EZ6-40 THRU EZ6-125	AP01-05	SHEARPIN CARD	4	CONNECT PER PRINT. SHORT P1, P2 TO EXT ON AA1021.
	W2600-08	RIBBON CABLE		
	V2020-03	SPACERS		
EZ6-180 THRU EZ6-800	AP01-05	SHEARPIN CARD	4	
	W2600-08	RIBBON CABLE		
	V2020-07	SPACERS		
ENERGY SAVER				
EZ6-40 THRU EZ6-125	AP01-14	ENERGY SAVER CARD	1	
	W2600-08	RIBBON CABLE	4	
	V2020-03	SPACERS		
EZ6-180 THRU EZ6-800	AP01-14	ENERGY SAVER CARD	1	
	W2600-08	RIBBON CABLE	4	
	V2020-07	SPACERS		

12.0 WARRANTY

Saftronics warrants to buyer that products, and any services furnished hereunder will be free from defects in material, workmanship and title, and will be of the kind and quality specified in the quotation. The foregoing shall apply only to failures to meet said warranties (excluding any defects in title) which appear within one year from the date of shipment hereunder; provided, however, that if buyer, in the course of its regular and usual business, transfers title to or leases such products (including equipment incorporating such products) to a third party, such period shall run until one year from such transfer or lease or eighteen months from shipment by Saftronics whichever occurs first. The warranties and remedies set forth herein are conditioned upon (a) proper storage, installation, use and maintenance, and conformance with any applicable recommendations of Saftronics and, (b) buyer promptly notifying Saftronics of any defects and, if required, promptly making the product available for correction.

If any products or services fails to meet the foregoing warranties (except title), Saftronics shall thereupon correct any such failure either, at its option, (i) by repairing any defective or damaged part or parts of the products, or (ii) by making available FOB Saftronics plant or other point of shipment, any necessary repaired or replacement parts. The preceding paragraph sets forth the exclusive remedies for claims (except as to title) based on defect in or failure of products or services, whether claim in contract or tort (including negligence) and however instituted. Upon expiration of the warranty period, all such liability shall terminate. The foregoing warranties are exclusive and in lieu of all other warranties, whether written, oral, implied or statutory. No implied statutory warranty of merchantability or fitness for particular purpose shall apply and Saftronics will not be liable for any consequential damage arising from any product defect or failure to deliver on time. Saftronics does not warrant any products or services of others which buyer has designated.